

FINE & RARE WINES AND SPIRITS
FEATURING AN EXCEPTIONAL PRIVATE COLLECTION
AND A COLLECTION OF CENTURY OLD MADEIRA

佳士得珍罕名釀及烈酒：
呈獻顯赫私人珍藏及馬德拉酒百年極尚窖藏

Hong Kong 23 November 2019 | 香港 2019 年 11 月 23 日

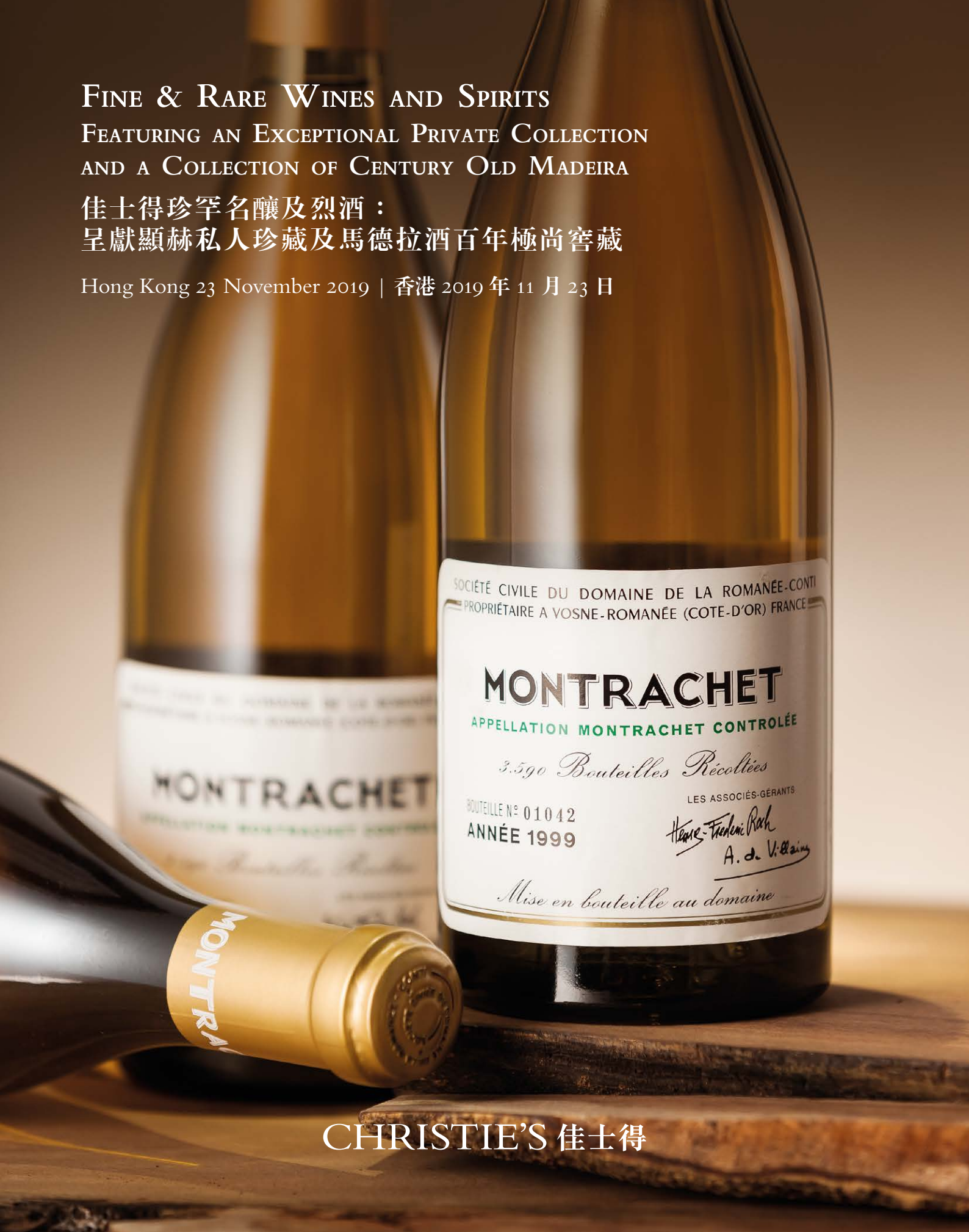

CHRISTIE'S 佳士得

INTERNATIONAL WINE DEPARTMENT & AUCTION CALENDAR

GLOBAL MANAGING DIRECTOR, LUXURY

Aline Sylla-Walbaum
Tel: +44 (0)20 7389 2554

HEAD OF DEPARTMENT/ HEAD OF SALE

CONTINENTAL EUROPE

Edwin Vos
Tel: +31(0)20 575 5208

LONDON

Noah May
Tel: +44 (0)20 7752 3140

NEW YORK

Chris Munro
Tel: +1 212 641 7518

SENIOR CONSULTANT

Michael Broadbent M.W.
Tel: +44 (0)20 7752 3302

CONSULTANT

Carolyn Holmes
Tel: +44 (0)20 7752 3302

WORLDWIDE

AMSTERDAM

Edwin Vos
Tel: +31 (0)20 575 5208

BEIJING

Geoffrey Liu (Liaison)
Tel: +86 10 8572 7924

GENEVA

Edwin Vos
Agathe de Saint Céran
Tel: +41 (0)22 319 1760

HONG KONG

Fai Lo
Ned Zhang
Tiffany Po
Tel: +852 2978 6761

LONDON

Noah May
Tim Triptree M.W.
Charles Foley
Tel: +44 (0)20 7752 3302

LOS ANGELES

Chris Munro
Tel: +1 310 385 2625

NEW YORK

Chris Munro
Peter Rusinak
Macy Pigman
Tel: +1 212 636 2270

PARIS

Edwin Vos
Agathe de Saint Céran
Tel: + 33 (0)1 40 76 83 68

BUSINESS MANAGERS

FRANCE / GENEVA

Virginie Aubert
Tel: +33 (0)1 40 76 85 93

HONG KONG

Isabel Coutier
(Regional Managing Director)
Tel: +852 2978 9940

LONDON

Virginie Dulucq
Tel: +44 (0)20 7389 2853
Evi Devriese
(Head of Sale Management)
Tel: +44 (0)20 7104 5701

NEW YORK

Devon Elovitz
(Head of Sale Management)
Tel: +1 212 641 5776

23/10/19

AUCTION CALENDAR 2019

To include your property in these sales please consign ten weeks before the sale date. Contact the specialists or representative office for further information.

22 OCTOBER-5 NOVEMBER WINE ONLINE/NY ONLINE

10 NOVEMBER
FINEST & RAREST WINES:
THE 40 YEARS JUBILEE OF
ALPINA FINE WINES
GENEVA

11 NOVEMBER
FINE AND RARE WINES
FEATURING A FORGOTTEN
SWISS PRIVATE CELLAR
GENEVA

17 NOVEMBER
159EME VENTE DES VINS
DES HOSPICES DE BEAUNE
PARIS

23 NOVEMBER
FINE & RARE WINES AND
SPIRITS FEATURING AN
EXCEPTIONAL PRIVATE
COLLECTION AND A
COLLECTION OF CENTURY
OLD MADEIRA
HONG KONG

28-29 NOVEMBER
FINE & RARE WINES &
SPIRITS
LONDON

13 DECEMBER
FINE & RARE WINES
NEW YORK

Subject to change.

23/10/19

SERVICES · 服務

WRITTEN AND TELEPHONE BIDS & CHRISTIE'S LIVE

書面和電話競投及佳士得實時競投服務

Tel 電話：+852 2978 9910

Email 電郵：bidsasia@christies.com

PADDLE REGISTRATION 競投牌登記

Tel 電話：+852 2760 1766

Email 電郵：registrationasia@christies.com

CATALOGUES ONLINE 網上拍賣目錄

Lotfinder®

Internet 網站：www.christies.com

CLIENT SERVICES 客戶服務

Tel 電話：+852 2760 1766

Email 電郵：infoasia@christies.com

POST-SALE SERVICES 售後服務

Tel 電話：+852 2760 1766

Email 電郵：postsaleasia@christies.com

ENQUIRIES · 查詢

HK 香港：+852 2760 1766

UK 英國：+44 (0)20 7627 2707

US 美國：+1 212 703 8080

Internet 網站：www.christies.com

Effective February 1, 2019, the buyer's premium charge of Christie's Hong Kong Wine auctions is 25% of hammer price.

自2019年2月1日起，香港佳士得名酒拍賣買家應付之酬金為下槌價的25%。

FINE & RARE WINES AND SPIRITS

FEATURING AN EXCEPTIONAL PRIVATE COLLECTION AND A COLLECTION OF CENTURY OLD MADEIRA

佳士得珍罕名釀及烈酒：
呈獻顯赫私人珍藏及馬德拉酒百年極尚窖藏

SATURDAY 23 NOVEMBER 2019 · 2019年11月23日(星期六)

AUCTION · 拍賣

Saturday 23 November · 11月23日(星期六)

10.30am (Lots 5001-5839) · 上午10.30 (拍賣品編號5001-5839)

Location: Grand Hall, Hong Kong Convention and Exhibition Centre,
No.1 Expo Drive, Wanchai, Hong Kong

地點：香港灣仔博覽道1號香港會議展覽中心大會堂

Tel 電話：+852 2760 1766 · Fax 傳真：+852 2760 1767

AUCTION CODE AND NUMBER · 拍賣名稱及編號

In sending Written and Telephone bids or making enquiries, this sale should be referred to as **DAVID-17625**

在遞交書面和電話競投表格或查詢拍賣詳情時，請註明拍賣名稱及編號為 **DAVID-17625**。

CONDITIONS OF SALE · BUYING AT CHRISTIE'S

業務規定 · 買家須知

This auction is subject to Important Notices and Explanation of Cataloguing Practice, Conditions of Sale · Buying at Christie's and reserves of the lots.

此次拍賣受限於重要通知及目錄編列方法之說明、業務規定、買方須知及拍品底價。

REGIONAL MANAGING DIRECTOR · 業務總監

Isabel Coutier

Tel 電話：+852 2978 9940

SALE CO-ORDINATOR · 拍賣統籌

Jennifer Lo 盧正琛

Tel 電話：+852 2978 6761

EMAIL · 電郵

For general enquiries about this auction, emails should be addressed to the Sale Co-ordinator(s) at wineauction@christies.com

如對此拍賣有任何查詢，可與佳士得拍賣統籌聯絡。

電郵地址：wineauction@christies.com

AUCTIONEERS · 拍賣官

Edwin Vos

Georgina Hilton

Fung Chiang

Max Fawcett

CHRISTIE'S 佳士得

CHRISTIE'S LIVE
Bid live in Christie's salerooms worldwide

christies.com

INTERNATIONAL WINE DEPARTMENT

ASIA TEAM



Fai Lo



Ned Zhang



Tiffany Po

SENIOR INTERNATIONAL TEAM



Chris Munro



Edwin Vos



Tim Triptree M.W.



Noah May

INTERNATIONAL CONSULTANT



Michael Broadbent M.W.

FINE & RARE WINES AND SPIRITS

FEATURING AN EXCEPTIONAL PRIVATE
COLLECTION AND A COLLECTION OF CENTURY
OLD MADEIRA

佳士得珍罕名釀及烈酒：
呈獻顯赫私人珍藏及馬德拉酒百年極尚窖藏

SATURDAY 23 NOVEMBER 2019

10.30am

Lots 5001-5839

Sale 17625

11月23日（星期六）

上午10時半

（拍品5001至5839）

編號17625

Location: Grand Hall, Hong Kong Convention and Exhibition Centre,
No.1 Expo Drive, Wanchai, Hong Kong
香港灣仔博覽道1號香港會議展覽中心大會堂

Please note that parcel bidding will be offered throughout Sale 17625.

請注意，本場拍賣（編號17625）部份拍品將以組合形式推出。成功投得每個組合第一款拍品的買家，可選擇以同一價格購買餘下所有或部份拍品。



David Elswood (1958-2019)

It is with great sadness that we must announce the passing of our longstanding and much admired colleague, David Elswood. David joined Christie's Wine Department in 1985, going on to become one of our finest auctioneers and later, our leader as International Head of Wine Sales at Christie's from 2003-2017.

David was an exceptional man in all respects. He was an inspiring leader, great friend and a beloved member of, and ambassador for, the fine wine community. We feel he will be missed enormously by those who knew him and worked with him over the years.

We would like to honour David's memory and legacy in our upcoming end-of-season auction catalogues in Geneva, Hong Kong, London and New York with a tribute page, including short comments from a group of leading figures in the international fine wine community. We hope that this collection of tributes goes some way to honour a great man.

Christie's International Wine Department

"I knew him very well and he was a very nice fellow. Very professional and I was proud to have him in the Wine Department and count him as a thoroughly dependable person. The department strove for excellence and he was at the heart of our endeavours."

Michael Broadbent MW

"My colleague, Aline Sylla-Walbaum, has related the news to me, and I cannot tell you how shocked, sad and sorry I am. David was loved by those who were close to him, admired by those who knew of him, and respected by those who work with him. He is taken from us far too soon, and will be sorely missed."

Jussi Pylkkänen, Global President, Christie's

"David was an inspiring personality for the Ornellaia and Masseto team over the years. He was greatly appreciated not only for his knowledge and professionalism, but also for his encouragement, humour and generosity. A real gentleman. He will be missed."

Giovanni Geddes da Filicaja, CEO Ornellaia & Masseto

"I first met David at a pre-sale tasting in London over 20 years ago, at a time when wine was less of a luxurious product and more of an affordable hobby. As a young novice in this field, I had the pleasure to be guided by the professional team at Christie's. David's knowledge and passion for wine combined with his wise and light-hearted comments made him a great companion with whom I have shared many splendid bottles. He will be missed as a friend as well as an accomplished auctioneer."

Paulo Pong, Managing Director, Altaya Group

"David was always ready with a quip, a kind word & a sparkle in his eye. The world will be poorer without him"

Don Weaver, Director, Harlan Estate

"I was extremely sorry to hear the very sad news regarding the passing of David Elswood. I would like to express my most sincere condolences to his family. I will keep a very good memory of a passionate wine lover. He was a great ambassador of our wines. It is a great sadness that he died so young..."

Philippe Dhalluin, Managing Director, Executive Director Châteaux Wines

"That has taken the wind out of my sail on hearing such bad news of David's passing. Please convey my deepest sympathy on behalf of Jason and myself to his family."

"When I decided to put my collection of wine up for sale there were a couple of options and until I met David it was difficult to choose but his approach so impressed me that it became an easy decision to put it in David's capable hands. The preparation of the catalogue and of selling it in Hong Kong and also the timing of the sale were all David's ideas, all I had to do was sit back and let him get on with it - great decision! God Bless David RIP."

Sir Alex Ferguson, CBE

"I am very sorry to hear the news of David's passing. I never had the opportunity of working closely with him, but we grew up in the wine trade pretty much at the same time and I always hugely enjoyed interaction with David from time to time over the years and very much appreciated his qualities. Even more so once I began my Christie's role. David was one of the very special people and I am sure you and all his former colleagues will be missing him very much."

Jasper Morris MW

"David and I coincided at Christie's wine department over fifteen years, and it was a constant pleasure. He managed a big team of young people with great skill. He was masterly at looking after the interests of clients at both ends of the auction process - consignors, for whom his charm, wine knowledge and enthusiasm could be irresistible, and those in front of the rostrum, who knew he would be speedy, fair and impeccably attentive. He was a perceptive wine taster, with a great memory, and such a vibrant person, so full of life - not bookish but living in the moment. He handled his illness with real grace. As an auctioneer he was extraordinary, with a rare ability to engage with people, his wit and repartee never failing him. He is sadly and greatly missed."

Anthony Hanson, MW

"I was very sad to hear this news and our thoughts are with David's family and all those at Christies. Please pass on my deepest condolences to his family."

Chris Blandy, CEO Madeira Wine Company

"We were very sad to hear about the untimely death of David and we and the entire wine business will miss him greatly. During his years at Christie's, his knowledge, his great tasting ability, his skill with the gavel at the podium, brought him many friends and admirers. His sense of fun, his sheer enjoyment of the wine business and his refreshing, off the cuff observations were wonderful. Happy memories."

Jacques & Fiona Thienpont, Le Pin

"I just can't quite comprehend that we won't be seeing David again. He will be sorely missed. He was such an integral part of Christie's, such a natural with the hammer, such a talented organiser and just such fun to be around with. My thoughts and heartfelt condolences go out to his family."

Bill Blatch, Christie's Bordeaux

"This is very sad news for all the wine trade. David has left to all of us the image of a fantastic, dynamic and enthusiastic person. I am sending his family and friends my sincere condolences."

Hervé Berland, Château Montrose

"David's exceptional knowledge, professionalism and passion was only surpassed by his charm, sincerity and kindness. David was one of the wine trades greatest ambassadors and an inspirational figure in every respect."

Johnny Symington, Chairman of Symington Family Estates

"I was deeply saddened to learn of the very sad - and desperately premature - death of David. We joined Christie's only a year apart, in 1984 and 1985, worked together for some 14 years, and remained good friends. David was an exceptionally talented specialist - an excellent taster and an outstanding auctioneer. One of that extremely rare breed who are able to combine technical excellence with enormous flair and, above all, humour. His intermittent and very funny asides during the most serious of wine auctions were legendary and it was this flair and humour that saw him carve out a long-standing niche as a much-sought-after charity auctioneer. His dry humour and cheeky smile will be greatly missed."

Paul Bowker, Wilkinson Vintners



"I have been particularly touched to learn the death of David. For me he was a great man in the wine world. The Châteaux of Bordeaux and Cos d'Estournel in particular owe him a lot. He has been a great ambassador, for Bordeaux wines and for the reputation of Christie's. All the team of Cos is in mourning"

Michel Reybier, Château Cos d'Estournel

"I had a few hundred lunches and dinners with David over the 20+ years that I have known him. A couple of years ago, I had a small trade garden party at my house where we drank 1947 Lafleur along with many other great wines, the glasses were starting to get a bit low, so I sent David to the cellar to find us another bottle, he came back with 1988 Echezeaux Henri Jaye and said he had never tried this vintage, but I know he left me a very happy man that day.

RIP David, a great friend, gone but never forgotten."

Ronnie Cutmore, Bordeaux Vintners Ltd.

"David Elswood was both a very great friend of mine and a tremendous auctioneer.

His foresight, his flair, and his tremendous persuasion, backed by his peripheral vision of the world wide wine market was entirely responsible for the inaugural Christie's wine sale in Hong Kong which without doubt launched a thousand sales and was instrumental of starting the biggest and most legendary bull market in fine wine the world has ever seen.

His professionalism, coupled with a wry sense of humour was also instrumental in the success of the annual Hospices de Beaune auction and so many other Charity auctions; he will be severely missed by everyone as he never said no – he had a huge capacity for raising money for goodness

On a personal note David was an excellent taster and we both hosted and attended many, many wine lunches and dinners together; but may I share one with you.

I organised a blind bottle tasting for 12 people which took place in our garden in Hampshire in the UK one summers day.

We opened 35 bottles which all turned out to be vintage port from 1924 & 1927 & 1935 vintages – quite a haul for one afternoon !

Having tasted every vintage / bottle I was feeling somewhat part worn – but not David, ever the professional he said to me "sorry to rush off Piers, but my car is out front" I'm on the night flight to South Africa to do a charity Auction tomorrow

Bravo David "Carpe Diem"

Piers Methuen, Elliston Fine Wine

"David was a brilliant colleague and a true friend of mine for many years. When it came to the merits of wine enjoyment, he possessed that rare quality of embracing both the noble and the everyday. He was more than happy to drink the vino della casa in a Tuscan trattoria and pronounce it "lovely indeed", sometimes followed by a superb acapella rendition of That's Amore!. He had no need to uncork a superstar bottle to have a fine wine experience.

His boundless enthusiasm infused every second of his journey.

He was a remarkable man ."

Judy Beardsall, Wine Consultant

"We were told off by the conductor on a train from Dijon to Paris for making too much noise, and I said "he's only talking normally". A natural-born auctioneer, David had a voice that didn't need to be raised to be heard. If you arrived to a crowded hall you knew he was in it long before you caught sight of him. His was an enthusiasm for wine and for living the moment that would hold your attention, always leave your metaphorical tyres pumped up, your glass filled, and at some point your eyes streaming with tears from laughing too hard.

From 2004 we put together many wine dinners that have become some of my most cherished experiences. That he indulged me, as a then relative newcomer, in what became co-branded and co-hosted events, spoke to his generosity and openness. He was a collaborator, my mentor, and a dear friend that I dearly miss. Here's to you David – cheers! "

Linden Wilkie, The Fine Wine Experience

"I first met David Elswood to prepare and auction held in Hong-Kong in September 2016 under Christie's hammer, where a series of old vintages of Bouchard Père & Fils were offered to passionate collectors. This unique sale consisted in offering a glimpse into the 160 vintages constitutive of Bouchard Père & Fils, a collection in every way exceptional.

When David Elswood and Edwin Vos came at the Château de Beaune, one beautiful day in January, 2016, the meeting was natural, elegant and truly delectable. It actually turned into a rich and rejoicing discussion of cultivation where the passion for great wines was finally the pretext to sharing a passion for culture and human relationship.

I will always keep of David the memory of a real gentleman. A person of great culture and extreme courtesy. The sparkle of his eyes said his passion for fine wines as much as for the human adventure of which they are the achievement. His deep knowledge of wine and terroirs as well as of the historic and human aspects which underlie every of the legendary domains were offering a lively and fascinating open book on the world of fine wines.

David Elswood epitomized a brilliant celebration of all that French culture holds dear and which is expressed so marvellously in Burgundy: art de vivre, or the cult of friendship celebrated by the sharing of this divine beverage, which magically brings together the hearts and spirits.

Adieu donc cher David, I keep preciously the memory of your look: it was full of spirit and kindness."

Gilles de Larouzière, President Henriot

"For me, David embodied the true spirit of what you can expect from an English wine expert, i.e. a great and subtle knowledge of the world of wine, without being pretentious and obsequious, and this with that little and incomparable touch of British humour which makes us, French people, always so terribly envious! I enjoy reminiscing about his fine judgment, his expertise about the de Vogüé wines, as well as his cheerful disposition to enjoy good wine and good food as we do in Burgundy". I will miss David quite a lot"

Jean Luc Pepin, Estate Manager Domaine Comte Georges de Vogüé

"I was lucky enough to work together with David at Christie's in the late 90s. It never felt like work being in David's company. He had an enormous capacity for fun and a fantastic and infectious sense of humour. We laughed a lot but David was a serious professional with great experience and knowledge which he was happy to share generously. A superb auctioneer with a clear and commanding voice, speed and precision, his skills in the rostrum were to be admired. And David loved to be on the 'coal face' packing up private cellars all over Europe and discussing the wines as they were inspected, catalogued and packed into boxes in the depths of subterranean cellars. Nor did the fun end there. David was a great bon viveur always up for a good meal and a bottle of something special. He would hold court at The Memphis Hotel where we always stayed over during the Amsterdam wine auctions and our road trips down to Bordeaux for the bi-annual Vinexpo auction included some unforgettable lunches and dinners with great bottles shared. What a cheerful, amusing, interesting and positive person David was. He will be very sadly missed and I feel fortunate to have known him."

Tom Hudson, Farr Vintners

"David was a breath of fresh air - always cheerful, wonderfully well-informed, a live wire and extremely generous with his time. I had the pleasure of seeing him in action as the most energetic auctioneer imaginable for the global literacy charity Room to Read in both London and Asia. He will be missed enormously."

Jancis Robinson MW

"David - memories of boundless energy - part Tigger, part Mick Jagger, the rock star of the wine auction world. He wore his deep knowledge of wine lightly, and his integrity and professionalism were internationally admired. But I will remember him most for his humour, kindness and modesty – one of the good guys. "

Sarah Kemp, MD Decanter Magazine 1997-2017

It's with great sadness that last September we had to say goodbye to our beloved David Elswood. The Christie's Fine Wines auctions in Hong-Kong were among his personal achievements, he very much enjoyed being in the rostrum and always loved coming here. Its within his footsteps we continue and he would have been honored to write the introduction to this fine auction, as I am.

We will start this auction with a fine collection of great wines from a private cellar in Continental Europe featuring Petrus and Le Pin 2010 in pristine cases. Next on offer is a small private collection of original wooden cases of high quality Bordeaux from the eighties all bought on release and in exceptional quality, the highlight is a very rare case of Leroy Clos-Vougeot 1990. We are very proud of the next collection which was recently packed from a private cellar in France, spanning the great classic regions with many treasures like Romanée-Conti 1989. Last May we offered a fantastic private collection of finest Mosel wines from Egon Müller and JJ Prüm, this was well received. We are there for proud to offer a further small selection of top quality wines including the legendary 1975, 1976 and 1983 vintages. All impeccably stored. At Christie's we are specialized in rare and old Madeira wines. The buyer base of these rarities is ever expanding. Hence it wasn't a surprise to us that the small selection of Madeira's we offered in November 2018 was well received. In this auction we offer the second small selection of only the best and most rare Madeira's back to 1801.

The second part of this auction starts with an exceptional collection of a friend of Christie's. We are delighted to offer you the chance to acquire some true legends like Mouton Rothschild 1945 and Romanée-Conti 1999. This collection is completed with a fine range of Domaine Leroy and d'Auvenay. Following a fine small offer of grand- and premier cru Burgundy, including La Tache 1989, the sale continues with a beautiful collection of fine Bordeaux, Burgundy and Tuscan wines. All in from recent vintages and in original wooden cases. Domaine Leroy is one of the best producers of fine Burgundy, the limited quantity makes them highly sought after. We are therefore exceptionally proud to offer you this superb collection of Leroy featuring 21 different wines from a diversity 20 vintages. After the amazing success of our first Whisky offering its with whole hearted recommendation we can advise you to try your luck on the fine Whiskies in this auction featuring rare Karuizawa.

This part of the auction is concluded with mixed small collections of finest and rarest wines featuring magnums 1947 Petrus and Cheval Blanc, mixed claret, Leroy Musigny 1990, H. Jayer Richebourg 1985 and ex cellars Kistler.

With an exceptional collection of fine wines of the world we continue this Fine & Rare Wines sale. A striking diversity with many highlights from Ponsot, Screaming Eagle and Clos de Tart. But also more rising stars like Cerbaiona, Arnaud Ente and Michel Magnien are not to be missed.

The fore last collection is a very special one. This was the last project which David worked on, he described and packed this cellar personally. Beautiful full dozens of Lafite and Latour 1989, Mouton 1961 and a range of Hermitage La Chapelle 1983 are featured among many fine other fine wines.

Then we conclude the auction of this Hong Kong sale season with a mixed bag of charity lots of Decanter Award wines. Fine mixed dozens or more of surprise wines from the most recent tastings all offered without reserve.

We look forward to welcoming you to our sale room in the Hong Kong Convention and Exhibition Centre on 23 November to raise a glass to David. When you have any questions about the lots in this sale or our upcoming auctions for 2020 please contact our specialist team for more information.

Edwin Vos

Director, Head of Wine Sales Continental Europe

今年9月，我們懷著不捨的心情送別大衛·艾士維(David Elswood)。大衛對佳士得香港珍罕名釀拍賣貢獻良多，他非常享受主持拍賣，也經常參與其中。我們會跟隨他的腳步前行，相信他會為曾經執筆於圖錄介紹名酒拍賣而感到榮幸，一如此刻的我。

拍賣以歐洲大陸私人窖藏的名酒揭開序幕，當中包括柏翠莊(Petrus)和里騰莊(Le Pin)2010年份原箱珍藏。然後是一小批80年代的原箱波爾多私人窖藏，全部也於首度推出市場時購買，品質上乘，其中以一箱難得一見的勒樺酒莊伏舊特級園1990年份陳釀最備受注目。另一批我們引以為傲的名酒，最近才於法國私人酒窖裝箱，其產地橫跨多個經典產酒區，例如羅曼尼康帝莊(Romanée-Conti)1989年份名釀。去年5月，佳士得帶來伊貢米勒酒莊(Egon Müller)和普朗酒莊(JJ Prüm)的頂級摩澤爾葡萄酒私人珍藏，反應極佳，這次亦有幸呈獻另一批精選摩澤爾佳釀，包括1975、1976及1983等傳奇年份，儲存環境皆無與倫比。佳士得也是罕有陳年馬德拉酒拍賣的專家，而這些珍罕美酒的買家亦與日俱增，因此我們在2018年11月推出的精選馬德拉酒深受歡迎，亦屬意料中事。是次拍賣將會推出第二批馬德拉酒，全部均為最罕有的極尚馬德拉名釀，當中歷史最悠久的更可遠溯至1801年。

拍賣的第二部分首先呈獻一位佳士得好友的極級窖藏。藏家有機會購藏傳奇名莊的珍品，例如木桐莊(Mouton Rothschild)1945年份和羅曼尼康帝莊1999年份珍藏，更有勒樺莊及奧維那酒莊(d'Auvenay)的醇美出品。緊接登場的是勃艮第特級及一級園的名釀，包括拉塔希莊(La Tache)1989年份葡萄酒，然後還有波爾多、勃艮第和托斯卡納的精彩窖藏，全部均為近期年份佳釀，並附以原裝木箱。勒樺莊是勃艮第最炙手可熱的名莊，因為產量稀少而備受藏家渴求，而是次拍賣卻能蒐羅勒樺莊20個年份的21款名釀，實在難能可貴。佳士得的首個威士忌拍賣反應熱烈，現在我們亦誠意推薦今季悉心蒐羅的醇美威士忌，當中包括珍罕的輕井澤威士忌。

這一部分的壓軸之作是多批特級罕有名酒，包括1.5公升裝柏翠莊1947年份葡萄酒、白馬莊(Cheval Blanc)1947年份佳釀、各款紅酒、勒樺莊慕西尼園1990年份葡萄酒、李奇堡(H. Jayer Richebourg)1985年份陳釀及吉斯特勒酒莊(Kistler)直送的美酒。

珍罕名釀拍賣其他不容錯過的臻美名酒，還有多瓶來自彭壽莊(Ponsot)、嘯鷹莊(Screaming Eagle)和大德園(Clos de Tart)的頂級之作。此外，謝百歐納酒莊(Cerbaiona)、阿爾諾昂斯酒莊(Arnaud Ente)和蜜雪兒·馬尼安酒莊(Michel Magnien)等新晉酒莊的傑作也值得期待。

最後一批窖藏非常特別，這也是大衛最後負責的項目，並由他親自記錄和包裝。這批窖藏包括數十瓶拉菲莊(Lafite)和拉圖莊(Latour)1989年份、木桐莊1961年份和多瓶埃米塔日教堂園(Hermitage La Chapelle)1983年份陳釀，另外還有多瓶頂級醇釀。

今季的香港拍賣將以慈善拍賣作結，呈獻Decanter葡萄酒大賽的得獎佳釀，數十瓶美酒皆為最近剛經過品酒評鑑的驚喜之作，而且全部不設底價。

珍罕名釀拍賣將於11月23日假香港會議展覽中心舉行，歡迎親臨參與拍賣，並向大衛舉杯致敬。如閣下對拍品或2020年的拍賣有任何疑問，歡迎向佳士得專家團隊查詢。

埃德溫·沃斯(Edwin Vos)

歐洲區名酒銷售總監及主管

SATURDAY 23 NOVEMBER · 10.30AM

Lots 5001-5839

FINE & RARE WINES AND SPIRITS FEATURING AN EXCEPTIONAL PRIVATE COLLECTION AND
A COLLECTION OF CENTURY OLD MADEIRA

佳士得珍罕名釀及烈酒：呈獻顯赫私人珍藏及馬德拉酒百年極尚窖藏

The following lots 5001 to 5063 feature a fine collection of great wines from a private cellar in Continental Europe featuring Petrus and Le Pin 2010 in pristine cases.

Château Montrose 1990

Saint-Estéphe, 2ème cru classé

In original wooden case. Three damaged capsules. Pristine labels.

Levels: into neck

5001 6 bottles *per lot* HK\$24,000-35,000

Château Montrose 2009

Saint-Estéphe, 2ème cru classé

In original wooden case

5002 12 bottles *per lot* HK\$17,000-26,000

Mixed Château Montrose & Château Lafite Rothschild

1990 Château Montrose

Pristine label. Level: into neck

half-bottle (1)

1996 Château Lafite Rothschild

One stained label

half-bottles (3)

5003 4 half-bottles *per lot* HK\$11,000-15,000

Château Lafite-Rothschild 1986

Pauillac, 1er cru classé

In original wooden case. In original tissue. Excellent appearance.

Pristine label. Levels: into neck

5004 1 imperial *per lot* HK\$50,000-80,000

Château Lafite-Rothschild 2003

Pauillac, 1er cru classé

In banded original wooden case

5005 12 bottles *per lot* HK\$75,000-120,000

Château Lafite-Rothschild 2009

Pauillac, 1er cru classé

In banded six-bottle original wooden case

5006 12 bottles *per lot* HK\$60,000-90,000

Château Lafite-Rothschild 2010

Pauillac, 1er cru classé

In banded original wooden case

5007 6 bottles *per lot* HK\$28,000-42,000

Château Mouton-Rothschild 2002

Pauillac, 1er cru classé

In original wooden case

5008 3 magnums *per lot* HK\$17,000-24,000

Château Mouton-Rothschild 2005

Pauillac, 1er cru classé

In original wooden case

5009 1 magnum *per lot* HK\$7,000-10,000

Château Mouton-Rothschild 2006

Pauillac, 1er cru classé

In banded original wooden case

5010 6 bottles *per lot* HK\$20,000-30,000

Château Latour 1982

Pauillac, 1er cru classé

Very slightly bin-soiled label. Level: base of neck

5011 1 magnum *per lot* HK\$20,000-30,000

Château Latour 1996

Pauillac, 1er cru classé

In original wooden case. In original tissues. Slightly damaged

capsules. Pristine labels. Levels: into neck

5012 6 magnums *per lot* HK\$55,000-80,000



Lot 5012

Please note lots 5001 to 5210 will be available for collection or delivery after 16 December 2019.

Château Latour 2005*Pauillac, 1er cru classé
In original wooden cases*5013 6 bottles *per lot* HK\$24,000-38,000
5014 6 "**Château Latour 2010***Pauillac, 1er cru classé
In original wooden case*5015 6 bottles *per lot* HK\$40,000-60,000**Château Grand-Puy-Lacoste 1995***Pauillac, 5ème cru classé
In original wooden case*5016 12 bottles *per lot* HK\$7,500-11,000**Château Léoville-Barton 1986***Saint-Julien, 2ème cru classé
In original wooden case. Two slightly damaged labels, otherwise
pristine. Levels: four base of neck, one very top shoulder, four top
shoulder, two upper shoulder, one upper/mid-shoulder*5017 12 bottles *per lot* HK\$8,500-13,000**Château Léoville-Las-Cases 2009***Saint-Julien, 2ème cru classé
In original wooden case*5018 3 magnums *per lot* HK\$8,500-12,000**Château Léoville-Poyferré 2009***Saint-Julien, 2ème cru classé
In original wooden case*5019 12 bottles *per lot* HK\$13,000-19,000**Château Talbot 1990***Saint-Julien, 4ème cru classé
In original wooden case. Pristine labels. Levels: into neck*5020 11 bottles *per lot* HK\$7,000-10,000**Château Margaux 2000***Margaux, 1er cru classé
In six-bottle original wooden cases*5021 12 bottles *per lot* HK\$55,000-85,000**Château Margaux 2005***Margaux, 1er cru classé
In original wooden cases*5022 6 bottles *per lot* HK\$26,000-40,000
5023 6 "**Mixed Château Margaux****1986**
Damaged capsule. Pristine label. Level: base of neck (1)**1989**
Pristine label. Level: base of neck (1)**1990**
Slightly damaged and slightly stained label. Level: into neck (1)5024 3 bottles *per lot* HK\$11,000-17,000**Château Palmer 1989***Cantenac (Margaux), 3ème cru classé
In original wooden case. Three damaged capsules. Four slightly
damaged labels. Levels: six into neck, five base of neck, one top
shoulder*5025 12 bottles *per lot* HK\$28,000-40,000

Lot 5025

	Château Palmer 2005 <i>Cantenac (Margaux), 3ème cru classé</i> <i>In original wooden case</i>				Petrus 2006 <i>Pomerol, cru exceptionnel</i> <i>In original wooden case</i>		
5026	5 magnums		<i>per lot</i>	HK\$18,000-26,000	5034	6 bottles	<i>per lot</i> HK\$85,000-130,000
	Château Palmer 2005 <i>Cantenac (Margaux), 3ème cru classé</i> <i>In original wooden case</i>				Petrus 2008 <i>Pomerol, cru exceptionnel</i> <i>In banded original wooden case</i>		
5027	6 bottles		<i>per lot</i>	HK\$11,000-17,000	5035	1 magnum	<i>per lot</i> HK\$32,000-48,000
	Château Haut-Brion 2000 <i>Pessac (Graves), 1er cru classé</i> <i>In original wooden case</i>				Petrus 2010 <i>Pomerol, cru exceptionnel</i> <i>In original wooden case</i>		
5028	6 bottles		<i>per lot</i>	HK\$24,000-38,000	5036	6 bottles	<i>per lot</i> HK\$120,000-180,000
	Château Pape-Clément 2005 <i>Pessac (Graves), cru classé</i> <i>In original wooden case</i>				Le Pin 2009 <i>Pomerol</i> <i>In original wooden case</i>		
5029	6 bottles		<i>per lot</i>	HK\$6,000-9,000	5037	1 magnum	<i>per lot</i> HK\$48,000-70,000
	Château Laville-Haut-Brion 2006 <i>Talence (Graves), cru classé</i> <i>In original wooden case</i>				Le Pin 2009 <i>Pomerol</i> <i>In original wooden case</i>		
5030	6 bottles		<i>per lot</i>	HK\$10,000-15,000	5038	4 bottles	<i>per lot</i> HK\$95,000-140,000
	Mixed Château La Mission Haut Brion				Le Pin 2010 <i>Pomerol</i> <i>In banded original wooden case</i>		
	1986 <i>Slightly damaged capsule. Pristine label. Level: very top shoulder</i> (1)				5039	6 bottles	<i>per lot</i> HK\$130,000-200,000
	1989 <i>Pristine label. Levels: into neck</i> (1)						
	1990 <i>Pristine labels. Levels: into neck</i> (2)				Château Lafleur 2006 <i>Pomerol</i> <i>In original wooden case</i>		
5031	4 bottles		<i>per lot</i>	HK\$16,000-24,000	5040	3 magnums	<i>per lot</i> HK\$16,000-22,000
	Petrus 2003 <i>Pomerol, cru exceptionnel</i>				Mixed Château Lafleur		
5032	1 bottle		<i>per lot</i>	HK\$14,000-20,000	2000		(1)
	Petrus 2006 <i>Pomerol, cru exceptionnel</i> <i>In banded original wooden case</i>				2005		(1)
5033	1 magnum		<i>per lot</i>	HK\$28,000-42,000	5041	2 bottles	<i>per lot</i> HK\$16,000-24,000

Château L'Église Clinet 2005

Pomerol

In original wooden case

5042 6 magnums *per lot* HK\$32,000-48,000

Château L'Évangile 2009

Pomerol

In original wooden case with damaged lid

5043 12 bottles *per lot* HK\$20,000-30,000

Château La Violette 2009

Pomerol

In original wooden case

5044 3 magnums *per lot* HK\$14,000-20,000

Château La Violette 2010

Pomerol

In original wooden case

5045 6 bottles *per lot* HK\$50,000-75,000

Château Bellevue 2000

Saint-Émilion, grand cru

In six-bottle original wooden cases

5046 12 bottles *per lot* HK\$7,500-11,000

Château Troplong-Mondot 2005

Saint-Émilion, 1er grand cru classé (B)

In original wooden case

5047 6 magnums *per lot* HK\$18,000-26,000

Château La Mondotte 2000

Saint-Émilion, grand cru classé

In original wooden case

5048 6 bottles *per lot* HK\$11,000-17,000

Château L'IF 2012

Saint-Émilion

In original wooden case

5049 6 bottles *per lot* HK\$6,000-9,500



Lot 5042



Lot 5050

Mixed Château d'Yquem
1971
Pristine label. Level: base of neck (1)
1982
Slightly stained label. Level: base of neck (1)
2001 half-bottle (1)
5050 2 bottles and 1 half-bottle *per lot* HK\$5,500-8,500

Mixed Sauternes
2005 Château Nairac
In original wooden case (12)
2005 Château Rieussec
In original wooden case (12)
1989 Château La Tour Blanche
One slightly bin-soiled label. Levels: one into neck, one base of neck (2)
2005 Château La Tour Blanche
In original wooden case (12)
2006 Château La Tour Blanche
In original wooden case (10)
5051 48 bottles *per lot* HK\$9,500-14,000

M. Chapoutier, Ermitage Le Pavillon 2003
Rhône
In original wooden case
5052 6 bottles *per lot* HK\$7,000-10,000

M. Chapoutier, Ermitage Les Greffieux 2006
Rhône
In banded original wooden case
5053 6 bottles *per lot* HK\$6,500-10,000

Mixed M. Chapoutier, Ermitage Le Meal Blanc & Rouge
2004 Ermitage Le Meal Blanc (6)
2003 Ermitage Le Meal (6)
In six-bottle original wooden cases
5054 12 bottles *per lot* HK\$9,500-15,000

Mixed Rhône
2009 Domaine Jean-Louis Chave, Hermitage Blanc (1)
2003 E. Guigal, Côte-Rôtie La Turque (1)
2005 E. Guigal, Côte-Rôtie La Landonne (1)
5055 3 bottles *per lot* HK\$7,500-10,000

Domaine de la Romanée-Conti, Romanée-Saint-Vivant 2006
Grand Cru, Côte de Nuits
5056 1 bottle *per lot* HK\$11,000-17,000

Domaine Dugat-Py, Chambertin 2002
Grand Cru, Côte de Nuits
5057 1 bottle *per lot* HK\$14,000-20,000

Domaine Dugat-Py, Chambertin 2005
Grand Cru, Côte de Nuits
5058 1 bottle *per lot* HK\$16,000-24,000

Château de Pommard Pommard Cuvée Jean-Louis Laplanche 1982
Côte de Beaune
In original wooden case with damaged lid. Scuffed capsules. Bin-soiled labels. Levels: one 2cms, two 2.5cms, eight 3.5cms, one 4cms
5059 12 bottles *per lot* HK\$7,500-11,000

Mixed Burgundy
2002 Domaine Jacques Prieur, Clos de Vougeot (1)
1990 Domaine Clos des Lambrays, Morey-Saint-Denis Premier Cru
Level: 2cms (1)
5060 2 bottles *per lot* HK\$13,000-20,000

Mixed Italy
2004 Dal Forno Romano Amarone della Valpolicella (1)
2007 Solaia Antinori
In original wooden case (6)
5061 7 bottles *per lot* HK\$8,500-12,000



Lot 5059

Mixed Sine Qua Non**2003 Papa Syrah**

magnum (1)

2006 A Shot in the Dark Syrah

(1)

5062 1 magnum and 1 bottle per lot HK\$13,000-19,000

Mixed Penfolds Grange**1996***In original wooden case*

(6)

2001

(1)

5063 7 bottles per lot HK\$16,000-24,000

AN IMMACULATE BORDEAUX COLLECTION

The following lots 5064 to 5075 feature an impressive selection of finest & rarest wines from Bordeaux of original wooden cases from the eighties all bought on release and in exceptional quality. Highlights include mature vintages of Cru Classé Bordeaux from the 1980's and 1990's, which I am sure will be a delight to taste, explore and enjoy.

Château Lafite-Rothschild 1986*Pauillac, 1er cru classé**In original wooden case. In original tissues. Excellent appearance.**Pristine labels. Levels: into neck*

5064 6 magnums per lot HK\$80,000-120,000

Château Lafite-Rothschild 1986*Pauillac, 1er cru classé**In original wooden case. In original tissues. Excellent appearance.**Pristine labels. Levels: into neck*

5065 24 half-bottles per lot HK\$65,000-100,000

Château Lafite-Rothschild 2000*Pauillac, 1er cru classé**In original wooden case*

5066 12 bottles per lot HK\$110,000-160,000

Château Mouton-Rothschild 1986*Pauillac, 1er cru classé**Nine in original tissues. Four slightly damaged labels, eight pristine.**Levels: eight base of neck, four top shoulder*

5067 12 bottles per lot HK\$40,000-60,000

Château Latour 1990*Pauillac, 1er cru classé**In original wooden case. In original tissues. Excellent appearance.**Pristine labels. Levels: nine into neck, three base of neck*

5068 12 bottles per lot HK\$55,000-85,000

Château Lynch Bages 1982*Pauillac, 5ème cru classé**In original wooden case. Slightly damaged wax capsule. Pristine label. Level: into neck*

5069 1 double-magnum per lot HK\$8,500-13,000

Château Léoville-Las-Cases 1982*Saint-Julien, 2ème cru classé**In original wooden case. US import slip labels. Scuffed capsules, two damaged. One raised cork. Levels: eight into neck, four base of neck*

5070 12 bottles per lot HK\$30,000-35,000

Château Gruaud-Larose 1982*Saint-Julien, 2ème cru classé**Three damaged capsules. Five slightly damaged labels. Levels: into neck*

5071 12 bottles per lot HK\$30,000-35,000

Château Margaux 1986*Margaux, 1er cru classé**In original wooden case. Excellent appearance. Pristine labels.**Levels: into neck*

5072 12 bottles per lot HK\$42,000-60,000

Château Margaux 1986*Margaux, 1er cru classé**In original wooden case. Excellent appearance. Pristine labels.**Levels: into neck*

5073 24 half-bottles per lot HK\$42,000-60,000



Château Haut-Brion 1989

Pessac (Graves), 1er cru classé
 In original wooden case. Excellent appearance. Pristine labels.
 Levels: 1cm or better

5074 12 bottles per lot HK\$170,000-200,000

Domaine Leroy, Clos de Vougeot 1990

Grand Cru, Côte de Nuits
 In original wooden case. #3978-3989 of a total 4790 bottles made.
 Signs of old seepage. One damaged wax capsule. One slightly
 stained label. Levels: seven 1cm, five 1.5cms

5075 12 bottles per lot HK\$220,000-320,000

The following lots 5076 to 5163 was recently packed from a private cellar
 in France, spanning the great classic regions with many treasures like
 Romanée-Conti 1989.

Château Lafite-Rothschild 1989

Pauillac, 1er cru classé
 Three damaged capsules. Pristine labels. Levels: one into neck, two
 base of neck

5076 3 bottles per lot HK\$14,000-20,000

Château Lafite-Rothschild 2000

Pauillac, 1er cru classé

5077 6 bottles per lot HK\$48,000-75,000

Château Mouton-Rothschild 1985

Pauillac, 1er cru classé
 Slightly damaged capsule. Bin-soiled label. Level: into neck

5078 1 jeroboam per lot HK\$20,000-26,000

Château Mouton-Rothschild 1986

Pauillac, 1er cru classé
 Corroded capsules. Slightly damaged labels. Levels: two into neck,
 two base of neck, one just below top shoulder, one upper shoulder

5079 6 bottles per lot HK\$32,000-48,000

Château Mouton-Rothschild 1990

Pauillac, 1er cru classé
 Pristine labels. Levels: base of neck or better

5080 6 bottles per lot HK\$15,000-22,000

Château Mouton-Rothschild 1994

Pauillac, 1er cru classé
 Bin-soiled labels, two badly damaged and stained

5081 5 bottles per lot HK\$13,000-19,000

Château Mouton-Rothschild 2006

Pauillac, 1er cru classé
 Six slightly bin-soiled and damaged labels

5082 12 bottles per lot HK\$40,000-60,000

Château Mouton-Rothschild 2009

Pauillac, 1er cru classé

5083 3 bottles per lot HK\$10,000-16,000

Château Mouton-Rothschild 2010

Pauillac, 1er cru classé

5084 3 bottles per lot HK\$11,000-17,000

Mixed Château Mouton-Rothschild**1984**

Stained label. Level: into neck

(1)

2004

(1)

2007

(1)

5085 3 bottles per lot HK\$7,000-10,000

Château Latour 1989

Pauillac, 1er cru classé

Excellent appearance. Levels: into neck

5086 6 bottles per lot HK\$17,000-26,000

Château Latour 2002

Pauillac, 1er cru classé

All slightly bin-soiled labels. Six damaged labels

5087 10 bottles per lot HK\$30,000-45,000

Château Margaux 1993

Margaux, 1er cru classé

All slightly bin-soiled labels

5088 6 bottles per lot HK\$13,000-20,000

Château Margaux 2006

Margaux, 1er cru classé

All slightly bin-soiled labels

5089 6 bottles per lot HK\$14,000-22,000



Lots 5083 & 5084

Mixed Château Latour and Château Margaux
2004 Château Latour (2)
1994 Château Margaux
Bin-soiled stained and damaged label. Level: into neck (1)
2004 Château Margaux (1)
5090 4 bottles *per lot* HK\$9,500-15,000

Mixed Château Ducru-Beaucaillou
1986
One damaged capsule. Slightly damaged labels. Levels: into neck (3)
1988
Levels: into neck (2)
1989
Very slightly damaged labels. Levels: into neck (3)
2003 (6)
5091 14 bottles *per lot* HK\$13,000-19,000

Mixed Château Haut-Brion
1994
Bin-soiled and slightly damaged labels. Levels: 1cm (2)
2004
Bin-soiled and slightly damaged label (1)
2006
Bin-soiled and slightly damaged labels (3)
5092 6 bottles *per lot* HK\$14,000-20,000

Mixed Bordeaux Left Bank
2003 Château Cos d'Estournel (3)
One damaged label
2003 Château Calon Ségur (6)
Slightly damaged labels
2005 Château Pichon-Longueville, Lalande (6)
2007 Château Giscours (6)
2000 Château Cantemerle (3)
1998 Château d'Yquem (3)
5093 27 bottles *per lot* HK\$16,000-26,000

Petrus 1974
Pomerol, cru exceptionnel
Corroded capsule. Damaged and bin-soiled label. Level: top shoulder
5094 1 bottle *per lot* HK\$9,000-13,000

Petrus 1989
Pomerol, cru exceptionnel
Slightly corroded and damaged capsules. Levels: into neck
5095 2 bottles *per lot* HK\$48,000-70,000

Petrus 1997
Pomerol, cru exceptionnel
Bin-soiled and slightly damaged labels. Levels: into neck
5096 4 bottles *per lot* HK\$48,000-70,000

Petrus 2002
Pomerol, cru exceptionnel
One marked label
5097 2 bottles *per lot* HK\$28,000-45,000

Petrus 2004
Pomerol, cru exceptionnel
5098 1 bottle *per lot* HK\$13,000-20,000

Mixed Bordeaux Right Bank
1996 Château Angelus (2)
2004 Château Cheval Blanc
Very slightly damaged label (1)
2007 Château L'Evangile (3)
5099 6 bottles *per lot* HK\$7,000-10,000

Domaine de la Romanée-Conti, Romanée-Conti 1974
Grand Cru, Côte de Nuits
Corroded capsule. Very badly bin-soiled and damaged label. Level: 5.5cms
5100 1 bottle *per lot* HK\$60,000-90,000

Domaine de la Romanée-Conti, Romanée-Conti 1989
Grand Cru, Côte de Nuits
In original wooden case. Three marked labels, one damaged. Levels: four 1.5cms, two 2cms
5101 6 bottles *per lot* HK\$650,000-950,000

Domaine de la Romanée-Conti, Romanée-Conti 1996
Grand Cru, Côte de Nuits
Slightly damaged label
5102 1 bottle *per lot* HK\$100,000-150,000

Domaine de la Romanée-Conti, Romanée-Conti 2001
Grand Cru, Côte de Nuits
5103 1 bottle *per lot* HK\$100,000-150,000

Domaine de la Romanée-Conti, Romanée-Conti 2006
Grand Cru, Côte de Nuits
5104 1 bottle *per lot* HK\$100,000-150,000

Domaine de la Romanée-Conti, Romanée-Conti 2012
Grand Cru, Côte de Nuits
5105 1 bottle *per lot* HK\$100,000-150,000

Domaine de la Romanée-Conti, La Tâche 2007
Grand Cru, Côte de Nuits
5106 1 bottle *per lot* HK\$20,000-30,000

Domaine de la Romanée-Conti, La Tâche 2009
Grand Cru, Côte de Nuits
5107 1 bottle *per lot* HK\$22,000-35,000

Domaine de la Romanée-Conti, La Tâche 2010
Grand Cru, Côte de Nuits
5108 1 bottle *per lot* HK\$22,000-35,000



MONOPOLE
1989

MONOPOLE
1989

MONOPOLE
1989

SOCIÉTÉ CIVILE DU DOMAINE DE LA ROMANÉE-CONTI
PROPRIÉTAIRE À VOSNE-ROMANÉE (CÔTE-D'OR) FRANCE

ROMANÉE-CONTI
APPELLATION ROMANÉE-CONTI CONTRÔLÉE

0,723 Bouteilles Recollées

BOUTEILLE N° 01737
ANNÉE 1989

LES ASSOCIÉS-GÉRANTS
*in Leroy 1736
A. d. V. d. B. d. M.*

Mise en bouteille au domaine

SOCIÉTÉ CIVILE DU DOMAINE DE LA ROMANÉE-CONTI
PROPRIÉTAIRE À VOSNE-ROMANÉE (CÔTE-D'OR) FRANCE

ROMANÉE-CONTI
APPELLATION ROMANÉE-CONTI CONTRÔLÉE

0,723 Bouteilles Recollées

BOUTEILLE N° 01738
ANNÉE 1989

LES ASSOCIÉS-GÉRANTS
*in Leroy 1736
A. d. V. d. B. d. M.*

Mise en bouteille au domaine

SOCIÉTÉ CIVILE DU DOMAINE DE LA ROMANÉE-CONTI
PROPRIÉTAIRE À VOSNE-ROMANÉE (CÔTE-D'OR) FRANCE

ROMANÉE-CONTI
APPELLATION ROMANÉE-CONTI CONTRÔLÉE

0,723 Bouteilles Recollées

BOUTEILLE N° 01743
ANNÉE 1989

LES ASSOCIÉS-GÉRANTS
*in Leroy 1736
A. d. V. d. B. d. M.*

Mise en bouteille au domaine

ROMANÉE-CONTI

CONTI

RO

MONOPOLE
1989

MONOPOLE
1989

MONOPOLE
1989

SOCIÉTÉ CIVILE DU DOMAINE DE LA ROMANÉE-CONTI
PROPRIÉTAIRE À VOSNE-ROMANÉE (CÔTE-D'OR) FRANCE

ROMANÉE-CONTI
APPELLATION ROMANÉE-CONTI CONTRÔLÉE

0,723 Bouteilles Recollées

BOUTEILLE N° 01742
ANNÉE 1989

LES ASSOCIÉS-GÉRANTS
*in Leroy 1736
A. d. V. d. B. d. M.*

Mise en bouteille au domaine

SOCIÉTÉ CIVILE DU DOMAINE DE LA ROMANÉE-CONTI
PROPRIÉTAIRE À VOSNE-ROMANÉE (CÔTE-D'OR) FRANCE

ROMANÉE-CONTI
APPELLATION ROMANÉE-CONTI CONTRÔLÉE

0,723 Bouteilles Recollées

BOUTEILLE N° 01736
ANNÉE 1989

LES ASSOCIÉS-GÉRANTS
*in Leroy 1736
A. d. V. d. B. d. M.*

Mise en bouteille au domaine

SOCIÉTÉ CIVILE DU DOMAINE DE LA ROMANÉE-CONTI
PROPRIÉTAIRE À VOSNE-ROMANÉE (CÔTE-D'OR) FRANCE

ROMANÉE-CONTI
APPELLATION ROMANÉE-CONTI CONTRÔLÉE

0,723 Bouteilles Recollées

BOUTEILLE N° 01740
ANNÉE 1989

LES ASSOCIÉS-GÉRANTS
*in Leroy 1736
A. d. V. d. B. d. M.*

Mise en bouteille au domaine

Domaine de la Romanée-Conti, La Tâche 2013
Grand Cru, Côte de Nuits
 5109 3 bottles *per lot* HK\$65,000-100,000

Domaine de la Romanée-Conti, La Tâche 2014
Grand Cru, Côte de Nuits
 5110 1 bottle *per lot* HK\$20,000-28,000

Domaine de la Romanée-Conti, Echézeaux 2007
Grand Cru, Côte de Nuits
Marked label
 5111 1 bottle *per lot* HK\$9,500-14,000

Domaine de la Romanée-Conti, Echézeaux 2009
Grand Cru, Côte de Nuits
Marked label
 5112 1 bottle *per lot* HK\$11,000-16,000

Domaine de la Romanée-Conti, Echézeaux 2012
Grand Cru, Côte de Nuits
Marked label
 5113 1 bottle *per lot* HK\$9,500-14,000

Domaine de la Romanée-Conti, Richebourg 2006
Grand Cru, Côte de Nuits
Damaged label with tissue attached
 5114 1 bottle *per lot* HK\$13,000-20,000

Domaine de la Romanée-Conti, Richebourg 2007
Grand Cru, Côte de Nuits
 5115 1 bottle *per lot* HK\$13,000-20,000

Domaine de la Romanée-Conti, Richebourg 2008
Grand Cru, Côte de Nuits
 5116 1 bottle *per lot* HK\$14,000-20,000

Domaine de la Romanée-Conti, Richebourg 2009
Grand Cru, Côte de Nuits
 5117 1 bottle *per lot* HK\$16,000-24,000

Domaine de la Romanée-Conti, Richebourg 2010
Grand Cru, Côte de Nuits
Marked label
 5118 1 bottle *per lot* HK\$16,000-24,000



Lot 5122

Domaine de la Romanée-Conti, Richebourg 2013
Grand Cru, Côte de Nuits
 5119 2 bottles *per lot* HK\$24,000-38,000

Domaine de la Romanée-Conti, Romanée-Saint-Vivant 2001
Grand Cru, Côte de Nuits
Slightly stained labels
 5120 2 bottles *per lot* HK\$24,000-35,000

Domaine de la Romanée-Conti, Romanée-Saint-Vivant 2013
Grand Cru, Côte de Nuits
Two slightly damaged labels
 5121 3 bottles *per lot* HK\$32,000-50,000

Domaine de la Romanée-Conti Assortment 2012

Romanée-Conti	(1)
La Tâche	(2)
Echézeaux	(1)
Richebourg	(1)
Romanée-Saint-Vivant	(1)

5122 6 bottles *per lot* HK\$180,000-260,000

Domaine de la Romanée-Conti Assortment 2015

Romanée-Conti	(1)
La Tâche	(1)
Echézeaux	(1)
Grands-Echézeaux	(1)
Romanée-Saint-Vivant	(1)
Montrachet	(1)

5123 6 bottles *per lot* HK\$240,000-350,000

Domaine Armand Rousseau, Chambertin 2001
Grand Cru, Côte de Nuits
 5124 1 bottle *per lot* HK\$14,000-20,000

Domaine Armand Rousseau, Chambertin 2002
Grand Cru, Côte de Nuits
Nicked label
 5125 1 bottle *per lot* HK\$16,000-24,000

Domaine Armand Rousseau, Chambertin 2008
Grand Cru, Côte de Nuits
 5126 2 bottles *per lot* HK\$22,000-32,000

Domaine Armand Rousseau, Chambertin 2014
Grand Cru, Côte de Nuits
 5127 1 bottle *per lot* HK\$10,000-15,000



Lots 5124-5127

Mixed Domaine Armand Rousseau, Clos des Ruchottes
2011 (1)
2012 (4)
 5128 5 bottles per lot HK\$15,000-24,000

Mixed Domaine Armand Rousseau, Mazy & Charmes-Chambertin
2010 Mazy-Chambertin (1)
2011 Mazy-Chambertin (1)
2008 Charmes-Chambertin
Believed 2008; vintage on neck label missing (1)
2011 Charmes-Chambertin (1)
2012 Charmes-Chambertin (2)
 5129 6 bottles per lot HK\$13,000-20,000

Mixed Domaine Armand Rousseau
2005 Gevrey-Chambertin, Clos Saint-Jacques (1)
2012 Gevrey-Chambertin, Lavaux Saint-Jacques 1er Cru (3)
 5130 4 bottles per lot HK\$13,000-18,000

Mixed Coche Dury, Meursault
2001 (2)
2007 (4)
2009 (2)
2010 (1)
2011 (2)
 5131 11 bottles per lot HK\$35,000-55,000

Mixed Coche Dury, Puligny-Meursault
2004 Rougets
Damaged label (1)
2011 Caillerets (1)
 5132 2 bottles per lot HK\$12,000-17,000

Mixed Coche Dury, Puligny-Montrachet Les Enseignères
1997 (1)
2004 (2)
All bin-soiled and damaged labels
 5133 3 bottles per lot HK\$11,000-17,000

Mixed Mommessin, Clos de Tart
2004
Damaged labels (2)
2011 (4)
 5134 6 bottles per lot HK\$10,000-15,000

Mixed Burgundy
2007 Domaine des Comtes Lafon Champans, Volnay (3)
2008 Domaine des Comtes Lafon Champans, Volnay
Stained labels (5)
2011 Domaine Leroy, Savigny-lès-Beaune Les Narbantons
One sign of old seepage on wax capsule. Levels: 2cms (2)
2012 Domaine Dujac, Vosne-Romanée 1er Cru Aux Malconsorts (2)
 5135 12 bottles per lot HK\$18,000-24,000



Lot 5139

Domaine Denis Mortet, Clos de Vougeot 2012
Grand Cru, Côte de Nuits
 5136 6 bottles *per lot* HK\$9,500-14,000

E. Guigal, Ermitage Ex-Voto 2003
Rhône
Slightly bin-soiled labels
 5137 6 bottles *per lot* HK\$11,000-17,000

Mixed E. Guigal, Côte-Rôtie La Landonne
2003 (1)
2005 (1)
Slightly bin-soiled label (1)
2009 (2)
2010 (2)
2011 (2)
2012 (2)
2013 (2)
 5138 12 bottles *per lot* HK\$24,000-38,000

Mixed E. Guigal, Côte-Rôtie La Mouline
2003 (1)
2005 (1)
2009 (2)
2010 (2)
2011 (2)
2012 (2)
2013 (2)
 5139 12 bottles *per lot* HK\$24,000-38,000

Mixed E. Guigal, Côte-Rôtie La Turquie
2003 (1)
2005 (1)
Nicked label (1)
2009 (2)
2010 (2)
2011 (2)
Signs of old seepage. One stained neck label (2)
2012 (2)
2013 (2)
 5140 12 bottles *per lot* HK\$22,000-35,000

Mixed Château de Beaucastel, Châteauneuf-du-Pape Blanc
2007 Châteauneuf-du-Pape Blanc Vieilles Vignes (3)
One sign of seepage. One stained and one damaged labels
2013 Châteauneuf-du-Pape Blanc Vieilles Vignes (6)
In original wooden case
2015 Châteauneuf-du-Pape Blanc Vieilles Vignes (6)
In three-bottle original wooden cases
2016 Châteauneuf-du-Pape Blanc Vieilles Vignes (6)
In original wooden case
2016 Châteauneuf-du-Pape Blanc (3)
 5141 24 bottles *per lot* HK\$16,000-26,000

Mixed Château de Beaucastel, Châteauneuf-du-Pape
2005 (1)
2015 (6)
In original wooden case
 5142 7 bottles *per lot* HK\$10,000-16,000

Mixed Château de Beaucastel, Châteauneuf-du-Pape Hommage à Jacques Perrin
2001 (3)
2005 (2)
 5143 5 bottles *per lot* HK\$16,000-26,000

Château de Beaucastel Châteauneuf-du-Pape Hommage à Jacques Perrin 2007
Rhône
Damaged labels
 5144 2 magnums *per lot* HK\$9,000-13,000

Château de Beaucastel, Châteauneuf-du-Pape Hommage à Jacques Perrin 2007
Rhône
 5145 6 bottles *per lot* HK\$13,000-20,000

Château de Beaucastel, Châteauneuf-du-Pape Hommage à Jacques Perrin 2009
Rhône
Damaged labels
 5146 2 magnums *per lot* HK\$7,000-10,000

Château de Beaucastel, Châteauneuf-du-Pape Hommage à Jacques Perrin 2009
Rhône
 5147 5 bottles *per lot* HK\$8,500-13,000

Château de Beaucastel, Châteauneuf-du-Pape Hommage à Jacques Perrin 2012

Rhône

5148 3 double-magnums *per lot* HK\$18,000-26,000

Mixed Formats of Château de Beaucastel, Châteauneuf-du-Pape Hommage à Jacques Perrin

2012

Two damaged labels

magnums (3)

2012

(1)

5149 3 magnums and 1 bottle *per lot* HK\$11,000-16,000

Château de Beaucastel, Châteauneuf-du-Pape Hommage à Jacques Perrin 2014

Rhône

In individual original wooden cases

5150 6 bottles *per lot* HK\$8,000-12,000

Château de Beaucastel, Châteauneuf-du-Pape Hommage à Jacques Perrin 2015

Rhône

In individual original wooden case

5151 1 double-magnum *per lot* HK\$6,000-9,000

Château de Beaucastel, Châteauneuf-du-Pape Hommage à Jacques Perrin 2015

Rhône

In individual original wooden cases

5152 3 magnums *per lot* HK\$9,000-14,000

Château de Beaucastel, Châteauneuf-du-Pape Hommage à Jacques Perrin 2015

Rhône

In original wooden cases

5153 6 bottles *per lot* HK\$9,000-14,000

5154 6 "

5155 6 "

Henri Bonneau, Châteauneuf-du-Pape Marie Beurrier 1999

Rhône

5156 6 bottles *per lot* HK\$7,000-11,000

Henri Bonneau, Châteauneuf-du-Pape Réserve de Célestins 2000

Rhône

One damaged label

5157 6 bottles *per lot* HK\$13,000-20,000

Henri Bonneau, Châteauneuf-du-Pape Réserve de Célestins 2007

Rhône

5158 6 bottles *per lot* HK\$15,000-22,000

Mixed Henri Bonneau, Châteauneuf-du-Pape Réserve de Célestins in Magnums

2004 magnum (1)

2005 magnum (1)

2006 magnum (1)

Damaged label magnum (1)

5159 3 magnums *per lot* HK\$13,000-20,000

Domaine Jean-Louis Chave, Ermitage Cuvée Cathelin 2000

Rhône

Very slightly damaged and bin-soiled labels

5160 2 bottles *per lot* HK\$55,000-80,000



Lot 5148



Mixed Domaine Jean-Louis Chave, Hermitage Blanc
2006 (2)
2007
One stained label (2)
2008 (2)
5161 6 bottles *per lot* HK\$5,500-8,000

Mixed Domaine Jean-Louis Chave, Hermitage Rouge
2004
Two slightly damaged labels (4)
2005
One stained and damaged label (2)
2006
Two nicked and stained labels (3)
2007 (3)
2008 (3)
5162 15 bottles *per lot* HK\$18,000-26,000

Mixed Domaine Jean-Louis Chave, Hermitage Blanc & Rouge
2013 Hermitage Blanc (3)
2014 Hermitage Blanc (3)
2013 Hermitage Rouge (3)
2014 Hermitage Rouge (3)
In six-bottle original wooden cases
5163 12 bottles *per lot* HK\$12,000-18,000

We are exceptionally proud to bring this extremely rare collection of finest Mosel wines from Egon Müller and JJ Prüm (lots 5164-5190) to our Hong Kong saleroom. Very rare Eiswein from 1983 and amazing Beerenauslese 1993 are just some of the real treasures. All wines were bought direct after release from these two top quality wine producers and stored ever since in the owners' very cool cellar in Germany. By the generosity of the owner we were able to taste many wines from his cellar, all were in perfect condition.

JJ Prüm, Wehlener Sonnenuhr Eiswein 1983
Mosel
AP No. 23. Slightly damaged capsule. Slightly stained label. Perfect level
5164 1 bottle *per lot* HK\$20,000-30,000

Mixed 1985 JJ Prüm
Wehlener Sonnenuhr Auslese Goldkapsel
AP No. 1. One sign of seepage. Pristine labels. Levels: two perfect, one 2.5cms (3)
Wehlener Sonnenuhr Auslese
AP No. 36. Excellent appearance. Pristine labels. Perfect levels (3)
5165 6 bottles *per lot* HK\$9,000-12,000

JJ Prüm, Zeltinger Sonnenuhr Auslese 1988
Mosel
AP No. 14. Excellent appearance
5166 6 bottles *per lot* HK\$3,000-4,200

JJ Prüm, Wehlener Sonnenuhr Auslese Goldkapsel 1992
Mosel
AP No. 18. Ex Grosser Ring Auction 1993. One damaged capsule with sign of old seepage. Slightly marked and slightly damaged labels. Excellent levels
5167 6 bottles *per lot* HK\$11,000-14,000

Mixed 1994 JJ Prüm
Wehlener Sonnenuhr Auslese Long Goldkapsel
AP No. 11. Ex Grosser Ring Auction 1995 (1)
Wehlener Sonnenuhr Auslese
AP No. 10. Ex Grosser Ring Auction 1995 (1)
5168 2 bottles *per lot* HK\$2,800-3,800

JJ Prüm, Wehlener Sonnenuhr Auslese 1997
Mosel
AP No. 16. Signs of seepage. Two stained labels
5169 6 bottles *per lot* HK\$2,400-3,000

JJ Prüm, Wehlener Sonnenuhr Auslese Goldkapsel 1998
Mosel
AP No. 13. In six-bottle original cartons. Slightly bin-soiled labels
5170 12 bottles *per lot* HK\$13,000-19,000

JJ Prüm, Wehlener Sonnenuhr Auslese Goldkapsel 1999
Mosel
AP No. 24. In six-bottle original cartons
5171 12 bottles *per lot* HK\$17,000-22,000

Mixed 1976 Egon Müller & JJ Prüm
Egon Müller, Scharzhofberger Auslese
AP No. 33. Excellent appearance. Pristine labels. Levels: 0.5cm or better (3)
JJ Prüm, Wehlener Sonnenuhr Auslese Goldkapsel
AP No. 21. Corroded capsule. Slightly stained label. Excellent level (1)
5172 4 bottles *per lot* HK\$11,000-14,000

Mixed Egon Müller & JJ Prüm

1979 Egon Müller, Scharzhofberger Auslese

AP No. 27. One slightly raised cork. Pristine labels. Levels: two 0.5cm, one 1cm (3)

1983 JJ Prüm, Wehlener Sonnenuhr Auslese Goldkapsel

AP No. 9. Excellent appearance. Levels: 1cm or better (3)

5173 6 bottles per lot HK\$9,500-13,000

Mixed 1993 Egon Müller & JJ Prüm

Egon Müller, Scharzhofberger Auslese Goldkapsel

AP No. 24. Ex Grosser Ring Auction 1994. One corroded capsule. Levels: one 0.5cm, one 1cm, one 3cms (3)

JJ Prüm, Wehlener Sonnenuhr Auslese Goldkapsel

AP No. 17. Ex Grosser Ring Auction 1994. Excellent appearance and levels (3)

5174 6 bottles per lot HK\$11,000-15,000

Mixed 1975 Egon Müller

Scharzhofberger Auslese Goldkapsel

AP No. 58. Excellent appearance. Perfect level (1)

Scharzhofberger Auslese

AP No. 28. Slightly raised cork. Pristine label. Excellent level (1)

5175 2 bottles per lot HK\$5,000-8,000

Mixed 1989 Egon Müller

Scharzhofberger Auslese Goldkapsel

AP No. 40. Ex Grosser Ring Auction 1990. Slightly bin-soiled, slightly damaged label. Perfect level (1)

Scharzhofberger Auslese

AP No. 14 & 15. One damaged capsule. One bin-soiled and damaged label and one badly bin-soiled and damaged label. Perfect levels (2)

5176 3 bottles per lot HK\$9,000-12,000

Egon Müller, Scharzhofberger Auslese 1989

Mosel

AP No. 27. Ex Grosser Ring Auction 1990. Excellent appearance.

Levels: 0.5cm or better

5177 9 bottles per lot HK\$16,000-20,000

Mixed 1990 & 1991 Egon Müller

1990 Scharzhofberger Auslese

AP No. 30. One slightly stained label, otherwise pristine. Levels: one 0.5cm, one 1cm, one 1.5cms (3)

1991 Scharzhofberger Auslese Goldkapsel

AP No. 21. Ex Grosser Ring Auction 1992. Badly stained labels.

Excellent levels (3)

5178 6 bottles per lot HK\$13,000-17,000

Egon Müller, Scharzhofberger Beerenauslese 1990

Mosel

AP No. 2. Ex Grosser Ring Auction 1994. Very slightly stained label.

Excellent level of 1cm

5179 1 bottle per lot HK\$15,000-20,000

Egon Müller, Scharzhofberger Auslese 1991

Mosel

AP No. 19. Ex Grosser Ring Auction 1992. One sign of old seepage.

Levels: two 0.5cm, one 1cm, two 1.5cms, one 3.5cms

5180 6 bottles per lot HK\$9,000-12,000



Lot 5175



MOSEL-SAAR-RUWER
 RIESLING
 Product of Germany



1996
Scharzhofberger Eiswein
Egon Müller zu Scharzhof

Abgefüllt im
 Keller zu Scharzhof,
 D 54459 Wiltingen

Alc. 6% by vol. A.P.-Nr. 3 567 142-56-03 375 ml

SAAR-RUWER
 RIESLING
 Product of Germany



1996
Scharzhofberger Eiswein
Egon Müller zu Scharzhof

Abgefüllt im
 Keller zu Scharzhof,
 D 54459 Wiltingen

% by vol. A.P.-Nr. 3 567 142-56-03 375 ml

MOSEL-SAAR-RUWER
 RIESLING
 Product of Germany



1996
Scharzhofberger Eiswein
Egon Müller zu Scharzhof

Abgefüllt im
 Keller zu Scharzhof,
 D 54459 Wiltingen

Alc. 6% by vol. A.P.-Nr. 3 567 142-56-03

Mixed Formats of 1992 Egon Müller, Scharzhofberger Auslese Goldkapsel

1992

Slightly raised corks. One damaged capsule. Slightly stained labels. Perfect levels (3)

1992

Excellent appearance. Levels: 0.5cm or better half-bottles (3)
All ex Grosser Ring Auction 1993. AP No. 22

5181 3 bottles and 3 half-bottles *per lot* HK\$9,000-13,000

Egon Müller, Scharzhofberger Eiswein 1992

Mosel

AP No. 73. Sign of old seepage. Pristine label. Perfect level

5182 1 bottle *per lot* HK\$28,000-32,000

Mixed 1993 Egon Müller

Scharzhofberger Auslese Goldkapsel

AP No. 23. Excellent appearance (3)

Scharzhofberger Auslese

AP No. 21. Ex Grosser Ring Auction 1994. Excellent appearance (3)

5183 6 bottles *per lot* HK\$11,000-16,000

Egon Müller, Scharzhofberger Beerenauslese 1993

Mosel

AP No. 26. Ex Grosser Ring Auction 1997. Sign of old seepage.

Stained label. Perfect level

5184 1 bottle *per lot* HK\$11,000-13,000

Mixed 1994 Egon Müller

Scharzhofberger Auslese Goldkapsel

AP No. 20. Ex Grosser Ring Auction 1995. Excellent appearance and levels (3)

Scharzhofberger Auslese

AP No. 18. Ex Grosser Ring Auction 1995. One stained label. Levels: one 0.5cm, one 1cm, one 1.5cms (3)

5185 6 bottles *per lot* HK\$12,000-15,000

Egon Müller, Scharzhofberger Auslese 1995

Mosel

AP No. 20. Ex Grosser Ring Auction 1996. Three with signs of old seepage. One stained label. Excellent levels

5186 6 bottles *per lot* HK\$11,000-15,000

Egon Müller, Scharzhofberger Eiswein 1996

Mosel

AP No. 56. Signs of seepage. Excellent levels of 0.5cm or better

5187 3 half-bottles *per lot* HK\$18,000-24,000

Egon Müller, Scharzhofberger Auslese 1996

Mosel

AP No. 17. One corroded capsule. Three signs of old seepage. Levels: one 0.5cm, two 1cm, two 1.5cms, one 2cms

5188 6 bottles *per lot* HK\$5,500-8,500

Mixed 1997 Egon Müller

Scharzhofberger Auslese Goldkapsel

AP No. 23. Ex Grosser Ring Auction 1998. Corroded capsule (1)

Scharzhofberger Auslese

AP No. 21. Ex Grosser Ring Auction 1998. One sign of old seepage (2)

5189 3 bottles *per lot* HK\$5,500-7,000

Egon Müller, Scharzhofberger Auslese 1999

Mosel

AP No. 26. In original wooden case. Only vintage ever released in wood. Excellent appearance

5190 12 bottles *per lot* HK\$26,000-35,000



MERCI
1830

TERRANTEZ
1860

SEBO
1830

BUAL
1838

TERRANTEZ

111

ELLA
TOCK

30

RIDEL

1934

ANTIGO
ES
de Lobes
A

E N

MASTIA
VELHA

BUAL
1838

CAMPANARIO

VERDELE

1934

F E M

BUAL
1838

PANA



ERRANTEZ
1840

VERDELHO

BUAL
VELHO
1860

VERDELHO

MALVAS

1830

RES' LO

CUN

19
F E

BUAL
VELHO
1860

BOAL
1933

BUAL
VELHO
1860

BUAL
VELHO
1860

BUAL
VELHO
1860

BO
19

CUNHA

CAMPANARI

CUNHA

CUNHA

CUNHA

CAMPANARI

AN INCREDIBLE COLLECTION OF CENTURY OLD MADEIRA

The following lots 5191 to 5210 represent an incredible collection of liquid time capsules. All the bottles were reconditioned or bottled from old demi-johns and shipped directly from Madeira to HK for this sale. Christie's specialists have tasted and selected these Madeira for their very high quality.

Tasting Notes by Edwin Vos (EV), Director, Head of Wine Sales Continental Europe

MADEIRA

Madeira is the name of both the volcanic Portuguese island of the coast of North Africa, and the fortified wine made there. The four classic types of Madeira are named after the grapes from which they are made: Sercial, Verdelho, Bual and Malvasia. All four of these types of Madeira are still in production today and typically have high natural acidity.

Two other grape varieties, Terrantez and Bastardo are much rarer as they are very susceptible to disease and were almost wiped out by phylloxera and are only seen in voluminous and comprehensive Madeira collections like the one offered here today. The majority of Madeira, however, is made from a grape called tinta negra mole, or tinta. Technically, tinta is considered a "good variety" as opposed to a "noble" one and as such, none of the wines in this extraordinary collection contain that grape. Here, we are offering only the finest and noblest.

To make Madeira, fermentation of the grapes is usually stopped by the addition of alcohol. In the middle of the 18th Century brandy was first used to fortify and also stabilise the wine for shipment to England and her colonies. The wine can then be additionally sweetened, then undergoes estufa. Estufa, one of the most unique wine making processes in the world, came about quite by accident. Madeira was ideally located as a stopping point for ships destined for the East and West Indies. Since the majority of the Madeira was made for export, the wine often spent long periods of time ageing in casks being used as ballast in the holds of shipping vessels. When it was discovered that the slow heating of the wine had a positive effect, the merchants preferred that the wine cross the tropics twice in order for it to reach full maturity. This process of heat and controlled oxidation lead to the invention of the estufa system, currently in use, as a way of replicating these ocean voyages. In the estufagem, the fortified wine is heated to (by law) between 40 and 50 degrees Centigrade for a legal minimum of three months. After the wine has been heated it is cooled (special care being taken to ensure that the wine does not over-oxidize) and then placed in "pipes" for the resting period known as estagio for a year or more, after which it is stored in casks of a solera (much like sherry) or observed for potential as vintage Madeira.

Michael Broadbent writing in his book Vintage Wine stated that "Madeira has always been one of my favourite wines, and I am glad to say, vintage Madeira is making a comeback".

Torre Bella, Terrantez Private Stock 1801

Madeira

Rebottled in 2017. New wax capsule with original DB seal. New stencilling on old flute shape bottle. Level: into neck

5191 1 bottle *per lot* HK\$32,000-40,000

Torre Bella, Verdelho Private Stock 1811

Madeira

Bottled in 2017. New wax capsule with original FMA seal. New stencilling on old three part moulded bottle from begin of 20th century. Level: into neck

Tasting note: Strong deep nose of apple tackle and spice cake. Quite expressive. Clearly a long cask aged classic style Madeira. On the taste this sensation of extended canteiro aging continues. Balsamic aromas followed by concentrated acidity and sweet dried fruits linger on the after taste with a slight bitter tone behind. Strong wine. March 2018. EV.

5192 1 bottle *per lot* HK\$9,500-11,000

Torre Bella, Verdelho Private Stock 1811

Madeira

Bottled in 2017. New wax capsule with original FMA seal. New stencilling on old Burgundy shaped bottle. Level: 4cms

Tasting note: Strong deep nose of apple tackle and spice cake. Quite expressive. Clearly a long cask aged classic style Madeira. On the taste this sensation of extended canteiro aging continues. Balsamic aromas followed by concentrated acidity and sweet dried fruits linger on the after taste with a slight bitter tone behind. Strong wine. March 2018. EV.

5193 1 bottle *per lot* HK\$9,500-11,000

Cunha, Sercial 1830

Madeira

Rebottled in 2016 by FMA. New wax capsules with A Madeira seal. Stencilled bottles. Levels: into neck

Tasting note: High toned, straw and lemon fresh style of nose. Subdued backward still, touch of butter. Pure and youthful appearance. Good concentration.

Soft creamy taste start, buttery mouth feel, pure citrus fruit flavors followed by great finessed acidity. Lingered fresh finish of classic aged Sercial. Love this wine. Last tasted February 2016. EV.

5194 2 bottles *per lot* HK\$16,000-20,000

JCS Estreito, Pico e Salões, Câmara de Lobos, Verdelho Antigo 1830

Madeira

Rebottled in 2016. New wax capsule with A Madeira seal, slightly damaged. Badly bin-soiled and badly damaged label with vintage stencilling on the neck. Level: into neck

Tasting note: On the nose floral tones, quite attractive in fact. Finesse. Freshly crushed white peaches. Day after from different bottle more butterscotch, vintage wax, dried peaches, in a more closed way compared to the previous bottle. Clearly a long cask aged wine of high quality.

Fine creamy pure citrus taste, medium dry, lovely acidity. Well balanced. Very nice soft slightly sweet. Last tasted February 2016. EV.

5195 1 bottle *per lot* HK\$8,000-10,000

JCS Estreito, Pico e Salões, Câmara de Lobos, Verdelho Antigo 1830

Madeira

Rebottled in 2016. New wax capsules with A Madeira seals, slightly damaged. Remains of label only, badly bin-soiled. Vintage stencilled on the neck. Levels: into neck

Tasting note: On the nose floral tones, quite attractive in fact. Finesse. Freshly crushed white peaches. Day after from different bottle more butterscotch, vintage wax, dried peaches, in a more closed way compared to the previous bottle. Clearly a long cask aged wine of high quality.

Fine creamy pure citrus taste, medium dry, lovely acidity. Well balanced. Very nice soft slightly sweet. Last tasted February 2016. EV.

5196 2 bottles *per lot* HK\$16,000-20,000

Bual Campanario 1838*Madeira**Rebottled in 2018 by FMA. New wax capsules with FMA seal. New stencilling. Levels: into neck*

Tasting note: Concentrated Indian spices, Havana cigars, some vintage furniture wax, clearly an extremely long cask aged style. Touch of rosehip. Mouth filling rich with fine acidity on the back. Unctuous, banana style fruit, on the after taste a peacock's tail of sweetness flows out on the palette followed by concentrated acidity. Great taste, love this great wine. I have had this wine from two cellars on Madeira, both I regard highly, and it's always a pleasure to taste this wine. June 2017. EV.

5197 2 bottles *per lot* HK\$16,000-20,000
 5198 2 "

Perestrello, Terrantez 1840*Madeira**Bottled in 2016. New wax capsules with A Madeira seal. Stencilled bottle. Levels: into neck*

Tasting note: Clear golden yellow color. Fresh straw, lemons, spring flowers, touch of varnish and butter on the fine high toned nose. Quite on concentrated and on the butterscotch side. Very good nose. Old furniture wax. Fresh herbs. Soft well balanced start of taste, lemon zest, freshly sweet, on the finish fine buttery. Quite elegant, like bittersweets. Fine-tuned Terrantez of very good quality, especially the balance and finesse is remarkable. Vintage furniture wax with fine grapefruit bitters. Very good wine from a family whose descendants are directly related to the discovery of Madeira Island. February 2016. EV.

5199 2 bottles *per lot* HK\$20,000-30,000

Cunha, Bual Velho 1860*Madeira**Bottled in 2016 by GD. New wax capsule with A Madeira seal. New stencilling. Level: into neck*

Tasting note: Deep orange color. Sweet nose of raisins and Indian spices. Pure and rich. Lovely nose of fine complexity. Rounded fresh taste start followed by mouth filling rich peach fruit aromas, very nice intensity and youthful appearance. Quite sweet for a Bual with a lot of charm. Very good wine. June 2017. EV.

5200 1 bottle *per lot* HK\$5,000-6,000

Cunha, Bual Velho 1860*Madeira**Bottled in 2016 by GD. New wax capsules with A Madeira seal. New stencilling. Levels: into neck*

Tasting note: Deep orange color. Sweet nose of raisins and Indian spices. Pure and rich. Lovely nose of fine complexity. Rounded fresh taste start followed by mouth filling rich peach fruit aromas, very nice intensity and youthful appearance. Quite sweet for a Bual with a lot of charm. Very good wine. June 2017. EV.

5201 2 bottles *per lot* HK\$10,000-12,000
 5202 2 "
 5203 2 "

Torre Bella, Terrantez 1860*Madeira**Bottled in 2018 by GD. New wax capsule with FMA seal. New stencilling. Level: into neck*

Tasting note: Direct expressive nose with green banana leaf aromas, some tobacco and honey, quite perfumed and uplifted. Softly sweet taste of exotic fruit richness with some banana leafy green tone to it. On the finish quite focused and well defined. Love the acidity and typical tobacco character to this. Very good length of taste. Very good. Getting better with air, and time. Elegant. June 2017. EV.

5204 1 bottle *per lot* HK\$8,000-10,000

Boal Campanario 1933*Madeira**Bottled in 2015 by FMA. New wax capsules with A Madeira seal. Stencilled bottle. Levels: into neck*

5205 2 bottles *per lot* HK\$4,000-6,000
 5206 2 "

FEM, Verdelho 1934*Madeira**From family of Francisco Albuquerque. Bottled in 2015 by FMA. New wax capsules with A Madeira seal. Stencilled bottle. Levels: into neck*

5207 2 bottles *per lot* HK\$4,000-6,000
 5208 2 "

Malvasia M Velha Believed 1893*Madeira**Recorded in 2016 by FMA. New wax capsules over old JNV wax seal with FMA seal on top. Fading stencilling. Levels: into neck*

Tasting note: Deep dark flavored nose of concentrated cask aged aromas, with some air more sweet raisiny flavors appeared. Full flavoured sweet taste of character and length. The lingering sweetness balanced by the fine acidity is of great class. What a wine. Fresh and intense at same time. Great wine. Last tasted June 2017. EV.

5209 2 bottles *per lot* HK\$8,000-10,000
 5210 2 "

FINEST & RAREST BORDEAUX, BURGUNDY FROM AN EXCEPTIONAL PRIVATE COLLECTION

We are privileged to be able to offer the following lots 5211 to 5263 that are part of a superb private collection of many of the finest wines from France. The collection encompasses the finest vintages of the last seven decades from the most prestigious producers from Bordeaux and Burgundy. 1945, 1986, & 2000 vintages are represented from the Left and Right Bank. Superlative 1978, 1988, 1999 & 2005 vintages of legendary wines from Burgundy are also offered.

The wines were stored in impeccable temperature and humidity controlled professional storage prior to shipment specifically for the sale. The wines were inspected in situ and once again in Hong Kong by Christie's Specialists and the conditions are excellent. The wines were purchased from reputable sources and auction houses.

Château Lafite-Rothschild 1986
Pauillac, 1er cru classé
Excellent appearance. Levels: into neck
 5211 6 bottles *per lot* HK\$38,000-55,000

Château Margaux 1990
Margaux, 1er cru classé
Excellent appearance. Levels: base of neck or better
 5214 6 bottles *per lot* HK\$32,000-48,000

Château Mouton-Rothschild 1945
Pauillac, 1er cru classé
Slightly damaged Château-embossed capsule. Damaged US import label. Slightly bin-soiled two part label. Level: mid-upper-shoulder
 5212 1 bottle *per lot* HK\$60,000-90,000

Petrus 1989
Pomerol, cru exceptionnel
Badly stained and damaged labels. Four with remains of labels only.
Levels: into neck
 5215 6 bottles *per lot* HK\$140,000-200,000

Château Mouton-Rothschild 1945
Pauillac, 1er cru classé
Excellent appearance. Original tissues. Recent Château release.
One part R.C. labels. One very slightly stained label. BBR Japanese import back labels. Levels: into neck
 5213 6 bottles *per lot* HK\$450,000-700,000

Petrus 1989
Pomerol, cru exceptionnel
In original wooden case. Integrated US import front labels. Excellent appearance. Levels: eleven base of neck or better, one top-shoulder
 5216 12 bottles *per lot* HK\$280,000-420,000



Lot 5213

Petrus 1989

*Pomerol, cru exceptionnel
In original wooden case. Integrated US import front labels. One
corroded and damaged, three slightly damaged capsules. One very
slightly damaged label. Levels: eleven base of neck or better, one
top-shoulder*

5217 12 bottles per lot HK\$280,000-420,000

Petrus 1990

*Pomerol, cru exceptionnel
Very slightly damaged labels. Levels: into neck*

5218 6 bottles per lot HK\$140,000-200,000

Petrus 1990

*Pomerol, cru exceptionnel
In original wooden case. Integrated US import front labels.
US import back labels. Three slightly damaged capsules. One very
slightly stained label. Levels: base of neck or better*

5219 12 bottles per lot HK\$280,000-420,000

Petrus 2000

*Pomerol, cru exceptionnel
In single original wooden cases. Excellent appearance. Levels: into
neck*

5220 1 magnum per lot HK\$55,000-85,000

5221 1 "

Petrus 2000

*Pomerol, cru exceptionnel
Excellent appearance. Levels: base of neck or better*

5222 6 bottles per lot HK\$160,000-220,000

Le Pin 1989

*Pomerol
In original wooden case. BBR Japanese import back labels. Glue-
stained labels. Levels: ten base of neck or better and two top-
shoulder*

5223 12 bottles per lot HK\$190,000-280,000

Le Pin 1990

*Pomerol
In original wooden case. BBR Japanese import back labels. Four very
slightly stained labels. Levels: base of neck or better*

5224 12 bottles per lot HK\$280,000-420,000



Lot 5216



Lot 5224

Domaine de la Romanée-Conti, Montrachet 1997*Grand Cru, Côte de Beaune**In original wooden case. Swiss import back labels. Bottle colour variation, four slightly darker coloured. Three slightly raised corks.**Levels: one 2cms, one 2.5cms, one 3cms, two 3.5cms, one 4cms*5225 6 bottles *per lot HK\$190,000-280,000***Domaine de la Romanée-Conti, Montrachet 1999***Grand Cru, Côte de Beaune**Lot 5226: Swiss import back labels. Excellent appearance. Levels: 1cm**Lot 5227: Swiss import back labels. Excellent appearance. Levels: one 1.5cms, one 2cms, one 2.5cms*5226 3 bottles *per lot HK\$110,000-160,000*

5227 3 "

Domaine de la Romanée-Conti, Montrachet 2000*Grand Cru, Côte de Beaune**In original wooden case. Original straws. Swiss import back labels.**One very slightly stained label, otherwise excellent appearance.**Levels: five 2.5cms and one 3cms*5228 6 bottles *per lot HK\$220,000-320,000***Domaine de la Romanée-Conti, Montrachet 2002***Grand Cru, Côte de Beaune**Swiss import back label. Excellent appearance. Level: 0.5cm*5229 1 bottle *per lot HK\$45,000-65,000***Domaine de la Romanée-Conti, Montrachet 2004***Grand Cru, Côte de Beaune**Corroded and slightly damaged capsule. Good appearance. Wilson Daniels import back label. Level: 4.5cms*5230 1 magnum *per lot HK\$75,000-110,000***Domaine de la Romanée-Conti, Romanée-Conti 1978***Grand Cru, Côte de Nuits**Lot 5231: Very slightly damaged capsule. Leroy slip label. Very slightly stained label. BBR Japanese import back label. Level: 4cms**Lot 5232: Very slightly damaged capsule. Leroy slip label. Very slightly stained label. BBR Japanese import back label. Level: 4.5cms*5231 1 bottle *per lot HK\$110,000-170,000*

5232 1 "

Domaine de la Romanée-Conti, Romanée-Conti 1990*Grand Cru, Côte de Nuits**Wilson Daniels import back label. Good appearance. Level: 1.5cms*5233 1 bottle *per lot HK\$120,000-180,000***Domaine de la Romanée-Conti, Romanée-Conti 1999***Grand Cru, Côte de Nuits**In three-bottle original wooden cases. Swiss import back labels.**Excellent appearance. Levels: 0.5cm or better*5234 6 bottles *per lot HK\$700,000-1,100,000***Domaine de la Romanée-Conti, Romanée-Conti 2003***Grand Cru, Côte de Nuits**Damaged German import back label. Japanese BBR import label.**Capsule marked label. Level: 0.5cm*5235 1 bottle *per lot HK\$100,000-150,000***Domaine de la Romanée-Conti, Romanée-Conti 2003***Grand Cru, Côte de Nuits**In original wooden case. Corney & Barrow import back labels.**Excellent appearance and high fill levels*5236 3 bottles *per lot HK\$280,000-450,000*

Lot 5226



ROMANÉE-CONTI

MONOPOLE
1999

SOCIÉTÉ CIVILE DU DOMAINE DE LA ROMANÉE-CONTI
PROPRIÉTAIRE A VOSNE-ROMANÉE (COTE-D'OR) FRANCE

ROMANÉE-CONTI

APPELLATION ROMANÉE-CONTI CONTRÔLÉE

6.917 Bouteilles Récoltées

BOUTEILLE N° 02239
ANNÉE 1999

LES ASSOCIÉS-GÉRANTS

Henri-Frédéric Roch
A. d. V. & C. S.A.

Mise en bouteille au domaine

Lot 5234

Domaine de la Romanée-Conti, La Tâche 2002

Grand Cru, Côte de Nuits

Swiss import back labels. Excellent appearance. Levels: one 1.5cms and one 2cms

5237 2 magnums per lot HK\$120,000-180,000

Domaine de la Romanée-Conti, La Tâche 2003

Grand Cru, Côte de Nuits

One very slightly stained label otherwise excellent appearance.

Wilson Daniles import back labels. Levels: one 1.5cms and one 2cms

5238 2 magnums per lot HK\$110,000-160,000

Domaine de la Romanée-Conti, La Tâche 2003

Grand Cru, Côte de Nuits

In original wooden case. Original straws. Consecutive bottle numbers. Dutch import back labels. Excellent appearance. Levels: 1cm or better

5239 6 bottles per lot HK\$150,000-220,000

Domaine de la Romanée-Conti, Romanée-Saint-Vivant 1988

Grand Cru, Côte de Nuits

Green roundels on labels. One stained label. Levels: one 1.5cms and one 3cms

5240 2 bottles per lot HK\$20,000-30,000

Domaine d'Auvenay, Chevalier-Montrachet 2003

Grand Cru, Côte de Beaune

Japanese import back labels. Very slightly damaged wax capsules. Signs of old seepage. Excellent appearance. Levels: 3cms and 3.5cms

5241 2 bottles per lot HK\$50,000-75,000

Domaine d'Auvenay, Criots-Bâtard-Montrachet 2002

Grand Cru, Côte de Beaune

Japanese import back labels. Excellent appearance. Levels: 1.5cms or better

5242 2 bottles per lot HK\$65,000-95,000

Domaine d'Auvenay, Criots-Bâtard-Montrachet 2004

Grand Cru, Côte de Beaune

Japanese import back labels. One slightly damaged wax capsule. Excellent appearance. Levels: 2cms or better

5243 3 bottles per lot HK\$110,000-170,000

Domaine d'Auvenay, Mazis-Chambertin 2000

Grand Cru, Côte de Nuits

In Leroy presentation carton. Japanese import back label. Stained label. Level: 1.5cms

5244 1 bottle per lot HK\$24,000-35,000

Domaine d'Auvenay, Mazis-Chambertin 2000

Grand Cru, Côte de Nuits

Japanese import back labels. Stained labels. Levels: two 1.5cms and one 2cms

5245 3 bottles per lot HK\$60,000-90,000

Domaine d'Auvenay, Mazis-Chambertin 2001

Grand Cru, Côte de Nuits

Japanese import back labels. Slightly stained labels. Levels: 1cm or better

5246 3 bottles per lot HK\$75,000-110,000

Domaine d'Auvenay, Bonnes-Mares 2000

Grand Cru, Côte de Nuits

In Leroy presentation carton. Japanese import back label. Stained label. Level: 1.5cms

5247 1 bottle per lot HK\$22,000-35,000

Domaine d'Auvenay, Bonnes-Mares 2000

Grand Cru, Côte de Nuits

Japanese import back labels. Slightly stained labels. Levels: 1.5cms

5248 3 bottles per lot HK\$60,000-90,000



Lot 5243

Domaine d'Auvenay, Bonnes-Mares 2001

Grand Cru, Côte de Nuits

Japanese import back labels. Stained and very slightly damaged labels. Levels: two 1cm and one 2.5cms

5249 3 bottles per lot HK\$65,000-100,000

Domaine Leroy, Chambertin 2006

Grand Cru, Côte de Nuits

In six-bottle Leroy wooden presentation case, with wine stain inside the case. Japanese import back labels. Signs of seepage. Excellent appearance. Levels: 1cm or better

5250 3 bottles per lot HK\$110,000-170,000

Domaine Leroy, Chambertin 2007

Grand Cru, Côte de Nuits

Japanese import back labels. Signs of active seepage. Slightly damaged wax capsules. Very slightly damaged labels. Levels: one 2cms, one 2.5cms and one 3cms

5251 3 bottles per lot HK\$70,000-120,000

Domaine Leroy, Chambertin 2008

Grand Cru, Côte de Nuits

In three-bottle Leroy presentation carton. Very slightly damaged wax capsules. Japanese import back labels. Excellent appearance. Levels: one 1.5cms and one 2cms

5252 2 bottles per lot HK\$75,000-110,000

Domaine Leroy, Chambertin 2009

Grand Cru, Côte de Nuits

In single Leroy presentation cartons. Japanese import back labels. Signs of old seepage. One very slightly damaged label. Levels: 2.5cms

5253 2 bottles per lot HK\$90,000-130,000

Domaine Leroy, Clos de la Roche 1996

Grand Cru, Côte de Nuits

US import slip labels. Red metal capsules. Excellent appearance. Levels: one 1cm, three 1.5cms and two 2cms

5254 6 bottles per lot HK\$110,000-170,000

Domaine Leroy, Musigny 2007

Grand Cru, Côte de Nuits

In Leroy presentation carton. Japanese import back label. Sign of old seepage. Level: 2.5cms

5255 1 bottle per lot HK\$60,000-90,000

Domaine Leroy, Musigny 2008

Grand Cru, Côte de Nuits

Very slightly damaged wax capsule. Japanese import back label. Excellent appearance. Level: 1cm

5256 1 bottle per lot HK\$60,000-95,000

Domaine Leroy, Musigny 2009

Grand Cru, Côte de Nuits

In Leroy presentation carton. Sign of old seepage. Japanese import back label. Excellent appearance. Level: 1.5cms

5257 1 bottle per lot HK\$90,000-130,000

Domaine Leroy, Richebourg 2008

Grand Cru, Côte de Nuits

In three-bottle Leroy presentation carton. Japanese import back labels. Excellent appearance. Levels: 1.5cms

5258 2 bottles per lot HK\$42,000-65,000

Domaine Leroy, Richebourg 2009

Grand Cru, Côte de Nuits

In single Leroy presentation cartons. Japanese import back labels. Signs of old seepage. Levels: one 1.5cms and one 2cms

5259 2 bottles per lot HK\$65,000-95,000

Domaine Leroy, Romanée-Saint-Vivant 2008

Grand Cru, Côte de Nuits

Japanese import back label. Excellent appearance. Level: 1cm

5260 1 bottle per lot HK\$22,000-32,000



Maison Leroy, Meursault-Blagny Premier Cru 1999*1er, Côte de Nuits**Excellent appearance. Levels: 0.5cm or better*5261 3 bottles *per lot* HK\$9,000-14,000**Domaine Comte Georges de Vogüé, Musigny Vieilles Vignes 2002***Grand Cru, Côte de Nuits**In original wooden case. Integrated US import front labels and US import back labels. Excellent appearance. Levels: 1cm or better*5262 6 bottles *per lot* HK\$30,000-45,000**Domaine Comte Georges de Vogüé, Musigny Vieilles Vignes 2005***Grand Cru, Côte de Nuits**One very slightly damaged label, otherwise excellent appearance. Integrated US import front labels and US import back labels. Levels: 0.5cm or better*5263 5 bottles *per lot* HK\$32,000-50,000**AN EXCEPTIONAL EUROPEAN COLLECTION**

We are very proud to be able to offer you this selection of wines from one of the finest collections in Europe (lots 5264-5276). A breathtaking line-up of finest Bordeaux, Burgundy and Italy. All shipped directly after release from the producer's cellar to the owner's temperature controlled storage in Continental Europe.

The collection features many classic great wines such as 1988 Haut-Brion, 2002 de Vogue Musigny and 1998 Sassicaia.

Château Haut-Brion 1988*Pessac (Graves), 1er cru classé**In original wooden case. Slightly corroded capsule. Excellent appearance. Level: into neck*5264 1 imperial *per lot* HK\$28,000-35,000**Château Haut-Brion 2000***Pessac (Graves), 1er cru classé**In original wooden case*5265 1 imperial *per lot* HK\$42,000-50,000**Château d'Yquem 1986***Sauternes, 1er grand cru classé**In original wooden case. Excellent appearance. Pristine labels.**Levels: six base of neck, six very top-shoulder*5266 12 bottles *per lot* HK\$24,000-32,000**Domaine Armand Rousseau, Chambertin-Clos de Bèze 2010***Grand Cru, Côte de Nuits**In original carton*5267 6 bottles *per lot* HK\$80,000-110,000**Mixed Domaine Armand Rousseau, Clos Saint Jacques in Magnums****2009**

magnum (1)

2010

magnum (1)

2011

magnum (1)

5268 3 magnums *per lot* HK\$40,000-55,000**Domaine Comte Georges de Vogüé, Bonnes-Mares 2002***Grand Cru, Côte de Nuits**In original wooden case*5269 1 magnum *per lot* HK\$9,000-12,000**Domaine Comte Georges de Vogüé, Musigny Vieilles Vignes 2002***Grand Cru, Côte de Nuits**In original wooden case*5270 1 magnum *per lot* HK\$16,000-24,000**Sassicaia 1998***Tuscany**In banded six-bottle original wooden cases*5271 12 bottles *per lot* HK\$16,000-24,000

5272 12 "

Sassicaia 2001*Tuscany**In six-bottle original wooden cases*5273 12 bottles *per lot* HK\$18,000-24,000

5274 12 "

Gaja, Ca' Marcanda, Camarcanda 2007*Tuscany**In six-bottle original wooden cases*5275 12 bottles *per lot* HK\$11,000-16,000**J.J. Prüm 2005 Auslese & Goldkapsel****Wehlener Sonnenuhr Auslese Goldkapsel**

(6)

Wehlener Sonnenuhr Auslese

(6)

*In six-bottle original cartons*5276 12 bottles *per lot* HK\$6,500-8,500

The following lots 5277 to 5283 include the prestige wines of Burgundy from Domaine de la Romanée-Conti and Domaine Leroy.

Domaine de la Romanée-Conti, La Tâche 1989*Grand Cru, Côte de Nuits**Badly stained label. Damaged back label. Level: 2.2cms*5277 1 bottle *per lot* HK\$20,000-30,000

Domaine de la Romanée-Conti, Richebourg 1991*Grand Cru, Côte de Nuits**Damaged and slightly stained label. Slightly damaged Malaysian import back label. Level: 2.5cms*5278 1 bottle *per lot* HK\$20,000-30,000**Domaine de la Romanée-Conti, Richebourg 1992***Grand Cru, Côte de Nuits**Stained and slightly damaged label. Stained Malaysian import back label with Singaporean slip label on top. Level: 2.2cms*5279 1 bottle *per lot* HK\$12,000-18,000**Domaine de la Romanée-Conti, Romanée-Saint-Vivant 1991***Grand Cru, Côte de Nuits**Sign of old seepage. Damaged label. Stained and slightly damaged Malaysian import back label. Level: 1.8cms*5280 1 bottle *per lot* HK\$15,000-22,000**Domaine Leroy, Vosne-Romanée Les Beaux Monts 1989***1er Cru, Côte de Nuits**Worn capsules. One stained and badly damaged vintage neck label. Stained and slightly damaged front and back labels. Levels: one 0.8cm, one 1cm*5281 2 bottles *per lot* HK\$19,000-28,000**Domaine Leroy, Vosne-Romanée Les Beaux Monts 1996***1er Cru, Côte de Nuits**Worn capsule. Detached vintage neck label, reattached by tape. Slightly stained and slightly damaged front and back labels. Level: 1.5cms*5282 1 bottle *per lot* HK\$11,000-17,000**Mixed Domaine Leroy****1992 Clos de la Roche***Worn capsule. Slightly stained vintage neck labels, front and back labels. Level: 1cm* (1)**2005 Pommard Les Vignots***Slightly damaged wax capsule. Stained and damaged front label. Slightly damaged and stained back label* (1)5283 2 bottles *per lot* HK\$16,000-24,000**OUTSTANDING VINTAGES OF BORDEAUX FROM A PRIVATE COLLECTOR**

The following lots 5284 to 5331 of superb vintages of Bordeaux belong to a private collector who is delighted to be sharing a part of her collection of vinous treasures. The collection features exceptional vintages from the world's premiere producers of Bordeaux.

Salon Le Mesnil Blanc de Blancs 2002*Le Mesnil-sur-Oger**In three-bottle original wooden cases*5284 6 bottles *per lot* HK\$20,000-30,000**Château Cos d'Estournel 1989***Saint-Estéphe, 2ème cru classé**In six-bottle original wooden cases. Very slightly stained labels. Levels: base of neck or better*5285 12 bottles *per lot* HK\$11,000-17,000**Château Cos d'Estournel 2001***Saint-Estéphe, 2ème cru classé**In original wooden case with slightly damaged lid*5286 12 bottles *per lot* HK\$9,500-15,000**Château Montrose 2010***Saint-Estéphe, 2ème cru classé**In six-bottle original wooden cases*5287 12 bottles *per lot* HK\$14,000-20,000**Château Montrose 2016***Saint-Estéphe, 2ème cru classé**In six-bottle original wooden cases*5288 12 bottles *per lot* HK\$12,000-17,000**Château Lafite-Rothschild 2009***Pauillac, 1er cru classé**In banded six-bottle original wooden cases*5289 12 bottles *per lot* HK\$60,000-90,000**Château Lafite-Rothschild 2010***Pauillac, 1er cru classé**In banded six-bottle original wooden cases*5290 12 bottles *per lot* HK\$55,000-85,000**Château Lafite-Rothschild 2011***Pauillac, 1er cru classé**In banded six-bottle original wooden cases*5291 12 bottles *per lot* HK\$40,000-60,000**Château Mouton-Rothschild 2009***Pauillac, 1er cru classé**In banded six-bottle original wooden cases*5292 12 bottles *per lot* HK\$45,000-65,000**Château Mouton-Rothschild 2010***Pauillac, 1er cru classé**In banded six-bottle original wooden cases*5293 12 bottles *per lot* HK\$48,000-75,000

Château Mouton-Rothschild 2011
Pauillac, 1er cru classé
In banded six-bottle original wooden cases
5294 12 bottles *per lot* HK\$26,000-40,000
5295 12 "

Château Latour 2000
Pauillac, 1er cru classé
In banded six-bottle original wooden cases
5296 12 bottles *per lot* HK\$60,000-90,000

Château Latour 2010
Pauillac, 1er cru classé
In original wooden case
5297 6 bottles *per lot* HK\$40,000-60,000

Les Forts de Latour 2009
Pauillac, Chateau Latour
In six-bottle original wooden cases
5298 18 bottles *per lot* HK\$24,000-35,000

Château Pichon-Longueville, Lalande 1995
Pauillac, 2ème cru classé
In original wooden case
5299 12 bottles *per lot* HK\$14,000-22,000

Château Ducru-Beaucaillou 2016
Saint-Julien, 2ème cru classé
In six-bottle original wooden cases
5300 12 bottles *per lot* HK\$12,000-17,000

Château Léoville-Poyferré 2003
Saint-Julien, 2ème cru classé
In original wooden case
5301 12 bottles *per lot* HK\$9,500-15,000

Pavillon Blanc du Château Margaux 2016
Margaux
In banded six-bottle original wooden cases
5302 12 bottles *per lot* HK\$15,000-22,000

Château Margaux 2009
Margaux, 1er cru classé
In banded six-bottle original wooden cases
5303 12 bottles *per lot* HK\$48,000-75,000
5304 12 "

Château Margaux 2010
Margaux, 1er cru classé
In banded six-bottle original wooden cases
5305 12 bottles *per lot* HK\$48,000-75,000

Château Margaux 2011
Margaux, 1er cru classé
In banded six-bottle original wooden cases
5306 12 bottles *per lot* HK\$30,000-45,000

Château Palmer 1998
Cantenac (Margaux), 3ème cru classé
In original wooden case
5307 12 bottles *per lot* HK\$16,000-24,000

Château Haut-Brion 2010
Pessac (Graves), 1er cru classé
In six-bottle original wooden case
5308 6 bottles *per lot* HK\$26,000-40,000

Château Haut-Brion 2010
Pessac (Graves), 1er cru classé
In six-bottle original wooden cases
5309 12 bottles *per lot* HK\$50,000-80,000

Château La Mission-Haut-Brion 2008
Pessac (Graves), cru classé
In original wooden case
5310 6 bottles *per lot* HK\$7,500-11,000

Château Trotanoy 2000
Pomerol
In six-bottle original wooden cases
5311 12 bottles *per lot* HK\$16,000-24,000

Vieux-Château-Certan 2006
Pomerol
In original wooden cases
5312 12 bottles *per lot* HK\$12,000-19,000
5313 12 "

Château Cheval-Blanc 1999
Saint-Émilion, 1er grand cru classé (A)
In original wooden case
5314 12 bottles *per lot* HK\$32,000-48,000

Château Cheval-Blanc 2001

*Saint-Émilion, 1er grand cru classé (A)
In original wooden case*

5315 12 bottles *per lot* HK\$32,000-48,000

Chateau Angelus 2010

*Saint-Émilion, 1er grand cru classé
In banded six-bottle original wooden cases*

5316 12 bottles *per lot* HK\$26,000-40,000

5317 12 "

Château Ausone 2010

*Saint-Émilion, 1er grand cru classé (A)
In original wooden case*

5318 3 bottles *per lot* HK\$13,000-19,000

"Y" Château d'Yquem 2016

*Sauternes
In individual original wooden cases*

5319 2 magnums *per lot* HK\$3,200-4,800

Domaine de la Romanée-Conti, Bourgogne Hautes Côtes de Nuits Blanc 2011

Burgundy

5320 6 bottles *per lot* HK\$22,000-35,000

Domaine Bouchard Père & Fils, Montrachet 2009

*Grand Cru, Côte de Beaune
In six-bottle original wooden cases*

5321 12 bottles *per lot* HK\$38,000-55,000

Domaine Bouchard Père & Fils, Corton-Charlemagne 2015

*Grand Cru, Côte de Beaune
In individual original wooden cases*

5322 3 bottles *per lot* HK\$2,800-4,200

Joseph Drouhin, Beaune Clos des Mouches Blanc 2009

*1er Cru, Côte de Beaune
In original wooden case with slightly damaged lid*

5323 12 bottles *per lot* HK\$10,000-15,000



Lot 5320

Mixed Joseph Drouhin, Marquis de Laguiche Montrachet

2006 (1)
2008

Four slightly stained and one badly stained labels. Slightly stained back labels (5)

5324 6 bottles *per lot* HK\$20,000-30,000

Domaine Faiveley, Clos Saint-Denis 2015

Grand Cru, Côte de Nuits

In original wooden case

5325 6 bottles *per lot* HK\$5,500-8,500

Domaine Faiveley, Mazis-Chambertin 2009

Grand Cru, Côte de Nuits

In six-bottle original wooden cases

5326 18 bottles *per lot* HK\$20,000-30,000

Domaine Prieuré Roch, Chambertin-Clos de Bèze 2014

Grand Cru, Côte de Nuits

In six-bottle original wooden cases

5327 12 bottles *per lot* HK\$100,000-150,000

Domaine Prieuré Roch, Clos de Vougeot 2014

Grand Cru, Côte de Nuits

In six-bottle original wooden cases

5328 12 bottles *per lot* HK\$35,000-50,000

Domaine Prieuré Roch, Vosne-Romanée Les Suchots 2014

1er Cru, Côte de Nuits

In six-bottle original wooden cases

5329 12 bottles *per lot* HK\$32,000-48,000

Sassicaia 2015

Tuscany, Marchese Incisa della Rocchetta

In banded six-bottle original wooden cases

5330 12 bottles *per lot* HK\$20,000-30,000

Vega Sicilia Unico 2007

Ribera del Duero

In original wooden case

5331 3 bottles *per lot* HK\$5,500-8,000



A PRESTIGIOUS COLLECTION OF FINEST & RAREST WINES FROM THE WORLD'S PRESTIGIOUS ESTATE

This single-owner private collection (lots 5332-5391) features only the very finest & rarest wines from the world's best Estates: Domaine Leroy. This private collector has curated an exceptional collection of outstanding wines, rarely have I seen such a well-constructed collection. Highlights include a case of Corton-Charlemagne 2011; Clos de Vougeot from vintages 1989 to 2011 and Richebourg from the 1992 vintage. The wines are in excellent condition which is testament to the ideal temperature and humidity-controlled conditions in professional storage where the wines were stored and the exemplary provenance.

Domaine Leroy, Corton-Charlemagne 2011

Grand Cru, Côte de Beaune

One slightly damaged wax capsule. Taiwanese import slip labels

5332 3 bottles *per lot* HK\$55,000-85,000

Domaine Leroy, Corton-Charlemagne 2011

Grand Cru, Côte de Beaune

In Leroy original wooden case. Consecutive bottle numbers.

One very slightly stained and one very slightly damaged labels.

Taiwanese import slip labels

5333 12 bottles *per lot* HK\$220,000-350,000

Domaine Leroy, Bourgogne Aligoté 2011

Bourgogne

One sign of old seepage. Taiwanese import slip labels

5334 6 bottles *per lot* HK\$3,500-5,000

Domaine Leroy, Corton-Renards 2007

Grand Cru, Côte de Beaune

Damaged wax capsule and label. Taiwanese import slip label. Level: 2cms

5335 1 bottle *per lot* HK\$13,000-19,000

Domaine Leroy, Corton-Renards 2008

Grand Cru, Côte de Beaune

Slightly stained front and back labels. Taiwanese import slip label

5336 1 bottle *per lot* HK\$9,500-11,000

Domaine Leroy, Corton-Renards 2008

Grand Cru, Côte de Beaune

In twelve-bottle Leroy original wooden case. Signs of old seepage.

Taiwanese import slip labels. Levels: one 1cm, two 1.5cms, two 2cms, two 2.6cms

5337 7 bottles *per lot* HK\$75,000-100,000

Domaine Leroy, Corton-Renards 2011

Grand Cru, Côte de Beaune

Taiwanese import slip label

5338 1 bottle *per lot* HK\$13,000-19,000



Domaine Leroy, Volnay Santenots du Milieu 2011
1er Cru, Côte de Beaune
Sign of old seepage. Taiwanese import slip label
5339 1 bottle per lot HK\$5,500-7,500

Domaine Leroy, Savigny-lès-Beaune Les Narbantons 2011
1er Cru, Côte de Beaune
Taiwanese import slip labels
5340 3 bottles per lot HK\$16,000-24,000

Domaine Leroy, Pommard Les Vignots 2011
Côte de Beaune
Taiwanese import slip labels
5341 3 bottles per lot HK\$16,000-20,000

Domaine Leroy, Chambertin 2011
Grand Cru, Côte de Nuits
Taiwanese import slip label
5342 1 bottle per lot HK\$50,000-70,000

Domaine Leroy, Clos de Vougeot 1989
Grand Cru, Côte de Nuits
Badly worn capsule. Slightly stained label. Damaged vintage neck label. Damaged Taiwanese import slip label. Level: 1.8cms
5343 1 bottle per lot HK\$12,000-15,000

Domaine Leroy, Clos de Vougeot 1990
Grand Cru, Côte de Nuits
Sign of old seepage. One stained vintage neck label and back label. US and Taiwanese import slip labels. Levels: one 1cm and one 2cms
5344 2 bottles per lot HK\$30,000-45,000

Domaine Leroy, Clos de Vougeot 1997
Grand Cru, Côte de Nuits
Slightly depressed corks. Very slightly stained labels. Taiwanese import slip labels. Levels: one 1.2cms, one 1.7cms and one 2cms
5345 3 bottles per lot HK\$32,000-50,000

Domaine Leroy, Clos de Vougeot 1998
Grand Cru, Côte de Nuits
Slightly depressed cork. Taiwanese import slip label. Level: 1.2cms
5346 1 bottle per lot HK\$10,000-15,000

Domaine Leroy, Clos de Vougeot 1999
Grand Cru, Côte de Nuits
Slightly depressed cork. Slightly damaged back label. Taiwanese import slip label. Level: 1.5cms
5347 1 bottle per lot HK\$15,000-22,000

Domaine Leroy, Clos de Vougeot 2001
Grand Cru, Côte de Nuits
In Leroy original wooden case. Slightly damaged wax capsules. Signs of old seepage. One slightly damaged back label otherwise excellent appearance. Levels: one 0.5cm, two 1.5cms, five 2cms, four 2.5cms
5348 12 bottles per lot HK\$150,000-220,000

Domaine Leroy, Clos de Vougeot 2002
Grand Cru, Côte de Nuits
Sign of old seepage. Very slightly stained label. Taiwanese import back label. Level: 2.2cms
5349 1 bottle per lot HK\$13,000-19,000

Domaine Leroy, Clos de Vougeot 2008
Grand Cru, Côte de Nuits
One very slightly stained back labels. Taiwanese import slip labels
5350 3 bottles per lot HK\$35,000-55,000

Domaine Leroy, Clos de Vougeot 2009
Grand Cru, Côte de Nuits
Slightly damaged wax capsule. Sign of old seepage. Very slightly stained label. Level: 2.5cms
5351 1 bottle per lot HK\$15,000-20,000

Domaine Leroy, Clos de Vougeot 2010
Grand Cru, Côte de Nuits
Taiwanese import slip labels. Levels: 1.2cms
5352 2 bottles per lot HK\$28,000-45,000

Domaine Leroy, Clos de Vougeot 2011
Grand Cru, Côte de Nuits
In Leroy original wooden case. Consecutive bottle numbers.
Taiwanese import slip labels
5353 12 bottles per lot HK\$170,000-260,000

5354 No lot

Domaine Leroy, Clos de la Roche 1999
Grand Cru, Côte de Nuits
One creased capsule. Slightly depressed corks. Slightly stained
labels. Taiwanese import slip labels. Levels: two 1cm and one 1.5cms
5355 3 bottles per lot HK\$55,000-85,000

Domaine Leroy, Clos de la Roche 2011
Grand Cru, Côte de Nuits
Taiwanese import slip labels
5356 2 bottles per lot HK\$26,000-38,000

Domaine Leroy, Latricières-Chambertin 1997
Grand Cru, Côte de Nuits
Creased capsules. Very slightly stained labels. Taiwanese import
slip labels. Levels: one 2cms and two 2.5cms
5357 3 bottles per lot HK\$38,000-55,000

Domaine Leroy, Latricières-Chambertin 1999
Grand Cru, Côte de Nuits
Slightly depressed corks. One stained vintage neck label. Taiwanese
import slip labels. Levels: one 1cm and two 1.5cms
5358 3 bottles per lot HK\$60,000-90,000

Domaine Leroy, Latricières-Chambertin 2000
Grand Cru, Côte de Nuits
Signs of old seepage. Very slightly stained labels. Integrated US
import back labels. Levels: one 2cms and one 2.4cms
5359 2 bottles per lot HK\$35,000-50,000

Domaine Leroy, Latricières-Chambertin 2003
Grand Cru, Côte de Nuits
Sign of old seepage. Integrated US import back label. Level: 1.2cms
5360 1 bottle per lot HK\$18,000-22,000

Domaine Leroy, Latricières-Chambertin 2005
Grand Cru, Côte de Nuits
Sign of old seepage. Integrated US import back label. Level: 2cms
5361 1 bottle per lot HK\$20,000-28,000

Domaine Leroy, Latricières-Chambertin 2011
Grand Cru, Côte de Nuits
Taiwanese import slip label
5362 1 bottle per lot HK\$16,000-24,000

Domaine Leroy, Musigny 2011
Grand Cru, Côte de Nuits
Very slightly creased label. Taiwanese import slip label
5363 1 bottle per lot HK\$75,000-110,000

Domaine Leroy, Richebourg 1992
Grand Cru, Côte de Nuits
Worn capsules. One sign of seepage. One slightly stained label. One
stained vintage neck label. Taiwanese import slip labels, one badly
wine stained. Levels: one 1cm and one 1.5cms
5364 2 bottles per lot HK\$50,000-80,000

Domaine Leroy, Richebourg 2000
Grand Cru, Côte de Nuits
One slightly damaged wax capsule. One slightly damaged and
slightly stained label. One slightly damaged back label. Levels: one
1.3cms and one 1.8cms
5365 2 bottles per lot HK\$38,000-55,000

Richebourg

Grand Cru

Appellation Contrôlée

Mis en bouteille au Domaine

LEROY

Propriétaire à Vosne-Romanée, Côte-d'Or, France

PRODUCT OF FRANCE

750

Domaine Leroy, Richebourg 2011*Grand Cru, Côte de Nuits
Taiwanese import slip labels*5366 3 bottles *per lot* HK\$100,000-150,000
5367 3 "**Domaine Leroy, Romanée-Saint-Vivant 1990***Grand Cru, Côte de Nuits
Damaged wax capsules. One sign of old seepage. Slightly stained
labels. Stained vintage neck labels. Slightly damaged integrated US
import back labels. Levels: 0.5cm or better*5368 2 bottles *per lot* HK\$45,000-65,000**Domaine Leroy, Romanée-Saint-Vivant 1992***Grand Cru, Côte de Nuits
One slightly stained label otherwise excellent appearance. Slightly
stained integrated US import back labels. Taiwanese import slip
labels. Levels: two 2cms, one 2.7cms*5369 3 bottles *per lot* HK\$60,000-90,000**Domaine Leroy, Romanée-Saint-Vivant 1993***Grand Cru, Côte de Nuits
Slightly worn capsule. Very slightly damaged label. Slightly
damaged integrated US import back label. Taiwanese import slip
label. Level: 0.5cm*5370 1 bottle *per lot* HK\$26,000-35,000**Domaine Leroy, Romanée-Saint-Vivant 2011***Grand Cru, Côte de Nuits
Taiwanese import slip labels*5371 3 bottles *per lot* HK\$65,000-100,000**Domaine Leroy, Romanée-Saint-Vivant 2011***Grand Cru, Côte de Nuits
One very slightly damaged label. Taiwanese import slip labels*5372 4 bottles *per lot* HK\$90,000-130,000**Domaine Leroy, Vosne-Romanée Les Brûlées 1990***1er Cru, Côte de Nuits
Very slightly damaged wax capsule. Slightly stained label and
vintage neck label. US slip label. Level: 1.5cms*5373 1 bottle *per lot* HK\$11,000-16,000**Domaine Leroy, Vosne-Romanée Les Brûlées 2007***1er Cru, Côte de Nuits
Very slightly damaged wax capsule. Signs of seepage. One very
slightly damaged label. One wine stained vintage neck label and
back label. Taiwanese import slip labels. Levels: 2cms*5374 2 bottles *per lot* HK\$15,000-20,000**Domaine Leroy, Vosne-Romanée Les Beaux Monts 1996***1er Cru, Côte de Nuits
Slightly depressed corks. Three slightly stained labels. Three stained
vintage neck labels. US and Taiwanese import slip labels. Levels: five
1.5cms or better, one 2cms*5375 6 bottles *per lot* HK\$70,000-100,000**Domaine Leroy, Vosne-Romanée Les Beaux Monts 2002***1er Cru, Côte de Nuits
Sign of old seepage. Slightly stained label. Japanese import slip
label. Level: 2cms*5376 1 bottle *per lot* HK\$10,000-15,000**Domaine Leroy, Vosne-Romanée Les Beaux Monts 2009***1er Cru, Côte de Nuits
One sign of old seepage. Taiwanese import slip labels. Levels: one
1.8cms, one 2.5cms, one 3.2cms*5377 3 bottles *per lot* HK\$32,000-50,000**Domaine Leroy, Vosne-Romanée Les Beaux Monts 2011***1er Cru, Côte de Nuits
In twelve-bottle Leroy original wooden case. Taiwanese import slip
labels*5378 6 bottles *per lot* HK\$55,000-85,000

Romanée-Saint-Vivant

Grand Cru

Appellation Contrôlée



Mis en bouteille au Domaine

ERROY

Propriétaire à Vosne-Romanée, Côte-d'Or, France

PRODUCT OF FRANCE

Domaine Leroy, Chambolle-Musigny Les Charmes 1999
1er Cru, Côte de Nuits
Slightly depressed corks. Very slightly stained labels. Integrated US
import back labels. Levels: 0.5cm
5379 2 bottles *per lot* HK\$20,000-28,000

Domaine Leroy, Chambolle-Musigny Les Charmes 2011
1er Cru, Côte de Nuits
Taiwanese import slip label
5380 1 bottle *per lot* HK\$14,000-20,000

Domaine Leroy, Gevrey-Chambertin Les Combottes 2007
1er Cru, Côte de Nuits
Two signs of old seepage. One slightly stained label. One slightly
damaged vintage neck label. Taiwanese import slip labels
5381 4 bottles *per lot* HK\$35,000-55,000

Domaine Leroy, Vosne-Romanée Les Genaivrières 2011
Côte de Nuits
Taiwanese import slip labels
5382 3 bottles *per lot* HK\$18,000-26,000

Domaine Leroy, Chambolle-Musigny Les Fremières 1995
Côte de Nuits
Very slightly stained label. US slip label. Level: 1cm
5383 1 bottle *per lot* HK\$6,000-8,500

Domaine Leroy, Chambolle-Musigny Les Fremières 1996
Côte de Nuits
One very slightly stained label. Taiwanese import slip labels. Levels:
one 1.7cms and one 2.8cms
5384 2 bottles *per lot* HK\$13,000-17,000

Domaine Leroy, Chambolle-Musigny Les Fremières 2007
Côte de Nuits
Signs of old seepage. Taiwanese import slip labels
5385 2 bottles *per lot* HK\$10,000-15,000

Domaine Leroy, Chambolle-Musigny Les Fremières 2011
Côte de Nuits
Taiwanese import slip labels
5386 2 bottles *per lot* HK\$10,000-15,000

Domaine Leroy, Nuits-Saint-Georges Aux Allots 2007
Côte de Nuits
Sign of old seepage. Slightly stained label. Taiwanese import slip
label
5387 1 bottle *per lot* HK\$5,000-7,500

Domaine Leroy, Nuits-Saint-Georges Aux Allots 2011
Côte de Nuits
Taiwanese import slip labels
5388 3 bottles *per lot* HK\$15,000-22,000

Domaine Leroy, Nuits-Saint-Georges Aux Boudots 2007
1er Cru, Côte de Nuits
Taiwanese import slip label
5389 1 bottle *per lot* HK\$6,000-8,500

Domaine Leroy, Nuits-Saint-Georges Aux Boudots 2011
1er Cru, Côte de Nuits
Very slightly damaged labels. Taiwanese import slip labels
5390 2 bottles *per lot* HK\$12,000-18,000

Domaine Leroy, Nuits-Saint-Georges Aux Lavières 2011
Côte de Nuits
Taiwanese import slip labels
5391 2 bottles *per lot* HK\$10,000-15,000

The Glenlivet Winchester Collection Vintage 1967

Only 150 bottles of the Glenlivet Winchester Collection Vintage 1967 were produced and Christie's are delighted to be offering the first and last bottles in our autumn 2019 sales. Bottle number 1 is offered in the Hong Kong auction on 23 November and bottle number 150 is offered in the London sale on 28/29 November.

The Glenlivet Winchester Collection 1967 brings together malts from a number of rare oak casks, the youngest of which was filled in December 1967. When whisky is slowly maturing in its cask, a small amount of whisky evaporates through the wood and into the atmosphere, known as the Angel's Share. Each year, roughly 2% of the liquid leaves the cask this way, which means that 50 Year Old whisky casks will generally have lost 60-80% of their liquid. As a result, only a very small amount of precious whisky was left for bottling in June 2018.

The whisky is non-chill filtered at cask strength, and boasts a rich and fruity nose, notes of apricot jam and sweet ripe peaches, and a hint of toasted almonds. It has an incredibly smooth taste with fondant orange and milk chocolate flavours, an amazing velvety texture and a long, and luxuriously sweet finish.

The launch is the third in The Glenlivet Winchester Collection, which celebrates over 40 years of dedication to Scotch from Master Distiller Alan Winchester – and follows the release of Vintage 1966 in 2016 and Vintage 1964 in 2014, two of the most sought-after whiskies in the world.

Taking inspiration from the land that surrounds The Glenlivet distillery, former British Designer of the Year, Bethan Gray, has handcrafted the exquisite bottle and case that hold the 50 year old Scotch, to reflect the craftsmanship and exceptional quality of their contents.

The Glenlivet Master Distiller, Alan Winchester, and Bethan Gray spent many months working closely together sharing their craft and walking the Cairngorms where The Glenlivet distillery sits to produce this newest release.

"The launch of Vintage 1967 is a momentous occasion for The Glenlivet, and a particularly proud one for me personally," says The Glenlivet Master Distiller Alan Winchester. "To have my name associated with one of the finest single malts that money can buy is an honour – what a fantastic way to celebrate more than 40 years in the Scotch whisky industry. By collaborating with the talented Bethan Gray, we have been able to epitomise not only Vintage 1967's luxurious quality but also the craftsmanship that led to its creation. The result is a beautiful and captivating bottle that ensures Vintage 1967 is a feast for the eyes as well the palate."

Bethan Gray's inspiration comes from the land around The Glenlivet distillery, her family history in the area and the complex whisky itself. Bethan's grandfather lived and worked as a forester in the Cairngorms, home of The Glenlivet, and she was inspired by the landscape while exploring the area with Master Distiller Alan Winchester. The layers of mist that gather in the surrounding valleys became inspiration for the unique reinterpretation of her Dhow pattern that surrounds the bottle.

"Everything I do is about collaborating with people to tell stories through craft, so it was a real honour to work with Alan Winchester to create this incredibly special bottle of Scotch whisky", says Bethan Gray. "We're both inspired by spending time in nature, so what better inspiration than the Cairngorms, where The Glenlivet distillery is based?"

The Scotch whisky making process itself was further inspiration for Bethan. The bottle is blown by master glassblower Brodie Nairn to precisely the right size and thickness and then hand-cut, creating an ombré colour effect that mimics the ageing process of the liquid inside. It is then engraved and hand-painted, making each one unique.

The hand-stained birds-eye maple case is made using solid copper overlays that reflect The Glenlivet's charred barrels and copper stills. Created by hand by artisans, the technique used to overlay the delicate copper was invented specifically for this case in its curved form. The mother-of-pearl inlaid into the case reflects the local freshwater pearl mussel shells indigenous to the Spey River.

1967年格蘭威特溫徹斯特收藏50年蘇格蘭單一麥芽威士忌

The Glenlivet Winchester Collection Vintage 1967的產量只有150瓶，珍罕非常，而佳士得有幸於2019年秋季拍賣呈獻當中的第一瓶和最後一瓶。編號為1的威士忌將於11月23日在香港推出，而編號為150的威士忌則會於11月28至29日在倫敦拍賣。

The Glenlivet Winchester Collection Vintage 1967混合數桶以橡木桶盛載的稀有麥芽威士忌，而年份最淺的一桶於1967年12月入桶。當威士忌在木桶中慢慢成熟時，有少量威士忌會經木材揮發至空氣當中，這一部分稱為「天使的分享」。每年大概有2%的酒液會以這種方式流失，因此一桶存放50年的威士忌一般已流失六至八成酒液，所以能夠在2018年7月裝瓶的威士忌極少。

威士忌經過非冷凝過濾，展現原桶濃度，帶有濃郁的果香，並有杏脯醬和熟桃的甜味，以及一抹烤杏仁香氣。威士忌展現美妙柔順的味道，散發香橙軟糖和牛奶朱古力的風味，口感極致柔滑，餘韻甘甜悠長。

這批珍釀是The Glenlivet Winchester Collection推出的第三批美酒，領場釀酒大師艾倫溫徹斯特(Alan Winchester)在過去40多年來對蘇格蘭威士忌的熱誠。過去兩批推出市場的威士忌為1966和1964年的出品，分別於2016及2014年推出，成為全球最受藏家渴求的威士忌。

曾榮膺年度英國最佳設計師殊榮的貝唐·格雷(Bethan Gray)從環繞格蘭利威酒廠的高地汲取靈感，親自設計精緻的酒瓶和酒盒，用以盛載陳釀50年的蘇格蘭威士忌，完美體現箇中的工藝及卓越品質。

酒廠的釀酒大師溫徹斯特與格雷合作多月，各自發揮所長，並探索酒廠所在的凱恩戈姆山脈，務求為最新推出的威士忌作好準備。

釀酒大師溫徹斯特表示：「推出1967年份威士忌對格蘭利威酒廠而言是一個重大日子，也是令我深感自豪的時刻。能夠用自己的名字為世上其中一款頂級單一麥芽威士忌命名，絕對是一份榮耀，也是慶祝我40多年來精心鑽研蘇格蘭威士忌的最佳方式。我透過與才華洋溢的格雷合作，不但反映這款威士忌的超凡品質，亦體現釀造過程的精湛技藝。我們創作的酒瓶精美迷人，使The Glenlivet Winchester Collection Vintage 1967成為視覺與味覺的饗宴。」

格雷的靈感源自酒廠附近的自然風景、她的家族在區內的歷史，以及複雜細緻的威士忌。她的祖父在格蘭利威酒廠所在的凱恩戈姆山脈居住和任職林務員，她深受當地的風景啟發，並與溫徹斯特深入探索該區。於山谷縈繞不散的霧氣啟發她重新演繹瓶身的Dhow圖案。

格雷表示：「我所做的一切也著眼於人與人之間的合作，透過工藝分享故事，因此我非常榮幸能與溫徹斯特合作設計這款蘇格蘭威士忌的酒瓶。我們很享受親近大自然，因此格蘭利威酒廠所在的凱恩戈姆山脈就是最好的靈感來源。」

釀造蘇格蘭威士忌的過程亦為格雷帶來更多靈感。酒瓶由玻璃工藝大師Brodie Nairn製造，他吹製出精準的大小和厚度後，便會進行人手切割，打造漸變效果，模仿瓶內酒液的陳化過程，然後再以人手雕刻和上色，使每一個酒瓶也獨一無二。

人手染色的鳥眼楓木酒盒表面飾以紅銅細節，呼應酒廠內經過燒炙的酒桶和銅製蒸餾儀。為配合弧形木箱，工匠特別研發精細的手工技巧，仔細加上銅製裝飾，而盒面的貝母鑲嵌則反映斯佩河本地原生淡水珠貝的光澤。

The Glenlivet 50 Year-Old Winchester Collection 1967

Speyside

This 50 Year Old single malt is offered in a handcrafted bottle and case by Bethan Gray

Tasting note: rich and fruity aromas with notes of apricot jam and sweet ripe peaches and a hint of toasted almonds. On the palate, incredibly smooth and sweet with fondant orange and milk chocolate flavours in abundance all with an amazing velvety texture; with a long and luxuriously sweet finish.

5392 1 bottle per lot HK\$150,000-200,000



ESTD 1824

THE
GLENLIVET

SINGLE MALT SCOTCH WHISKY

The WINCHESTER
COLLECTION

50

YEARS of AGE

Bottled on 6th June 2018
40% ALC/VOL (80 PROOF)

THE
GLENLIVET

The WINCHESTER
COLLECTION

50

YEARS of AGE

Lot 5392

A MAGNIFICENT PRIVATE WHISKY COLLECTION

We are exceptionally proud to bring this extremely rare collection of whisky (lots 5393 to 5408) to our Hong Kong saleroom. The collection features highly-sought after and rare single-malt whisky from The Macallan and Japanese Karuizawa, Yamazaki and Ichiro. Highlights including the limited release Karuizawa "Aqua of Life" 50 Year Old and Karuizawa 36 Views Of Mount Fuji (Batch 1-28).

The Macallan 25 Years

Speyside

In original wooden case. Level: into neck. Single malt. 43% volume

5393 1 bottle per lot HK\$26,000-40,000

The Macallan 25 Years Decanter

Speyside

In original carton. Level: 2cms. Single malt. 43% volume

5394 1 bottle per lot HK\$45,000-70,000

Ichiro's Malt Hanyu Card Joker

羽生 撲克牌-小丑 (彩色)

Japan

Distilled between 1985 and 2000. Bottled in 2014. Bottle no. 2154.

Single Malt. 700ml. 57.7% volume

5395 1 bottle per lot HK\$20,000-32,000

Hakushu 25 Year Limited Edition

白州25年限定版

Japan

In banded original wooden case. Single Malt. 700ml. 43% volume

5396 1 bottle per lot HK\$20,000-32,000

Yamazaki Vintage Malt 1991

山崎蒸溜所 1991

Japan

In original carton. Bottled in 2004. Single Malt. 700ml. 56% volume

5397 1 bottle per lot HK\$24,000-38,000

The Cask of Yamazaki 1990

山崎 1990

Japan

In original carton. Bottled in 2007. One of 438 bottles. Cask no.

OM707172. Sherry butt. 700ml. 59% volume

5398 1 bottle per lot HK\$55,000-80,000



Lots 5393 & 5394



Lot 5395

Nikka Whisky 35 Year
竹鶴 35年

Japan

In original wooden case. Bottle no. 0400. 700ml. 43% volume

5399 1 bottle per lot HK\$40,000-60,000

Nikka Whisky 35 Year
竹鶴 35年

Japan

In original wooden case. Bottle no. 0422. 700ml. 43% volume

5400 1 bottle per lot HK\$40,000-60,000



Lots 5397 & 5398



Lot 5396



Lots 5399 & 5400

Suntory Yamazaki 1991

山崎1991

Japan

In original carton. Bottled in 2005. Cask no. TV70374. 700ml. 56% volume

5401 1 bottle per lot HK\$13,000-20,000

Suntory Yamazaki 1999

山崎1999

Japan

In original carton. Bottled in 2014. Cask no. DE00157. 700ml. 54% volume

5402 1 bottle per lot HK\$13,000-20,000

Karuizawa "Aqua of Life" 50 Year Old

輕井澤黑命之水50年

Japan

In original presentation wooden case. Distilled in 1968. Bottled in 2018. One of 248 bottles. Cask no. 6223. Sherry butt. Single malt. 700ml. 57.9% volume

5403 1 bottle per lot HK\$300,000-450,000

Karuizawa 1969

輕井澤1969年

Japan

In original carton. Bottled in 2012. Cask No. 8183. Ex-bourbon cask. Single Malt. 700ml. 61.3% volume

5404 1 bottle per lot HK\$60,000-90,000

Karuizawa 1981 Miyajima

輕井澤宮島辯才天

Japan

In original presentation case. Bottled in 2016. Cask No. 6809. Sherry cask. Single Malt. 700ml. 58.5% volume

5405 1 bottle per lot HK\$55,000-80,000



Lot 5404



Lots 5401 & 5402



Lot 5405



昭和四十三年

AGED
50
YEARS

命
水

KARUIZAWA VINTAGE
TRUFI CASK MALT WHISKY

Cask No. 6223
Year 2018
Cask Type Sherry Malt
Alcohol 57.9%
輕井沢蒸留所謹製
A TRULY HAND CRAFTED MALT

ONE OF THE ONLY 248 BOTTLES 700ml

命の水
KARUIZAWA DISTILLERY

輕井沢蒸留所謹製

Karuzawa Cask Strength 1st, 2nd, 3rd and 4th Release
輕井澤原酒1-4版

1st Release

In original carton. Sherry oak. Single malt. 700ml. 61.7% volume (1)

2nd Release

In original carton. Sherry oak. Single malt. 700ml. 61.7% volume (1)

3rd Release

In original carton. Sherry oak. Single malt. 700ml. 61.7% volume (1)

4th Release

In original carton. Sherry oak. Single malt. 700ml. 61.7% volume (1)

5406 4 bottles per lot HK\$35,000-55,000



Lot 5406

Karuzawa - Golden House with 5 Mistresses

輕井澤金屋藏嬌

Bottled in 2017. 1999-2000 vintages. One of 500 bottles. Sherry cask. Single malt. 180ml. 60.5% volume (1)
Bottled in 2017. 1999-2000 vintages. One of 500 bottles. Sherry cask. Single malt. 180ml. 60.6% volume (1)
Bottled in 2017. 1999-2000 vintages. One of 500 bottles. Sherry cask. Single malt. 180ml. 60.7% volume (1)
Bottled in 2017. 1999-2000 vintages. One of 500 bottles. Sherry cask. Single malt. 180ml. 60.8% volume (1)
Bottled in 2017. 1999-2000 vintages. One of 500 bottles. Sherry cask. Single malt. 180ml. 61% volume (1)

5407 5 bottles per lot HK\$28,000-42,000



Lot 5407



Lot 5408

Karuizawa 36 Views Of Mount Fuji Batch 1-28**輕井澤富嶽三十六景 (1-28景)****36 Views Of Mount Fuji #1***Distilled 1999-2000. 700ml. 61% volume***36 Views Of Mount Fuji #2***Distilled 1999-2000. 700ml. 59.5% volume***36 Views Of Mount Fuji #3***Distilled 1999-2000. 700ml. 60.5% volume***36 Views Of Mount Fuji #4***Distilled 1999-2000. 700ml. 60.1% volume***36 Views Of Mount Fuji #5***Distilled 1999-2000. 700ml. 59.6% volume***36 Views Of Mount Fuji #6***Distilled 1999-2000. 700ml. 59.7% volume***36 Views Of Mount Fuji #7***Distilled 1999-2000. 700ml. 59.2% volume***36 Views Of Mount Fuji #8***Distilled 1999-2000. 700ml. 59.2% volume***36 Views Of Mount Fuji #9***Distilled 1999-2000. 700ml. 60.8% volume***36 Views Of Mount Fuji #10***Distilled 1999-2000. 700ml. 60.9% volume***36 Views Of Mount Fuji #11***Distilled 1999-2000. 700ml. 60.5% volume***36 Views Of Mount Fuji #12***Distilled 1999-2000. 700ml. 60.7% volume***36 Views Of Mount Fuji #13***Distilled 1999-2000. 700ml. 60.8% volume***36 Views Of Mount Fuji #14***Distilled 1999-2000. 700ml. 60.5% volume***36 Views Of Mount Fuji #15***Distilled 1999-2000. 700ml. 60.6% volume***36 Views Of Mount Fuji #16***Distilled 1999-2000. 700ml. 61% volume***36 Views Of Mount Fuji #17***Distilled 1999-2000. 700ml. 60.8% volume***36 Views Of Mount Fuji #18***Distilled 1999-2000. 700ml. 60.5% volume***36 Views Of Mount Fuji #19***Distilled 1999-2000. 700ml. 60.2% volume***36 Views Of Mount Fuji #20***Distilled 1999-2000. 700ml. 60.1% volume***36 Views Of Mount Fuji #21***Distilled 1999-2000. 700ml. 61% volume***36 Views Of Mount Fuji #22***Distilled 1999-2000. 700ml. 60.8% volume***36 Views Of Mount Fuji #23***Distilled 1999-2000. 700ml. 60.9% volume***36 Views Of Mount Fuji #24***Distilled 1999-2000. 700ml. 60.7% volume***36 Views Of Mount Fuji #25***Distilled 1999-2000. 700ml. 60.8% volume***36 Views Of Mount Fuji #26***Distilled 1999-2000. 700ml. 60.7% volume***36 Views Of Mount Fuji #27***Distilled 1999-2000. 700ml. 60.4% volume***36 Views Of Mount Fuji #28***Distilled 1999-2000. 700ml. 61.1% volume*

5408 28 bottles per lot HK\$300,000-450,000

A PRIVATE COLLECTION OF CHÂTEAU CHEVAL BLANC AND PETRUS FROM THE LEGANDARY 1947 VINTAGE**Château Cheval-Blanc 1947***Saint-Émilion, 1er grand cru classé (A)**No capsule. Stained, creased and slightly damaged label with Nicolas stamp. US slip label. Level: upper shoulder*

5409 1 magnum per lot HK\$130,000-180,000

Château Cheval-Blanc 1947*Saint-Émilion, 1er grand cru classé (A)**Damaged capsule, bottom part missing. Cruse & Fils slip label. Badly stained label. Level: very top shoulder*

5410 1 magnum per lot HK\$130,000-180,000

Petrus 1947*Pomerol, cru exceptionnel**Bin-soiled and damaged label with Nicolas stamp. US slip label. Level: top shoulder*

5411 1 magnum per lot HK\$110,000-170,000

Petrus 1947*Pomerol, cru exceptionnel**Bin-soiled and slightly damaged label with Nicolas stamp. US slip label. Level: mid-shoulder*

5412 1 magnum per lot HK\$110,000-170,000

Petrus 1947*Pomerol, cru exceptionnel**Damaged and cut capsule. Damaged and badly stained label with Nicolas stamp. US slip label. Level: mid-upper shoulder*

5413 1 magnum per lot HK\$110,000-170,000

Petrus 1947*Pomerol, cru exceptionnel**Sign of seepage. Bin-soiled and slightly damaged label with Nicolas stamp. US slip label. Level: upper shoulder*

5414 1 magnum per lot HK\$110,000-170,000

Petrus 1947*Pomerol, cru exceptionnel**Bin-soiled and slightly damaged label with Nicolas stamp. US slip label. Level: mid-upper shoulder*

5415 1 magnum per lot HK\$110,000-170,000

Château Lafite-Rothschild 1999*Pauillac, 1er cru classé**Three bottles with metal security strips attached on labels. Levels: base of neck or better*

▲5416 4 bottles per lot HK\$18,000-26,000

AN EXCEPTIONAL BANDED CASE OF CHÂTEAU LAFITE-ROTHSCHILD 2003

Château Lafite-Rothschild 2003

*Pauillac, 1er cru classé
In banded original wooden case*

5417 6 magnums *per lot HK\$90,000-130,000*

Château Haut-Brion Blanc 2005

*Pessac (Graves), cru classé
In original wooden cases*

△ 5418 6 bottles *per lot HK\$28,000-42,000*

△ 5419 6 "

5420 No lot

A WONDERFUL BANDED CASE OF LE PIN 2016

Le Pin 2016

*Pomerol
In banded original wooden case*

5421 6 bottles *per lot HK\$120,000-180,000*

RARE MAISON LEROY MUSIGNY FROM A PRIVATE COLLECTOR

Maison Leroy, Musigny 1990

*Grand Cru, Côte de Nuits
One damaged and three slightly damaged capsules, one cut to reveal branded cork. One stained and one ballpen marked labels. One stained vintage neck label. Levels: five 2.5cms, three 2.7cms, one 3cms*

5422 9 bottles *per lot HK\$280,000-350,000*



Lot 5422

ROYAL HOUSEHOLD WHISKY FROM A PRIVATE COLLECTION

Royal Household Scotch Whisky

*Whisky
In original cartons. Japanese import back labels. Levels: into neck.
750ml. 43% volume*

5423 6 bottles *per lot HK\$9,000-14,000*

5424 6 "

5425 6 "

5426 6 "

5427 6 "

5428 6 "

5429 6 "

Clarendon Hills, Astralis 2000

McLaren Vale

△ 5430 12 bottles *per lot HK\$11,000-19,000*

AN IMMACULATE BORDEAUX COLLECTION

The following lots 5431 to 5440 feature an impressive selection of finest & rarest wines. Highlights include lovely vintages of Cru Classé Bordeaux from the 1996 and Armand Rousseau from the 2004, which we are sure will be a delight to taste, explore and enjoy.

Château Latour 1996

*Pauillac, 1er cru classé
In damaged tissues. Levels: into neck*

5431 4 bottles *per lot HK\$18,000-26,000*

Château Lafite-Rothschild 2008

*Pauillac, 1er cru classé
In twelve-bottle original wooden case with damaged lid. In slightly damaged tissues. Levels: into neck*

5432 4 bottles *per lot HK\$18,000-26,000*

Domaine Armand Rousseau, Chambertin 2004

Grand Cru, Côte de Nuits

5433 1 bottle *per lot HK\$9,500-14,000*

Domaine Armand Rousseau, Ruchottes-Chambertin Clos des Ruchottes 2004

Grand Cru, Côte de Nuits

5434 3 bottles *per lot HK\$7,000-11,000*

Domaine Perrot-Minot, Nuits-Saint-Georges Les Cras Vieilles Vignes 2009

*1er Cru, Côte de Nuits
In original carton*

5435 12 bottles *per lot HK\$7,500-11,000*

Domaine Perrot-Minot, Nuits-Saint-Georges Les Murgers Vieilles Vignes 2009

*Côte de Nuits
In original carton*

5436 12 bottles *per lot HK\$7,500-11,000*

M. Chapoutier, Châteauneuf-du-Pape Barbe Rac 1998*Rhône**In individual original wooden cases*5437 5 magnums *per lot* HK\$6,500-9,500**M. Chapoutier, Châteauneuf-du-Pape Barbe Rac 2000***Rhône**In individual original wooden cases*5438 10 magnums *per lot* HK\$9,500-14,000**Clos des Papes, Châteauneuf-du-Pape 2007***Rhône**In original wooden case*5439 12 bottles *per lot* HK\$9,000-14,000**Vega Sicilia, Alion 2004***Ribera del Duero**In original wooden case*5440 12 bottles *per lot* HK\$5,500-8,500**A PRESTIGIOUS COLLECTION OF FINEST WINES**

The following lots 5441 to 5449 feature an impressive selection of finest & rarest wines from Burgundy, Rhône and Spain. Highlights include 1978 DRC Montrachet and Jaboulet Hermitage La Chapelle 1969. All the wines were bought from reputable sources and recently removed from custom-built private cellars stored in impeccable conditions.

Domaine de la Romanée-Conti, Montrachet 1978*Grand Cru, Côte de Beaune**Slightly corroded capsule. Mature colour. Leroy slip label. Level: 4cms*5441 1 bottle *per lot* HK\$50,000-75,000**Domaine de la Romanée-Conti, Montrachet 2000***Grand Cru, Côte de Beaune**Slightly damaged HK import back label. Level: 3cms*5442 1 bottle *per lot* HK\$40,000-60,000**Mixed 1999 & 2003 Emmanuel Rouget, Vosne-Romanée Cros Parantoux****1999**

(1)

2003

(1)

5443 2 bottles *per lot* HK\$22,000-32,000**Mixed 1997 & 1999 Emmanuel Rouget, Echézeaux****1997**

(2)

1999

(2)

5444 4 bottles *per lot* HK\$22,000-32,000**Mixed 2000 & 2002 Emmanuel Rouget, Echézeaux****2000**

(2)

2002

(2)

5445 4 bottles *per lot* HK\$22,000-32,000**Dugat-Py, Chambertin 1999***Grand Cru, Côte de Nuits**Slightly bin-soiled label. Level: 1cm*5446 1 bottle *per lot* HK\$13,000-19,000**Mixed 1990s Dugat-Py, Charmes-Chambertin****1993***Slightly stained labels. Levels: 1cm*

(2)

1994*Slightly stained labels. Levels: 1cm*

(2)

1995*Slightly stained labels. Levels: 1cm*

(2)

1996*Slightly faded capsules. Slightly stained labels. Levels: 1cm*

(2)

1998*Slightly faded capsules. Slightly stained labels. Levels: one 1cm, one 2cms*

(2)

5447 10 bottles *per lot* HK\$24,000-38,000

Lots 5423-5429

Paul Jaboulet Aîné, Hermitage La Chapelle 1969

Rhône, Paul Jaboulet Aîné

One sign of seepage. One stained vintage neck label. Five slightly stained and one stained labels. Levels: five 3cms, one 3.5cms, one 4.3cms

5448 7 bottles *per lot* HK\$28,000-50,000

Vega Sicilia Unico, Reserva Especial

Ribera del Duero

Released in 2004. A blend of 1985, 1990 and 1991

5449 12 bottles *per lot* HK\$24,000-38,000

AN OUTSTANDING PRIVATE COLLECTION

The following lots 5450 to 5459 are from an European private collection featuring the rarest Burgundy wines from Georges Roumier and Henri Mayer. The 1992 Screaming Eagle completes the collection.

Mixed Château Margaux and Armand Rousseau

1994 Château Margaux

Loose capsule. Bin-soiled label. Italian import slip label. Level: into neck (1)

2000 A. Rousseau, Chambertin

Stained and very slightly damaged capsule. Damaged neck label (1)

2002 A. Rousseau, Gevrey-Chambertin Clos Saint-Jacques

Slightly worn capsule. Very slightly damaged label (1)

5450 3 bottles *per lot* HK\$17,000-26,000

Domaine de la Romanée-Conti, Romanée-Saint-Vivant 2014

Grand Cru, Côte de Nuits

Italian import back label

5451 1 bottle *per lot* HK\$11,000-18,000

Georges Roumier, Musigny 1995

Grand Cru, Côte de Nuits

Loose capsule. Heavily bin-soiled label. Level: 1cm

5452 1 bottle *per lot* HK\$70,000-95,000

Georges Roumier, Musigny 1998

Grand Cru, Côte de Nuits

Loose capsules, one cut to reveal branded cork. Heavily bin-soiled labels. Levels: 0.8cm

5453 2 bottles *per lot* HK\$80,000-110,000

Georges Roumier, Musigny 1999

Grand Cru, Côte de Nuits

Cut capsule to reveal branded cork. Heavily bin-soiled label. Level: 0.5cm

5454 1 bottle *per lot* HK\$70,000-95,000

Henri Mayer, Richebourg 1985

Grand Cru, Côte de Nuits

Loose capsule. Depressed cork. Bin-soiled label. Level: 2.3cms

5455 1 bottle *per lot* HK\$120,000-180,000

Henri Mayer, Echézeaux 1985

Grand Cru, Côte de Nuits

Depressed cork. Cut capsule to reveal branded cork. Slightly damaged and heavily bin-soiled label. Stained vintage neck label. Level: 2.6cms

5456 1 bottle *per lot* HK\$48,000-70,000

Henri Mayer, Vosne-Romanée Cros Parantoux 1999

1er Cru, Côte de Nuits

Depressed cork. Bin-soiled label. Level: 1.7cms

5457 1 bottle *per lot* HK\$70,000-95,000

Mixed G. Conterno and Masseto

1982 G. Conterno Barolo Riserva Monfortino

Very slightly damaged label. Level: base of neck (1)

2010 Masseto

Very slightly stained label (1)

5458 2 bottles *per lot* HK\$13,000-19,000

Screaming Eagle 1992

Napa Valley

Loose and slightly damaged capsule. Very slightly damaged label. Level: into neck

5459 1 bottle *per lot* HK\$48,000-70,000



Lot 5455

FINE CALIFORNIAN WINES DIRECT FROM KISTLER VINEYARDS

The following lots from 5460 to 5463 are the fine Californian wines direct from Kistler Vineyards. Kistler Vineyards is a privately owned and operated winery dedicated to the vinification of world class site specific Chardonnay and Pinot Noir. Kistler produce single vineyard Chardonnay and Pinot Noirs that are available exclusively to their mailing list members and Christie's is delighted to be offering their superb wines for the first time at auction direct from the winery. The wines were delivered to Hong Kong from Kistler specifically for this auction.

Kistler Vineyards was founded in 1978 by Steve Kistler and Mark Bixler. The first vintage in 1979 produced 3,500 cases of wine and since then the winery has slowly grown to the planned production level of about 35,000 cases per year. Jason Kesner oversees all winemaking and vineyard operations. Jason became connected to Kistler in the summer of 2000 when he joined Hudson Vineyards and began growing the fruit for our Hudson bottling. Jason then joined Steve Kistler in the cellar in 2008 as Assistant Winemaker for Kistler Vineyards and became Winemaker in 2014. Steve retired from Kistler Vineyards at the end of 2017.

Kistler, Hyde Vineyard Chardonnay Vertical

2013	(3)	
2014	(3)	
2015	(3)	
2016	(3)	
5460	12 bottles	per lot HK\$6,000-9,000

Kistler, Kistler Vineyard Chardonnay Vertical

2011	(3)	
2012	(3)	
2013	(3)	
2014	(3)	
5461	12 bottles	per lot HK\$7,000-10,000

Kistler, Laguna Ridge Vineyard Pinot Noir 2016

<i>Russian River Valley, USA</i>	
5462	6 magnums per lot HK\$8,000-11,000

Kistler, Cuvée Natalie Pinot Noir Vertical

2011	(2)	
2012	(2)	
2013	(2)	
2014	(2)	
2015	(2)	
2016	(2)	
<i>Slight signs of old seepage</i>		
5463	12 bottles per lot HK\$8,000-11,000	



A GREAT SOUTH AFRICAN PRIVATE COLLECTION**Mixed Château Palmer and Alter Ego de Palmer****1979 Château Palmer***Released from Mähler-Besse in 2008. Slightly damaged capsule.**Level: upper shoulder*

(1)

1989 Château Palmer*Damaged label. Level: base of neck*

(1)

2005 Château Palmer

(1)

2006 Château Palmer

(1)

2008 Château Palmer

(1)

2009 Château Palmer

(1)

2010 Château Palmer

(1)

2011 Château Palmer

(1)

*Above 6 bottles in original wooden case***2010 Alter Ego de Palmer***One very slightly damaged label*

(2)

•5464 10 bottles

*per lot HK\$9,500-12,000***François Raveneau, Chablis Grand Cru Blanchot 2014***Grand Cru**South African import back labels*

•5465 4 bottles

*per lot HK\$10,000-14,000***Mixed Pierre-Yves Colin-Morey, Saint-Aubin****2011 Saint-Aubin Les Banc***Two slightly damaged labels*

(3)

2012 Saint-Aubin Les Banc*Slightly stained label*

(1)

2015 Saint-Aubin Les Banc*Slightly damaged label*

(1)

2011 Saint-Aubin Les Meurgers des Dents de Chien*Two damaged and one slightly damaged labels*

(3)

2012 Saint-Aubin Les Champlots*Very slightly stained labels, one damaged*

(2)

2015 Saint-Aubin Les Champlots*Very slightly damaged labels*

(4)

2011 Saint-Aubin La Chatenièrre*Damaged labels*

(2)

All slightly damaged South African import labels

•5466 16 bottles

*per lot HK\$5,000-6,500***Mixed Soldera, Brunello di Montalcino****2006 Brunello di Montalcino Riserva***Two slightly damaged labels. Slightly damaged South African**import back labels*

(4)

2009 Brunello di Montalcino*South African import back label*

(1)

•5467 5 bottles

*per lot HK\$12,000-14,000***Vega Sicilia Unico, Reserva Especial NV***Ribera del Duero**2017 release. A blend of 2003, 2004 and 2006. In original wooden case. South African import back labels*

•5468 3 bottles

*per lot HK\$4,800-7,000***A PRESTIGIOUS COLLECTION OF FINEST & RAREST WINES
FEATURING A STUNNING COLLECTION OF BURGUNDY**

The following lots 5469 to 5623 are the prestigious collection features an incredible collection of finest & rarest wines from classic regions. Of note is the impressive array of Burgundy, particularly from Romanée-Conti, Dugat-Py and Domaine Ponsot. All the top Burgundy Domaines are represented offering buyers the opportunity to purchase wines that are produced in extremely limited quantities and are very hard to find. Also included are multiple ex-Chateau cases from Bordeaux; carefully selected offering from Italy and rare Screaming Eagle Sauvignon Blanc from California. The provenance of this collection is unparalleled and the conditions are generally excellent.

Krug 2002*Reims**In six-bottle original cartons*

5469 12 bottles

*per lot HK\$22,000-32,000***Pol Roger, Winston Churchill 2002***Epernay**In original carton with gift boxes*

5470 6 bottles

*per lot HK\$6,000-9,000***Pol Roger, Winston Churchill 2004***Epernay**In original carton*

5471 3 magnums

*per lot HK\$5,500-8,500***Agrapart & Fils, Avizoise 2011***Champagne**In original carton*

5472 6 bottles

*per lot HK\$3,200-4,800***Château Léoville-Barton 2016***Saint-Julien, 2ème cru classé**In original wooden case*

5473 12 bottles

per lot HK\$6,000-9,000

Château Lascombes 2010
Margaux, 2ème cru classé
In original wooden cases
 5474 24 bottles *per lot* HK\$14,000-20,000

Château Ausone 2013
Saint-Emilion, 1er grand cru classé (A)
In banded six-bottle original wooden cases
 5475 12 bottles *per lot* HK\$30,000-45,000

Château Le Tertre-Roteboeuf 2011
Saint-Emilion, grand cru classé
In original wooden case
 5476 12 bottles *per lot* HK\$10,000-15,000

Le Pin 2016
Pomerol
In banded individual original wooden cases
 5477 2 bottles *per lot* HK\$40,000-60,000

Château La Violette 2007
Pomerol
In original wooden case
 5478 1 double-magnum *per lot* HK\$4,500-7,000

Château Saint Pierre 2015
Pomerol
In original wooden cases
 5479 24 bottles *per lot* HK\$7,000-10,000

Château Roc de Cambes 2013
Côtes de Bourg
In original wooden cases
 5480 24 bottles *per lot* HK\$6,000-9,000

Marquis d'Angerville, Volnay Champans 2014
1er Cru, Côte de Beaune
In six-bottle original cartons
 5481 12 bottles *per lot* HK\$6,000-9,000

Marquis d'Angerville, Volnay Caillerets 2014
1er Cru, Côte de Beaune
In six-bottle original cartons
 5482 12 bottles *per lot* HK\$6,000-9,000

Domaine de L'Arlot, Nuits St. Georges Clos des Forets St. Georges 2015
1er Cru, Côte de Nuits
In original cartons
 5483 24 bottles *per lot* HK\$13,000-19,000

Mixed Domaine de L'Arlot
2015 Vosne-Romanée Les Suchots (3)
2015 Nuits St. Georges Mont des Oiseaux (12)
In original carton
2016 Nuits St. Georges Clos des Forets St. Georges (12)
In original carton
 5484 27 bottles *per lot* HK\$11,000-16,000

Arnoux Lachaux, Clos Vougeot 2015
Grand Cru, Côte de Nuits
In twelve-bottle original carton
 5485 6 bottles *per lot* HK\$8,500-13,000

Arnoux Lachaux, Nuits St. Georges Clos des Corvées Pagets 2011
1er Cru, Côte de Nuits
In original carton
 5486 12 bottles *per lot* HK\$6,000-9,000

Arnoux Lachaux, Vosne-Romanée Les Chaumes 2016
1er Cru, Côte de Nuits
In original carton
5487 12 bottles *per lot* HK\$9,000-14,000

Arnoux Lachaux, Chambolle-Musigny 2014
Côte de Nuits
In original cartons
5488 24 bottles *per lot* HK\$7,000-10,000

Henri Boillot, Pommard Les Rugiens 2013
1er Cru, Côte de Beaune
In original cartons
5489 24 bottles *per lot* HK\$11,000-16,000

Henri Boillot, Pommard Les Rugiens 2014
1er Cru, Côte de Beaune
In original cartons
5490 24 bottles *per lot* HK\$10,000-15,000

Henri Boillot, Volnay Les Chevrets 2015
1er Cru, Côte de Beaune
In six-bottle original cartons
5491 24 bottles *per lot* HK\$12,000-18,000

Henri Boillot, Clos de Vougeot 2013
Grand Cru, Côte de Nuits
In original carton
5492 12 bottles *per lot* HK\$9,000-14,000



Lot 5487

Bruno Clair, Savigny-lès-Beaune La Dominode 2012

1er Cru, Côte de Beaune

In original cartons

5493 24 bottles *per lot* HK\$9,500-14,000

Bruno Clair, Gevrey-Chambertin 2014

Côte de Nuits

In original cartons

5494 24 bottles *per lot* HK\$8,500-13,000

Christian Confuron & Fils, Musigny 2009

Grand Cru, Côte de Nuits

In original wooden case. Slightly stained vintage neck label

5495 1 jeroboam *per lot* HK\$14,000-20,000

Christian Confuron & Fils, Musigny 2010

Grand Cru, Côte de Nuits

In individual original wooden cases

5496 2 magnums *per lot* HK\$12,000-18,000

Mommessin, Clos de Tart 2011

Grand Cru, Côte de Nuits

In six-bottle original wooden cases

5497 12 bottles *per lot* HK\$26,000-35,000

5498 12 "

Mommessin, Clos de Tart 2014

Grand Cru, Côte de Nuits

In six-bottle original wooden cases

5499 12 bottles *per lot* HK\$28,000-38,000

5500 12 "

Coche Dury, Meursault 2013

Côte de Beaune

5501 12 bottles *per lot* HK\$45,000-60,000

Domaine des Comtes Lafon, Volnay Santenots-du-Milieu 2015

1er Cru, Côte de Beaune

In original cartons

5502 24 bottles *per lot* HK\$15,000-22,000

Jean-Jacques Confuron, Clos de Vougeot 2013

Grand Cru, Côte de Nuits

In original cartons

5503 12 bottles *per lot* HK\$9,000-14,000

5504 12 "

Jean-Jacques Confuron, Chambolle-Musigny 2014

Côte de Nuits

In original cartons

5505 24 bottles *per lot* HK\$7,500-11,000

Domaine de la Romanée-Conti, Richebourg 1961

Grand Cru, Côte de Nuits

Ex-Christie's NY Zaffaroni auction in June 2015. Frederick Wildman & Sons front slip label & Sherry Wine & Spirits back slip label.

Oxidized, corroded and slightly damaged capsule. Slightly bin-soiled label. Level: 6cms

5506 1 bottle *per lot* HK\$13,000-19,000

Domaine de la Romanée-Conti, Richebourg 1966

Grand Cru, Côte de Nuits

Ex-Christie's NY Zaffaroni auction in June 2015. Frederick Wildman slip labels. Oxidized capsules. Bin-soiled labels. Levels: one 5.5cms,

one 7.2cms

5507 2 bottles *per lot* HK\$28,000-42,000



Lot 5501

Domaine de la Romanée-Conti, Grands-Echézeaux 1962
Grand Cru, Côte de Nuits
Ex-Christie's NY Zaffaroni auction in June 2015. Frederick Wildman
slip label. Oxidized capsule. Bin-soiled label. Level: 4.5cms
5508 1 bottle *per lot* HK\$28,000-42,000

Dugat-Py, Gevrey-Chambertin Champeaux 2011
1er Cru, Côte de Nuits
5509 6 bottles *per lot* HK\$7,500-11,000

Dugat-Py, Gevrey-Chambertin Cœur de Roy 2014
Côte de Nuits
In original cartons
5510 12 bottles *per lot* HK\$8,500-12,000
5511 12 "

Dugat-Py, Gevrey-Chambertin Vieilles Vignes 2011
Côte de Nuits
In original cartons
5512 12 bottles *per lot* HK\$6,500-9,500

Dugat-Py, Gevrey-Chambertin Vieilles Vignes 2014
Côte de Nuits
In original cartons
5513 24 bottles *per lot* HK\$12,000-18,000

Domaine Dujac, Morey-Saint-Denis 1er Cru 2016
1er Cru, Côte de Nuits
In original carton
5514 6 bottles *per lot* HK\$5,500-8,500

Dujac Fils & Père, Clos de la Roche 2013
Grand Cru, Côte de Nuits
5515 6 bottles *per lot* HK\$11,000-17,000

Dujac Fils & Père, Clos de la Roche 2016
Grand Cru, Côte de Nuits
In six-bottle original cartons
5516 12 bottles *per lot* HK\$38,000-55,000

Dujac Fils & Père, Nuits-Saint-Georges Les Damodes 2013
1er Cru, Côte de Nuits
In original carton
5517 12 bottles *per lot* HK\$4,500-7,000

Mixed Arnaud Ente, Meursault Clos des Ambres
2009 (2)
2010
One sign of old seepage (2)
5518 4 bottles *per lot* HK\$13,000-19,000

Domaine Faiveley, Corton-Charlemagne 2015
Grand Cru, Côte de Beaune
In six-bottle original wooden cases
5519 12 bottles *per lot* HK\$12,000-18,000

Domaine Faiveley, Meursault-Charmes 2016
1er Cru, Côte de Beaune
In six-bottle original cartons
5520 24 bottles *per lot* HK\$12,000-18,000

Domaine Faiveley, Volnay Santenots 2016
1er Cru, Côte de Beaune
In six-bottle original cartons
5521 24 bottles *per lot* HK\$9,000-14,000

Domaine Faiveley, Charmes-Chambertin 2016
Grand Cru, Côte de Nuits
In six-bottle original wooden cases
5522 12 bottles *per lot* HK\$13,000-19,000

Domaine Faiveley, Clos de Vougeot 2016
Grand Cru, Côte de Nuits
In banded six-bottle original wooden cases
5523 12 bottles *per lot* HK\$11,000-16,000
5524 12 "



LA ROCHE
 ND CRU
 VE LA ROCHE CONTRÔLÉE
 016
 s en bouteille par Dujac
 ILS & PÈRE
 ST-DENIS-FRANCE



CLOS DE LA ROCHE
 GRAND CRU

APPELLATION CLOS DE LA ROCHE CONTRÔLÉE

2016

Vinifié, élevé et mis en bouteille par Dujac

DUJAC FILS & PÈRE

21220 MOREY-ST-DENIS-FRANCE

13.5% alc / vol (27.5°) - PRODUCED IN FRANCE

Domaine Faiveley, Corton Clos de Cortons 2006
Grand Cru, Côte de Beaune
In six-bottle original wooden cases
5525 24 bottles *per lot* HK\$12,000-18,000

Domaine Faiveley, Corton Clos de Cortons 2016
Grand Cru, Côte de Beaune
In banded six-bottle original wooden cases
5526 12 bottles *per lot* HK\$12,000-18,000
5527 12 "

Domaine Faiveley, Latricières-Chambertin 2014
Grand Cru, Côte de Nuits
In six-bottle original wooden cases
5528 12 bottles *per lot* HK\$9,000-13,000
5529 12 "

Domaine Faiveley, Gevrey-Chambertin Clos des Issarts 2016
1er Cru, Côte de Nuits
In six-bottle original cartons
5530 24 bottles *per lot* HK\$10,000-15,000

Domaine Faiveley, Gevrey-Chambertin La Combe aux Moines 2016
1er Cru, Côte de Nuits
In six-bottle original cartons
5531 24 bottles *per lot* HK\$8,500-13,000

Domaine Faiveley, Nuits St. Georges Aux Chaignots 2004
1er Cru, Côte de Nuits
In six-bottle original cartons
5532 24 bottles *per lot* HK\$7,000-11,000

Domaine Faiveley, Nuits St. Georges Les Damodes 2007
1er Cru, Côte de Nuits
In six-bottle original cartons
5533 24 bottles *per lot* HK\$7,000-10,000

Domaine Faiveley, Nuits St. Georges Les Porêts Saint-Georges 2010
1er Cru, Côte de Nuits
In six-bottle original cartons
5534 24 bottles *per lot* HK\$8,500-13,000

Domaine Faiveley, Nuits St. Georges Les Porêts Saint-Georges 2016
1er Cru, Côte de Nuits
In six-bottle original cartons
5535 24 bottles *per lot* HK\$7,500-11,000

Domaine Faiveley, Chambolle-Musigny Aux Beaux Bruns 2015
1er Cru, Côte de Nuits
In six-bottle original cartons
5536 12 bottles *per lot* HK\$4,800-7,500

Domaine Faiveley, Chambolle-Musigny Les Charmes 2015
1er Cru, Côte de Nuits
In six-bottle original cartons
5537 24 bottles *per lot* HK\$13,000-20,000

J.F. Mugnier, Nuits St. Georges Clos de la Maréchale Rouge 2016
1er Cru, Côte de Nuits
In six-bottle original wooden cases
5538 24 bottles *per lot* HK\$13,000-19,000

J.F. Mugnier, Chambolle-Musigny Les Fuées 2013
1er Cru, Côte de Nuits
From two sources
5539 3 bottles *per lot* HK\$4,500-7,000

Lucien Le Moine, Pommard Les Epenots 2011
1er Cru, Côte de Beaune
In six-bottle original cartons
5540 12 bottles *per lot* HK\$5,500-8,000

Lucien Le Moine, Charmes-Chambertin 2012
Grand Cru, Côte de Nuits
In original carton
5541 6 bottles *per lot* HK\$6,500-9,500

Lucien Le Moine, Chambertin-Clos de Bèze 2013
Grand Cru, Côte de Nuits
In six-bottle original cartons
5542 12 bottles *per lot* HK\$19,000-28,000

Lucien Le Moine, Clos Saint-Denis 2014

*Grand Cru, Côte de Nuits
In six-bottle original cartons*

5543 12 bottles *per lot* HK\$11,000-17,000

Lucien Le Moine, Chambolle-Musigny Les Groseilles 2012

*1er Cru, Côte de Nuits
In six-bottle original cartons*

5544 12 bottles *per lot* HK\$6,000-9,000

Lucien Le Moine, Nuits St. Georges Les Vaucraains 2014

*1er Cru, Côte de Nuits
In six-bottle original cartons*

5545 24 bottles *per lot* HK\$14,000-20,000

Lucien Le Moine, Morey-Saint-Denis Les Genavrières 2015

*1er Cru, Côte de Nuits
In six-bottle original cartons*

5546 24 bottles *per lot* HK\$11,000-16,000

Lucien Le Moine, Gevrey-Chambertin Les Champeaux 2016

*1er Cru, Côte de Nuits
In six-bottle original cartons*

5547 12 bottles *per lot* HK\$5,500-8,000

Michel Magnien, Charmes-Chambertin 2016

*Grand Cru, Côte de Nuits
In original cartons*

5548 12 bottles *per lot* HK\$12,000-19,000

5549 12 "



Lot 5542

Michel Magnien, Clos de la Roche 2015

Grand Cru, Côte de Nuits

In original carton

5550 12 bottles *per lot* HK\$11,000-17,000

Michel Magnien, Clos de la Roche 2016

Grand Cru, Côte de Nuits

In original cartons

5551 12 bottles *per lot* HK\$11,000-17,000

5552 12 "

Michel Magnien, Clos Saint-Denis 2014

Grand Cru, Côte de Nuits

In original carton

5553 12 bottles *per lot* HK\$10,000-15,000

Michel Magnien, Clos Saint-Denis 2016

Grand Cru, Côte de Nuits

In original carton

5554 12 bottles *per lot* HK\$13,000-19,000

Michel Magnien, Gevrey-Chambertin Les Cazetiers 2014

1er Cru, Côte de Nuits

In original cartons

5555 24 bottles *per lot* HK\$7,500-11,000

Michel Magnien, Morey-Saint-Denis Les Chaffots 2015

1er Cru, Côte de Nuits

In original cartons

5556 24 bottles *per lot* HK\$7,000-10,000



Lots 5562 & 5563

Michel Magnien, Morey-Saint-Denis Les Millandes 2014*1er Cru, Côte de Nuits**In original cartons*5557 24 bottles *per lot* HK\$7,500-11,000**Domaine de Montille, Corton-Charlemagne 2016***Grand Cru, Côte de Beaune**In original cartons*5558 12 bottles *per lot* HK\$8,500-12,000

5559 12 "

Maison de Montille, Meursault Les Porusots 2015*1er Cru, Côte de Beaune**In original cartons*5560 24 bottles *per lot* HK\$11,000-16,000**Domaine de Montille, Puligny-Montrachet Le Cailleret 2015***1er Cru, Côte de Beaune**In original cartons*5561 24 bottles *per lot* HK\$15,000-22,000**Domaine de Montille, Corton Clos du Roi 2016***Grand Cru, Côte de Beaune**In original cartons*5562 12 bottles *per lot* HK\$8,500-12,000

5563 12 "

Domaine de Montille, Volnay Les Mitans 2014*1er Cru, Côte de Beaune**In original cartons*5564 24 bottles *per lot* HK\$11,000-16,000**Domaine de Montille, Volnay Les Taillepieds 2016***1er Cru, Côte de Beaune**In original cartons*5565 24 bottles *per lot* HK\$14,000-20,000**Domaine de Montille, Pommard Les Rugiens-Bas 2016***1er Cru, Côte de Beaune**In original carton*5566 6 bottles *per lot* HK\$4,200-6,500**Domaine de Montille, Beaune Les Sizies 2015***1er Cru, Côte de Beaune**In original cartons*5567 24 bottles *per lot* HK\$6,000-9,000**Domaine de Montille, Clos Vougeot 2016***Grand Cru, Côte de Nuits**In original carton*5568 12 bottles *per lot* HK\$13,000-19,000**Domaine de Montille, Nuits St. Georges Aux Thorey 2016***1er Cru, Côte de Nuits**In original cartons*5569 24 bottles *per lot* HK\$9,000-14,000**Domaine de Montille, Vosne-Romanée Les Malconsorts 2014***1er Cru, Côte de Nuits**In original carton*5570 12 bottles *per lot* HK\$20,000-32,000**Michel Niellon, Chassagne-Montrachet Clos Saint-Jean Rouge 2016***1er Cru, Côte de Beaune**In original cartons*5571 24 bottles *per lot* HK\$6,000-9,000**Olivier Bernstein, Charmes-Chambertin 2014***Grand Cru, Côte de Nuits**In six-bottle original wooden cases*5572 12 bottles *per lot* HK\$17,000-26,000

5573 12 "



Lots 5572 & 5573

Olivier Bernstein, Clos de la Roche 2014
Grand Cru, Côte de Nuits
In six-bottle original wooden cases
 5574 12 bottles *per lot* HK\$18,000-26,000

Olivier Bernstein, Clos de Vougeot 2013
Grand Cru, Côte de Nuits
In six-bottle original wooden cases
 5575 12 bottles *per lot* HK\$14,000-22,000
 5576 12 "

Olivier Bernstein, Chambolle-Musigny Les Lavrottes 2016
1er Cru, Côte de Nuits
In six-bottle original wooden cases
 5577 12 bottles *per lot* HK\$13,000-19,000

Olivier Bernstein, Gevrey-Chambertin Les Champeaux 2013
1er Cru, Côte de Nuits
Lot 5578: In six-bottle original wooden cases
Lot 5579: In six-bottle original wooden cases. Two slightly stained labels
 5578 12 bottles *per lot* HK\$8,000-12,000
 5579 12 "

Domaine Ponsot, Corton-Charlemagne 2016
Grand Cru, Côte de Beaune
In six-bottle original wooden cases
 5580 12 bottles *per lot* HK\$18,000-26,000

Domaine Ponsot, Clos de la Roche Vieilles Vignes 2012
Grand Cru, Côte de Nuits
In six-bottle original wooden cases
 5581 12 bottles *per lot* HK\$30,000-45,000

Domaine Ponsot, Charmes-Chambertin Cuvée des Merles 2014
Grand Cru, Côte de Nuits
In six-bottle original wooden cases
 5582 12 bottles *per lot* HK\$18,000-24,000

Château Grillet 2015
Rhône
In original wooden case
 5583 6 bottles *per lot* HK\$9,500-14,000

Cerbaiona, Brunello di Montalcino 2012
Tuscany
In six-bottle original wooden cases
 5584 24 bottles *per lot* HK\$15,000-22,000

Gaja, Barolo Dagromis 2015
Piedmont
In six-bottle original cartons
 5585 24 bottles *per lot* HK\$9,000-14,000

Gaja, Costa Russi 2014
Piedmont
In six-bottle original wooden cases
 5586 12 bottles *per lot* HK\$22,000-30,000

Gaja, Sori San Lorenzo 2014
Piedmont
In six-bottle original wooden cases
 5587 12 bottles *per lot* HK\$22,000-30,000
 5588 12 "

Gaja, Sori Tildin 2014
Piedmont
In six-bottle original wooden cases
 5589 12 bottles *per lot* HK\$22,000-30,000
 5590 12 "

Gaja, Darmagi 2013
Piedmont
In six-bottle original wooden cases
 5591 12 bottles *per lot* HK\$11,000-17,000
 5592 12 "

Gaja, Pieve di Santa Restituta Brunello di Montalcino Rennina 2013
Tuscany
In six-bottle original wooden cases
 5593 12 bottles *per lot* HK\$8,000-12,000
 5594 12 "

Gaja, Pieve di Santa Restituta Brunello di Montalcino Sugaril 2013
Tuscany
In six-bottle original wooden cases
 5595 12 bottles *per lot* HK\$9,000-14,000

Gaja, Ca' Marcanda Camarcanda 2015
Tuscany
In six-bottle original wooden cases
 5596 24 bottles *per lot* HK\$14,000-22,000

Tenuta dell'Ornellaia, Ornellaia 2015
Tuscany
In six-bottle original wooden cases
 5597 24 bottles *per lot* HK\$22,000-35,000

Tenuta dell'Ornellaia, Le Serre Nuove 2015
Tuscany
In six-bottle original cartons
 5598 24 bottles *per lot* HK\$5,000-7,500

Tenuta dell'Ornellaia, Le Serre Nuove 2016
Tuscany
In six-bottle original cartons
 5599 24 bottles *per lot* HK\$4,800-7,500

Oremus, Tokaji Eszencia 2006
Hungary
In three half-bottle original wooden cases
 5600 12 half-bottles *per lot* HK\$16,000-24,000

Mixed Quinta do Noval
2004 Nacional
In individual original wooden cases (2)
2015 Vintage Port
In six-bottle original wooden cases (12)
 5601 14 bottles *per lot* HK\$9,000-15,000

Vega Sicilia Unico 2006
Ribera del Duero
In three-bottle original wooden cases
 5602 12 bottles *per lot* HK\$19,000-28,000
 5603 12 "

Vega Sicilia Unico, Reserva Especial NV
Ribera del Duero
2018 release. A blend of 2005, 2006 and 2007. In three-bottle original wooden cases
 5604 12 bottles *per lot* HK\$22,000-32,000
 5605 12 "

Vega Sicilia, Valbuena 5° 2013
Ribera del Duero
In three-bottle original wooden cases
 5606 24 bottles *per lot* HK\$12,000-18,000

Vega Sicilia, Alion 2014
Ribera del Duero
In six-bottle original wooden cases
 5607 24 bottles *per lot* HK\$7,000-10,000

Eisele Vineyard, Cabernet Sauvignon 2014
Napa Valley
In three-bottle original wooden cases
 5608 12 bottles *per lot* HK\$28,000-40,000
 5609 12 "

Araujo, Altavracia Cabernet Sauvignon 2012
Napa Valley
In six-bottle original cartons
 5610 24 bottles *per lot* HK\$14,000-20,000

Eisele Vineyard, Altavracia Cabernet Sauvignon 2014
Napa Valley
In six-bottle original cartons
 5611 24 bottles *per lot* HK\$14,000-20,000

Bond, Melbury 2014
Napa Valley
In six-bottle original wooden cases
 5612 12 bottles *per lot* HK\$28,000-38,000

Bond, Quella 2014
Napa Valley
In six-bottle original wooden cases
 5613 12 bottles *per lot* HK\$30,000-45,000

Bond, St. Eden 2015
Napa Valley
In six-bottle original wooden cases
 5614 12 bottles *per lot* HK\$42,000-65,000

Bond, Vecina 2015

Napa Valley

In six-bottle original wooden cases

5615 12 bottles per lot HK\$38,000-55,000

Colgin, IX Estate 2013

Napa Valley

In three-bottle original wooden cases

5616 12 bottles per lot HK\$35,000-50,000

Dana Estate, Helms Vineyard Cabernet Sauvignon 2014

Rutherford

In three-bottle original wooden cases. Some original tissues missing

5617 12 bottles per lot HK\$32,000-48,000

Dana Estate, Hershey Vineyard Cabernet Sauvignon 2015

Howell Mountain

In three-bottle original wooden cases

5618 12 bottles per lot HK\$32,000-48,000

Dana Estate, Onda Cabernet Sauvignon 2014

Napa Valley

In six-bottle original wooden cases

5619 12 bottles per lot HK\$11,000-16,000

5620 12 "

Screaming Eagle, Sauvignon Blanc 2016

Napa Valley

Slightly damaged original tissue

5621 1 bottle per lot HK\$30,000-45,000

Screaming Eagle 2012

Napa Valley

In three-bottle original wooden case

5622 1 bottle per lot HK\$17,000-26,000

Screaming Eagle 2014

Napa Valley

In three-bottle original wooden case without wooden tracks

5623 2 bottles per lot HK\$28,000-45,000



Lot 5614

A PRESTIGIOUS EUROPEAN COLLECTION

We are very proud to be able to offer you this selection of wines from one of the finest collections in Europe (lots 5624-5781). A breathtaking collection of finest Bordeaux back to 1961. This collection features beautiful full dozens of Lafite and Latour 1989, Mouton 1961 and a range of Hermitage La Chapelle 1983.

Pommery, Cuvée Spéciale 1961

Reims

Damaged foiled capsules. Bin-soiled labels. Levels: four good levels, one 1cm and one 2cms below foil

5624 6 bottles per lot HK\$14,000-22,000

Gosset, Grande Réserve Brut NV

Champagne

Irish import slip labels

5625 36 bottles per lot HK\$5,500-7,500

Château Cos d'Estournel 1989

Saint-Estéphe, 2ème cru classé

In original wooden cases. US slip labels. Levels: into neck

5626 12 bottles per lot HK\$11,000-18,000

5627 12 "

Château Calon-Ségur 1966

Saint-Estéphe, 3ème cru classé

One damaged capsule. Bin-soiled, stained and slightly damaged labels. Levels: seven top shoulder, five upper shoulder

5628 12 bottles per lot HK\$4,500-7,000

Château Calon-Ségur 1989

Saint-Estéphe, 3ème cru classé

Some slightly damaged capsules. Some damaged and slightly bin-soiled labels. Levels: base of neck or better

5629 12 bottles per lot HK\$6,500-10,000

5630 12 "

5631 12 "

Château Calon-Ségur 1989

Saint-Estéphe, 3ème cru classé

Lots 5632-5636: Some slightly damaged capsules. Some damaged and slightly bin-soiled labels. Levels: base of neck or better

Lot 5637: Some slightly damaged capsules. Damaged and slightly bin-soiled labels. Levels: top shoulder or better

5632 24 bottles per lot HK\$13,000-20,000

5633 24 "

5634 24 "

5635 24 "

5636 24 "

5637 24 "

Château de Pez 1975

Saint-Estéphe, cru bourgeois supérieur

Stained and damaged labels, some detached. Two bottles without the label, believed vintage 1975. Levels: base of neck or better

5638 24 bottles per lot HK\$7,000-10,000

Château Lafite-Rothschild 1989

Pauillac, 1er cru classé

In original wooden case. Excellent appearance with original tissues. Levels: base of neck or better

5639 12 bottles per lot HK\$60,000-85,000

Château Lafite-Rothschild 1989

Pauillac, 1er cru classé

Lots 5640-5643: Excellent appearance. Levels: into neck

Lot 5644: Two slightly damaged labels otherwise excellent appearance. Levels: into neck

5640 12 bottles per lot HK\$60,000-85,000

5641 12 "

5642 12 "

5643 12 "

5644 12 "

Château Latour 1961

Pauillac, 1er cru classé

One sign of old seepage. Bin-soiled and damaged labels. Excellent colour. Levels: two top shoulder, one upper shoulder

5645 3 bottles per lot HK\$70,000-110,000



Lots 5629 - 5631



MIS EN BOUTEILLE AU CHATEAU

GRAND VIN
DE
CHATEAU LATOUR

PREMIER GRAND CRU CLASSE

PAUILLAC

1976

PRODUCE OF FRANCE

APPELLATION PAUILLAC CONTROLEE

MAISON FONDÉE EN 1765

MAISON CIVILE DU VIGNOBLE DE CHATEAU LATOUR, PROPRIETAIRE A PAUILLAC

Château Latour 1962*Pauillac, 1er cru classé**Bin-soiled and slightly damaged labels. Remains of tissues stained on bottle. Levels: top shoulder or better*5646 6 bottles *per lot* HK\$28,000-42,000**Château Latour 1964***Pauillac, 1er cru classé**Slightly corroded capsule. Slightly depressed cork. Slightly bin-soiled label. Level: top shoulder*5647 1 magnum *per lot* HK\$6,500-10,000**Château Latour 1976***Pauillac, 1er cru classé**Some slightly damaged labels. Levels: base of neck or better*5648 12 bottles *per lot* HK\$26,000-40,000

5649 12 "

5650 12 "

Château Latour 1979*Pauillac, 1er cru classé**Two slightly damaged capsules. Bin-soiled labels. Levels: base of neck or better*5651 6 bottles *per lot* HK\$13,000-20,000**Château Latour 1989***Pauillac, 1er cru classé**In original wooden cases with original tissues. Levels: base of neck or better*5652 12 bottles *per lot* HK\$35,000-50,000

5653 12 "

5654 12 "

Château Latour 1990*Pauillac, 1er cru classé**Slightly bin-soiled labels. Levels: base of neck or better*5655 6 bottles *per lot* HK\$28,000-40,000**Château Latour 1999***Pauillac, 1er cru classé**In original wooden case*5656 12 bottles *per lot* HK\$35,000-50,000**Château Mouton-Rothschild 1961***Pauillac, 1er cru classé**Mähler-Besse slip labels. Bin-soiled and slightly damaged labels.**One damaged label. One missing label, believe vintage 1961. Levels: five top shoulder, three mid-upper shoulder, four mid-shoulder*5657 12 bottles *per lot* HK\$170,000-240,000

Lot 5657

Château Mouton-Rothschild 1967*Pauillac, 1er cru classé**Slightly corroded capsules. Bin-soiled and slightly damaged labels.**Levels: top shoulder or better*5658 6 magnums *per lot* HK\$20,000-30,000**Château Mouton-Rothschild 1967***Pauillac, 1er cru classé**Corroded capsules, one slightly damaged. Bin-soiled and slightly**damaged labels. Levels: upper shoulder or better*5659 6 magnums *per lot* HK\$20,000-30,000**Château Mouton-Rothschild 1967***Pauillac, 1er cru classé**Corroded capsules. Two signs of old seepage. Bin-soiled and slightly damaged labels. Levels: one top shoulder, two upper shoulder, one mid-upper shoulder, two mid shoulder*5660 6 magnums *per lot* HK\$20,000-30,000**Château Mouton-Rothschild 1989***Pauillac, 1er cru classé**Badly damaged and damp stained front and back labels. Remains of original tissues stained on labels, some detached. Levels: base of neck or better*5661 12 bottles *per lot* HK\$35,000-50,000**Château Mouton-Rothschild 1989***Pauillac, 1er cru classé**Very badly damaged and badly damp stained front and back labels.**Remains of original tissues stained on labels, some vintage illegible.**Levels: base of neck or better*5662 12 bottles *per lot* HK\$35,000-50,000

5663 12 "

Château Duhart-Milon 1989*Pauillac, 4ème cru classé**Lots 5664-5669: In original wooden cases. Levels: base of neck or better**Lot 5670: Not in original wooden case. Slightly bin-soiled labels.**Levels: base of neck or better*5664 24 bottles *per lot* HK\$9,500-14,000

5665 24 "

5666 24 "

5667 24 "

5668 24 "

5669 24 "

5670 24 "

Château Duhart-Milon 1989*Pauillac, 4ème cru classé**Lot 5671: In original wooden cases. Levels: base of neck or better**Lot 5672: Not in original wooden case. Slightly bin-soiled labels.**Levels: base of neck or better*5671 36 bottles *per lot* HK\$14,000-22,000

5672 36 "

Château Grand-Puy-Lacoste 1989*Pauillac, 5ème cru classé**Slightly bin-soiled and slightly damaged labels. Levels: base of neck or better*5673 24 bottles *per lot* HK\$15,000-24,000

5674 24 "

5675 24 "

Château Lynch-Bages 1989*Pauillac, 5ème cru classé**Slightly stained and slightly damaged labels. Levels: base of neck or better*5676 12 bottles *per lot* HK\$24,000-35,000

5677 12 "

5678 12 "

5679 12 "

5680 12 "

5681 12 "

Château Lynch-Bages 1997*Pauillac, 5ème cru classé**Levels: into neck*5682 24 bottles *per lot* HK\$15,000-22,000**Château Talbot Caillou Blanc 1990***Bordeaux**Slightly damaged capsules. Bin-soiled and damaged labels. Levels: base of neck or better*5683 24 bottles *per lot* HK\$7,500-11,000**Château Talbot 2001***Saint-Julien, 4ème cru classé**In original wooden cases*5684 24 bottles *per lot* HK\$9,500-14,000

5685 24 "

Château Branaire-Ducru 1961*Saint-Julien, 4ème cru classé**Bin-soiled and slightly damaged labels. Levels: nine top shoulder, three mid-upper shoulder*5686 12 bottles *per lot* HK\$24,000-38,000

Mixed 1970 & 1975 Château Branaire-Ducru

1970

Slightly damaged capsules. Bin-soiled and slightly damaged labels. One missing label, believed vintage 1970. Levels: nine upper shoulder, three mid-upper shoulder (12)

1975

Some very slightly damaged capsules. Bin-soiled and slightly damaged labels. Levels: top shoulder or better (24)

5687 36 bottles per lot HK\$12,000-18,000

Château Lagrange 1989

Saint-Julien, 3ème cru classé

In original wooden cases. Some very slightly stained labels. Levels: base of neck or better

5688 24 bottles per lot HK\$10,000-16,000

5689 24 "
5690 24 "
5691 24 "
5692 24 "
5693 24 "
5694 24 "
5695 24 "
5696 24 "
5697 24 "

Château Gloria 1976

Saint-Julien, cru bourgeois supérieur

Bin-soiled and slightly damaged labels. One badly damaged label. Levels: twenty one base of neck, three upper shoulder

5698 24 bottles per lot HK\$8,000-12,000

Château Gloria 1989

Saint-Julien, cru bourgeois supérieur

Slightly bin-soiled labels, some very slightly damaged. Levels: base of neck or better

5699 24 bottles per lot HK\$8,000-13,000

5700 24 "

Château Gloria 1989

Saint-Julien, cru bourgeois supérieur

Slightly bin-soiled labels, some very slightly damaged. Levels: base of neck or better

5701 36 bottles per lot HK\$12,000-19,000



Lots 5688 - 5697

Château La Lagune 1989*Ludon (Médoc), 3ème cru classé**Some slightly damaged capsules. Bin-soiled and slightly damaged labels. Levels: base of neck or better*5702 24 bottles *per lot* HK\$8,500-13,000
5703 24 "**Château La Lagune 1989***Ludon (Médoc), 3ème cru classé**Some slightly damaged capsules. Bin-soiled and slightly damaged labels. Levels: base of neck or better*5704 36 bottles *per lot* HK\$13,000-19,000**Château Margaux 1966***Margaux, 1er cru classé**Bin-soiled, stained and slightly damaged labels. Levels: one top shoulder, three upper shoulder, one mid-shoulder*5705 5 bottles *per lot* HK\$11,000-17,000**Château Margaux 1970***Margaux, 1er cru classé**Slightly corroded capsules. Bin-soiled, slightly stained and slightly damaged labels. Levels: six top shoulder, four upper shoulder*5706 10 bottles *per lot* HK\$13,000-19,000**Château Margaux 1989***Margaux, 1er cru classé**Slightly bin-soiled labels, two very slightly damaged and one slightly faded. Levels: into neck*5707 12 bottles *per lot* HK\$32,000-48,000**Château Lascombes 1995***Margaux, 2ème cru classé**In three-magnum original wooden cases*5708 12 magnums *per lot* HK\$9,000-14,000**Château Lascombes 1996***Margaux, 2ème cru classé**Some very slightly damaged labels, otherwise good appearance.**Levels: into neck*5709 12 magnums *per lot* HK\$9,000-14,000

5710 12 "

5711 12 "

5712 12 "

5713 12 "

Château Lascombes 1996*Margaux, 2ème cru classé**Lots 5714-5717: Some very slightly damaged labels, otherwise good appearance. Levels: into neck**Lot 5718: Six creased and slightly damaged, twelve very slightly**damaged labels. Levels: into neck*5714 18 magnums *per lot* HK\$13,000-20,000

5715 18 "

5716 18 "

5717 18 "

5718 18 "

Château Lascombes 2001*Margaux, 2ème cru classé**In original wooden cases*5719 24 bottles *per lot* HK\$11,000-18,000

5720 24 "

Château Lascombes 2002*Margaux, 2ème cru classé**In original wooden cases*5721 24 bottles *per lot* HK\$11,000-18,000

5722 24 "

5723 24 "

Château Lascombes 2003*Margaux, 2ème cru classé**In original wooden cases*5724 24 bottles *per lot* HK\$12,000-19,000

5725 24 "



Lots 5709 - 5713

Mixed 1997 & 2004 Château Lascombes**1997**

In original wooden case. Very slightly damaged labels. Levels: into neck magnums (6)

2004

In original wooden case (12)
5726 6 magnums and 12 bottles *per lot* HK\$9,500-15,000

Château Rauzan-Gassies 1970

Margaux, 2ème cru classé
Three damaged capsules. Bin-soiled labels. Levels: eleven base of neck or better, one top shoulder

5727 12 bottles *per lot* HK\$4,500-7,000

Château Rauzan-Gassies 1983

Margaux, 2ème cru classé
Slightly bin-soiled and slightly damaged labels. Levels: base of neck or better

5728 36 bottles *per lot* HK\$11,000-17,000
5729 36 "
5730 36 "
5731 36 "
5732 36 "

Château Rauzan-Gassies 1989

Margaux, 2ème cru classé
Slightly bin-soiled and very slightly damaged labels. Levels: base of neck or better

5733 24 bottles *per lot* HK\$9,000-14,000
5734 24 "
5735 24 "

Château Cantenac-Brown 1989

Cantenac (Margaux), 3ème cru classé
Slightly bin-soiled and slightly damaged labels. Levels: base of neck or better

5736 24 bottles *per lot* HK\$8,000-13,000
5737 24 "
5738 24 "
5739 24 "

Château d'Issan 1989

Cantenac (Margaux), 3ème cru classé
Lots 5740-5741: In original wooden cases. Slightly bin-soiled labels. Levels: base of neck or better
Lot 5742: Twelve bottles in original wooden case. Slightly bin-soiled labels. Levels: base of neck or better
Lot 5743: Slightly bin-soiled labels. Levels: base of neck or better

5740 24 bottles *per lot* HK\$8,500-14,000
5741 24 "
5742 24 "
5743 24 "

Château Giscours 1970

Labarde (Margaux), 3ème cru classé
Corroded and damaged capsules. Loose and badly stained labels. Levels: four top shoulder, four upper shoulder, two mid-upper shoulder, two mid shoulder

5744 12 bottles *per lot* HK\$8,500-13,000

Château Giscours 1975

Labarde (Margaux), 3ème cru classé
Bin-soiled and very slightly damaged labels. Levels: base of neck or better

5745 12 bottles *per lot* HK\$6,000-9,000

Château Malescot-Saint-Exupéry 1970

Margaux, 3ème cru classé
Some slightly damaged capsules. Bin-soiled labels. Levels: upper shoulder or better

5746 23 bottles *per lot* HK\$8,000-13,000



Lots 5733 - 5735

Château Palmer 1966

Cantenac (Margaux), 3ème cru classé
Slightly damaged capsules. Bin-soiled labels, some very slightly damaged. Levels: six base of neck, three upper shoulder, three mid-upper shoulder

5747 12 bottles per lot HK\$45,000-70,000

Château Prieuré-Lichine 1989

Cantenac (Margaux), 4ème cru classé
Bin-soiled and slightly damaged labels, some detached. Levels: base of neck or better

5748 36 bottles per lot HK\$12,000-18,000

5749 36 "

5750 36 "

5751 36 "

Château Prieuré-Lichine 1989

Cantenac (Margaux), 4ème cru classé
Seven bottles without labels, believed vintage 1989. Bin-soiled and slightly damaged labels, some detached. Levels: base of neck or better

5752 36 bottles per lot HK\$12,000-18,000

Château Haut-Brion 1967

Pessac (Graves), 1er cru classé
Bin-soiled and slightly stained labels. Levels: eleven 3cms or better, one 4cms

5753 12 bottles per lot HK\$19,000-28,000

Petrus 1970

Pomerol, cru exceptionnel
Slightly corroded capsules. Slightly bin-soiled and slightly damaged labels, one detached. Levels: one top shoulder, one mid-upper shoulder and one mid shoulder

5754 3 bottles per lot HK\$42,000-65,000

Petrus 1981

Pomerol, cru exceptionnel
Slightly damaged capsules. Bin-soiled and slightly damaged labels. Levels: into neck

5755 3 magnums per lot HK\$55,000-85,000

Petrus 1982

Pomerol, cru exceptionnel
Slightly bin-soiled and slightly damaged labels. Levels: into neck

5756 2 bottles per lot HK\$45,000-65,000

Petrus 1983

Pomerol, cru exceptionnel
Slightly damaged capsules. Slightly damaged and slightly bin-soiled labels, one creased. Levels: into neck

5757 3 magnums per lot HK\$60,000-90,000

Petrus 1985

Pomerol, cru exceptionnel
No label. Cut capsule to reveal vintage branded cork. Level: into neck

5758 1 magnum per lot HK\$24,000-32,000

Petrus 1985

Pomerol, cru exceptionnel
Slightly corroded and slightly damaged capsules. Five slightly bin-soiled, stained and slightly damaged labels. One badly damaged labels, vintage illegible, believed vintage 1985. Levels: base of neck or better

5759 6 magnums per lot HK\$150,000-200,000

Petrus 1988

Pomerol, cru exceptionnel
In original wooden cases. Bin-soiled and very slightly damaged labels. Levels: into neck

5760 6 magnums per lot HK\$140,000-220,000

5761 6 "

Petrus 1989

Pomerol, cru exceptionnel
In original wooden case. One damaged capsule. Two very slightly damaged labels. Levels: into neck

5762 6 magnums per lot HK\$280,000-420,000

Clos René 1962

Pomerol
Bordeaux bottling by Calvet. Bin-soiled labels, two damaged. Levels: five top shoulder, seven mid-upper shoulder or better

5763 12 bottles per lot HK\$7,000-10,000

Château Cheval-Blanc 1995*Saint-Émilion, 1er grand cru classé (A)**Levels: into neck*5764 6 bottles *per lot* HK\$16,000-24,000**Château Canon 1970***Saint-Émilion, 1er grand cru classé**Bin-soiled and slightly damaged labels. Levels: five top shoulder, seven upper shoulder*5765 12 bottles *per lot* HK\$7,500-11,000**Château Tertre Daugay 1962***Saint-Émilion, grand cru**British bottling. Five badly damaged and detached labels. Seven bin-soiled labels. Levels: six base of neck, five top shoulder, one upper shoulder*5766 12 bottles *per lot* HK\$7,000-11,000**Mixed Beaune from Bouchard & Patriarche Père & Fils****1957 Bouchard Père & Fils, Beaune***One corroded capsule. Bin-soiled, slightly damaged and slightly detached labels. One missing label, believed vintage 1957. Levels: 4cms or better* (10)**1969 Patriarche Père & Fils, Beaune***Slightly damaged capsules. Bin-soiled and slightly damaged labels, two detached. Levels: 4cms or better* (7)5767 17 bottles *per lot* HK\$14,000-22,000**Ropiteau Frères, Volnay Clos des Chênes 1966***1er Cru, Côte de Beaune**Corroded capsules. Bin-soiled and slightly damaged labels. One detached vintage neck label. Levels: seventeen 6cms or better, one 6.5cms*5768 18 bottles *per lot* HK\$7,500-10,000**Henri Darnat, Meursault Clos du Domaine 2005***Côte de Beaune**In slightly damaged original cartons. Some slightly damp stained labels*5769 36 bottles *per lot* HK\$8,500-13,000

5770 36 "

Henri Darnat, Meursault Clos du Domaine 2005*Côte de Beaune**In slightly damaged original cartons. Some slightly damp stained labels*5771 48 bottles *per lot* HK\$11,000-17,000

5772 48 "

Paul Jaboulet-Aîné, Hermitage La Chapelle 1983*Rhône**Bin-soiled and damaged integrated Irish import front labels and neck labels. Levels: 3cms or better*5773 24 bottles *per lot* HK\$22,000-32,000

5774 24 "

5775 24 "

5776 24 "

5777 24 "

5778 24 "

Paul Jaboulet-Aîné, Hermitage La Chapelle 1983*Rhône**Badly bin-soiled and badly damaged integrated Irish import front labels and neck labels. Levels: 4cms or better*5779 24 bottles *per lot* HK\$20,000-30,000

5780 24 "

5781 24 "



Lots 5760 & 5761



Decanter[®]

ASIA WINE AWARDS

2019

Mixed Lots from the 2019 Decanter Asia Wines Awards

The following lots 5782 to 5839 are offered on behalf of Decanter and are drawn from the samples submitted to their 2019 Asia Wine Awards. Funds raised from the sale will go towards The Decanter Asia Wine Scholarship Programme, which supports Asia's most promising wine palates and future wine professionals. The scholarship programme gives tomorrow's experts the opportunity to study the vineyards of the world and to become world opinion formers in the industry. This programme will help create the upcoming leaders of the Asian wine industry. Remaining funds will be distributed amongst a range of charities selected by the Decanter team.

Each case contains 12 different bottles from the region or country indicated and all are packed in Christie's cartons following selection by Christie's and Decanter team.

Lots 5782 to 5839 are offered with no reserves.

Bordeaux

Mixed cases from the most famous wine region in the world. Wines from prestigious left-bank and right-bank villages are to be found.

•5782	48 bottles	per lot	HK\$4,000-6,500
•5783	48 "		
•5784	48 "		

Tuscany

Some of Tuscany's most famous names including Chianti, Chianti Classico and Brunello di Montalcino.

•5785	48 bottles	per lot	HK\$2,800-4,000
•5786	48 "		
•5787	48 "		
•5788	60 bottles	per lot	HK\$3,500-5,000
•5789	60 "		
•5790	60 "		

Piedmont

Arguably Italy's most revered wine region, these cases of Piedmont wines offer wonderful examples of Barolo and Barbera d'Asti amongst others.

•5791	48 bottles	per lot	HK\$2,600-4,200
•5792	48 "		
•5793	48 "		
•5794	48 "		
•5795	48 "		

Veneto

The land of Valpolicella, Amarone, and Prosecco, these cases will show you the diversity and quality found in North-East Italy.

•5796	60 bottles	per lot	HK\$4,000-5,500
•5797	60 "		
•5798	60 "		
•5799	60 "		
•5800	84 bottles	per lot	HK\$5,500-7,500
•5801	84 "		

Spain

Showcasing Spain's diversity, these cases include examples that hail from the length and breadth of the country; regions that can be found include Cava, Ribera del Duero, Priorat, Toro, Rias Baixas and, of course, Rioja.

•5802	72 bottles	per lot	HK\$4,800-7,000
•5803	72 "		
•5804	72 "		
•5805	72 "		
•5806	72 "		
•5807	72 "		
•5808	84 bottles	per lot	HK\$5,500-8,000
•5809	84 "		
•5810	84 "		
•5811	84 "		
•5812	84 "		
•5813	84 "		
•5814	84 "		

Victoria, Tasmania & Western Australia

A broad mix of whites and reds selected from Australia's cooler climate regions.

- 5815 60 bottles *per lot* HK\$4,200-6,000
- 5816 60 "
- 5817 60 "
- 5818 96 bottles *per lot* HK\$6,500-9,000
- 5819 96 "
- 5820 96 "
- 5821 96 "

South & South Eastern Australia

Mainly reds from Australia's most famous wine producing regions including Barossa Valley, McLaren Vale and Coonawarra.

- 5822 96 bottles *per lot* HK\$6,500-9,000
- 5823 96 "
- 5824 96 "
- 5825 108 bottles *per lot* HK\$7,500-10,000
- 5826 108 "
- 5827 108 "
- 5828 108 "
- 5829 108 "

New Zealand

Some of the very best examples of New World Pinot Noir and Sauvignon Blanc.

- 5830 72 bottles *per lot* HK\$4,800-7,500
- 5831 72 "
- 5832 72 "
- 5833 84 bottles *per lot* HK\$5,500-8,000
- 5834 84 "
- 5835 84 "

North America

Lots of classic Californian Cabernet and Chardonnay, and also some eclectic examples from Canada.

- 5836 60 bottles *per lot* HK\$5,000-7,500
- 5837 60 "
- 5838 60 "
- 5839 60 "

End of Sale
拍賣結束

Index by Vintage

WINE	Lot No.	WINE	Lot No.
CHAMPAGNE		1979	
2002		Château Latour	5651
Krug	5469	1981	
Pol Roger, Winston Churchill	5470	Petrus	5755
Salon Le Mesnil Blanc de Blancs	5284	1982	
2004		Château Gruaud-Larose	5071
Pol Roger, Winston Churchill	5471	Château Léoville-Las-Cases	5070
2011		Château Lynch-Bages	5069
Agrapart & Fils, Avizoise	5472	Château Latour	5011
NV		Petrus	5756
Gosset, Grande Réserve Brut	5625	1983	
WHITE BOREAUX		Château Rauzan-Gassies	5728-5732
1986		Petrus	5757
Château d'Yquem	5266	1985	
1990		Château Mouton-Rothschild	5078
Château Talbot Caillou Blanc	5683	Petrus	5758-5759
2005		1986	
Château Haut-Brion Blanc	5418-5419	Château Lafite-Rothschild	5004, 5064-5065, 5211
2006		Château Léoville-Barton	5017
Château Laville Haut-Brion	5030	Château Margaux	5072-5073
2016		Château Mouton-Rothschild	5067, 5079
"Y" Château d'Yquem	5319	1988	
Pavillon Blanc du Château Margaux	5302	Château Haut-Brion	5264
MIXED		Petrus	5760-5761
Mixed Sauternes	5051	1989	
RED BORDEAUX		Château Calon Ségur	5629-5637
1945		Château Cantanec-Brown	5736-5739
Château Mouton-Rothschild	5212-5213	Château Cos d'Estournel	5285, 5626-5627
1947		Château d'Issan	5740-5743
Château Cheval Blanc	5409-5410	Château Duhart-Milon	5664-5672
Petrus	5411-5415	Château Gloria	5699-5701
1961		Château Grand-Puy-Lacoste	5673-5675
Château Branaire-Ducru	5686	Château Haut-Brion	5074
Château Latour	5645	Château La Lagune	5702-5704
Château Mouton-Rothschild	5657	Château Lafite-Rothschild	5076, 5639-5644
1962		Château Lagrange	5688-5697
Château Latour	5646	Château Latour	5086, 5652-5654
Château Tertre Daugay	5766	Château Lynch-Bages	5676-5681
Clos Rene	5763	Château Margaux	5707
1964		Château Mouton-Rothschild	5661-5663
Château Latour	5647	Château Palmer	5025
1966		Château Prieuré-Lichine	5748-5752
Château Calon Ségur	5628	Château Rauzan-Gassies	5733-5735
Château Margaux	5705	Le Pin	5223
Château Palmer	5747	Petrus	5095, 5215-5217, 5762
1967		1990	
Château Haut Brion	5753	Château Latour	5068, 5655
Château Mouton-Rothschild	5658-5660	Château Margaux	5214
1970		Château Montrose	5001
Château Canon	5765	Château Mouton-Rothschild	5080
Château Giscours	5744	Château Talbot	5020
Château Malescot-Saint-Exupéry	5746	Le Pin	5224
Château Margaux	5706	Petrus	5218-5219
Château Rauzan-Gassies	5727	1993	
Petrus	5754	Château Margaux	5088
1974		1994	
Petrus	5094	Château Mouton-Rothschild	5081
1975		1995	
Château de Pez	5638	Château Cheval Blanc	5764
Château Giscours	5745	Château Grand-Puy-Lacoste	5016
1976		Château Lascombes	5708
Château Gloria	5698	Château Pichon-Longueville, Lalande	5299
Château Latour	5648-5650	1996	
		Château Lascombes	5709-5718
		Château Latour	5012, 5431

Index by Vintage

WINE	Lot No.	WINE	Lot No.
1997		Les Forts de Latour	5298
Petrus	5096	2010	
Château Lynch-Bages	5682	Château Angelus	5316-5317
1998		Château Ausone	5318
Château Palmer	5307	Château Haut Brion	5308-5309
1999		Château Lafite-Rothschild	5007, 5290
Château Cheval Blanc	5314	Château Lascombes	5474
Château Lafite-Rothschild	5416	Château Latour	5015, 5297
Château Latour	5656	Château Margaux	5305
2000		Château Mouton-Rothschild	5084, 5293
Château Bellevue	5046	Château La Violette	5045
Château Haut-Brion	5028, 5265	Châteaux Montrose	5287
Château La Mondotte	5048	Le Pin	5039
Château Lafite-Rothschild	5066, 5077	Petrus	5036
Château Latour	5296	2011	
Château Margaux	5021	Château Lafite-Rothschild	5291
Château Trotanoy	5311	Château Margaux	5306
Petrus	5220-5222	Château Mouton-Rothschild	5294-5295
2001		Château Tertre-Roteboeuf	5476
Château Cheval Blanc	5315	2012	
Château Cos d'Estournel	5286	Château L'IF	5049
Château Lascombes	5719-5720	2013	
Château Talbot	5684-5685	Château Ausone	5475
2002		Château Roc de Cambes	5480
Château Lascombes	5721-5723	2015	
Château Latour	5087	Château Saint Pierre	5479
Château Mouton-Rothschild	5008	2016	
Petrus	5097	Château Ducru-Beaucaillou	5300
2003		Château Léoville-Barton	5473
Château Lafite-Rothschild	5005, 5417	Châteaux Montrose	5288
Château Lascombes	5724-5725	Le Pin	5421, 5477
Château Léoville-Poyferré	5301	MIXED	
Petrus	5032	Mixed Château Montrose & Château Lafite Rothschild	5003
2004		Mixed Château Margaux	5024
Petrus	5098	Mixed Château La Mission Haut Brion	5031
2005		Mixed Château Lafleur	5041
Château L'Eglise Clinet	5042	Mixed Château d'Yquem	5050
Château Margaux	5022-5023	Mixed Château Mouton-Rothschild	5085
Château Mouton-Rothschild	5009	Mixed Château Latour and Château Margaux	5090
Château Palmer	5026-5027	Mixed Château Ducru-Beaucaillou	5091
Château Pape Clément	5029	Mixed Château Haut-Brion	5092
Château Troplong Mondot	5047	Mixed Bordeaux Left Bank	5093
Château Latour	5013-5014	Mixed Bordeaux Right Bank	5099
2006		Mixed Château Margaux and Armand Rousseau	5450
Château Lafleur	5040	Mixed Château Palmer and Alter Ego de Palmer	5464
Château Margaux	5089	Mixed 1970 & 1975 Château Branaire-Ducru	5687
Château Mouton-Rothschild	5010, 5082	Mixed 1997 & 2004 Château Lascombes	5726
Petrus	5033-5034		
Vieux Château Certan	5312-5313	WHITE BURGUNDY	
2007		1978	
Château La Violette	5478	Domaine de la Romanée-Conti, Montrachet	5441
2008		1997	
Château La Mission Haut Brion	5310	Domaine de la Romanée-Conti, Montrachet	5225
Château Lafite-Rothschild	5432	1999	
Petrus	5035	Domaine de la Romanée-Conti, Montrachet	5226-5227
2009		2000	
Château Lafite-Rothschild	5006, 5289	Domaine de la Romanée-Conti, Montrachet	5228, 5442
Château Léoville-Las Cases	5018	2002	
Château Léoville-Poyferré	5019	Domaine de la Romanée-Conti, Montrachet	5229
Château L'Evangile	5043	Domaine d'Auvenay, Criots-Bâtard-Montrachet	5242
Château Margaux	5303-5304	2003	
Château Montrose	5002	Domaine d'Auvenay, Chevalier-Montrachet	5241
Château Mouton-Rothschild	5083, 5292	2004	
Château La Violette	5044	Domaine d'Auvenay, Criots-Bâtard-Montrachet	5243
Le Pin	5037-5038	Domaine de la Romanée-Conti, Montrachet	5230

Index by Vintage

WINE	Lot No.	WINE	Lot No.
2005		1995	
Henri Darnat, Meursault Clos du Domaine	5769-5772	Domaine Leroy, Chambolle-Musigny Les Fremières	5383
2009		Georges Roumier, Musigny	5452
Domaine Bouchard Père & Fils, Montrachet	5321	1996	
Joseph Drouhin, Beaune Clos des Mouches Blanc	5323	Domaine de la Romanée-Conti, Romanée-Conti	5102
2011		Domaine Leroy, Chambolle-Musigny Les Fremières	5384
Domaine de la Romanée-Conti, Bourgogne Hautes Côtes de Nuits Blanc	5320	Domaine Leroy, Clos de la Roche	5254
Domaine Leroy, Corton-Charlemagne	5332-5333	Domaine Leroy, Vosne-Romanée Les Beaux Monts	5282, 5375
Domaine Leroy, Bourgogne Aligote	5334	1997	
2013		Domaine Leroy, Clos de Vougeot	5345
Coche Dury, Meursault	5501	Domaine Leroy, Latricières-Chambertin	5357
2015		1998	
Domaine Bouchard Père & Fils, Corton-Charlemagne	5322	Domaine Leroy, Clos de Vougeot	5346
Domaine de Montille, Puligny-Montrachet Le Cailleret	5561	Georges Roumier, Musigny	5453
Domaine Faiveley, Corton-Charlemagne	5519	1999	
Maison de Montille, Meursault Les Porusots	5560	Domaine de la Romanée-Conti, Romanée-Conti	5234
2016		Domaine Leroy, Chambolle-Musigny Les Charmes	5379
Domaine de Montille, Corton-Charlemagne	5558-5559	Domaine Leroy, Clos de la Roche	5355
Domaine Faiveley, Meursault Charmes	5520	Domaine Leroy, Clos de Vougeot	5347
MIXED		Domaine Leroy, Latricières-Chambertin	5358
Mixed Coche Dury, Meursault	5131	Dugat-Py, Chambertin	5446
Mixed Coche Dury, Puligny-Meursault	5132	Georges Roumier, Musigny	5454
Mixed Coche Dury, Puligny-Montrachet Les Enseignères	5133	Henri Mayer, Vosne-Romanée Cros Parantoux	5457
Mixed Joseph Drouhin, Marquis de Laguiche Montrachet	5324	Maison Leroy, Meursault-Blagny Premier Cru	5261
Mixed Pierre-Yves Colin-Morey, Saint-Aubin	5466	2000	
RED BURGUNDY		Domaine d'Auvenay, Bonnes-Mares	5247-5248
1961		Domaine d'Auvenay, Mazis-Chambertin	5244-5245
Domaine de la Romanée-Conti, Richebourg	5506	Domaine Leroy, Latricières-Chambertin	5359
Pommery, Cuvée Spéciale	5624	Domaine Leroy, Richebourg	5365
1962		2001	
Domaine de la Romanée-Conti, Grands-Echézeaux	5508	Domaine Armand Rousseau, Chambertin	5124
1966		Domaine d'Auvenay, Bonnes-Mares	5249
Domaine de la Romanée-Conti, Richebourg	5507	Domaine d'Auvenay, Mazis-Chambertin	5246
Ropiteau Frères, Volnay Clos des Chênes	5768	Domaine de la Romanée-Conti, Romanée-Conti	5103
1978		Domaine de la Romanée-Conti, Romanée-Saint-Vivant	5120
Domaine de la Romanée-Conti, Romanée-Conti	5231-5232	Domaine Leroy, Clos de Vougeot	5348
1982		2002	
Château de Pommard Pommard Cuvée Jean-Louis Laplanche	5059	Domaine Armand Rousseau, Chambertin	5125
1985		Domaine Comte Georges de Vogüé, Bonnes-Mares	5269
Henri Mayer, Richebourg	5455	Domaine Comte Georges de Vogüé, Musigny Vieilles Vignes	5262, 5270
Henri Mayer, Echézeaux	5456	Domaine de la Romanée-Conti, La Tâche	5237
1988		Domaine Dugat-Py, Chambertin	5057
Domaine de la Romanée-Conti, Romanée-Saint-Vivant	5240	Domaine Leroy, Clos de Vougeot	5349
1989		Domaine Leroy, Vosne-Romanée Les Beaux Monts	5376
Domaine de la Romanée-Conti, La Tâche	5277	2003	
Domaine de la Romanée-Conti, Romanée-Conti	5101	Domaine de la Romanée-Conti, La Tâche	5238-5239
Domaine Leroy, Clos de Vougeot	5343	Domaine de la Romanée-Conti, Romanée-Conti	5235-5236
Domaine Leroy, Vosne-Romanée Les Beaux Monts	5281	Domaine Leroy, Latricières-Chambertin	5360
1990		2004	
Domaine de la Romanée-Conti, Romanée-Conti	5233	Domaine Armand Rousseau, Chambertin	5433
Domaine Leroy, Clos de Vougeot	5075, 5344	Domaine Armand Rousseau, Ruchottes-Chambertin	
Domaine Leroy, Romanée-Saint-Vivant	5368	Clos des Ruchottes	5434
Domaine Leroy, Vosne-Romanée Les Brûlées	5373	Domaine Faiveley, Nuits St. Georges Aux Chaignots	5532
Maison Leroy, Musigny	5422	2005	
1991		Domaine Comte Georges de Vogüé, Musigny Vieilles Vignes	5263
Domaine de la Romanée-Conti, Richebourg	5278	Domaine Dugat-Py, Chambertin	5058
Domaine de la Romanée-Conti, Romanée-Saint-Vivant	5280	Domaine Leroy, Latricières-Chambertin	5361
1992		2006	
Domaine de la Romanée-Conti, Richebourg	5279	Domaine de la Romanée-Conti, Richebourg	5114
Domaine Leroy, Richebourg	5364	Domaine de la Romanée-Conti, Romanée-Conti	5104
Domaine Leroy, Romanée-Saint-Vivant	5369	Domaine de la Romanée-Conti, Romanée-Saint-Vivant	5056
1993		Domaine Faiveley, Corton Clos des Cortons	5525
Domaine Leroy, Romanée-Saint-Vivant	5370	Domaine Leroy, Chambertin	5250
		2007	
		Domaine de la Romanée-Conti, Echézeaux	5111
		Domaine de la Romanée-Conti, La Tâche	5106

Index by Vintage

WINE	Lot No.	WINE	Lot No.
Domaine de la Romanée-Conti, Richebourg	5115	2012	
Domaine Faiveley, Nuits St. Georges Les Damodes	5533	Bruno Clair, Savigny-lès-Beaune La Dominode	5493
Domaine Leroy, Chambertin	5251	Domaine de la Romanée-Conti, Echézeaux	5113
Domaine Leroy, Chambolle-Musigny Les Fremières	5385	Domaine de la Romanée-Conti, Romanée-Conti	5105
Domaine Leroy, Corton Renardes	5335	Domaine Denis Mortet, Clos de Vougeot	5136
Domaine Leroy, Gevrey-Chambertin Les Combottes	5381	Domaine Ponsot, Clos de la Roche Vieilles Vignes	5581
Domaine Leroy, Musigny	5255	Domaine de la Romanée-Conti, Assortment	5122
Domaine Leroy, Nuits-Saint-Georges Aux Allots	5387	Lucien Le Moine, Chambolle-Musigny Les Groseilles	5544
Domaine Leroy, Nuits-Saint-Georges Aux Boudots	5389	Lucien Le Moine, Charmes-Chambertin	5541
Domaine Leroy, Vosne-Romanée Les Brûlées	5374	2013	
2008		Domaine de la Romanée-Conti, La Tâche	5109
Domaine Armand Rousseau, Chambertin	5126	Domaine de la Romanée-Conti, Richebourg	5119
Domaine de la Romanée-Conti, Richebourg	5116	Domaine de la Romanée-Conti, Romanée-Saint-Vivant	5121
Domaine Leroy, Chambertin	5252	Dujac Fils et Père, Clos de la Roche	5515
Domaine Leroy, Clos de Vougeot	5350	Dujac Fils et Père, Nuits St. Georges Les Damodes	5517
Domaine Leroy, Corton Renardes	5336-5337	Henri Boillot, Clos de Vougeot	5492
Domaine Leroy, Musigny	5256	Henri Boillot, Pommard Les Rugiens	5489
Domaine Leroy, Richebourg	5258	J.F. Mugnier, Chambolle-Musigny Les Fuées	5539
Domaine Leroy, Romanée-Saint-Vivant	5260	Jean-Jacques Confuron, Clos de Vougeot	5503-5504
2009		Lucien Le Moine, Chambertin-Clos de Bèze	5542
Christian Confuron & Fils, Musigny	5495	Olivier Bernstein, Clos de Vougeot	5575-5576
Domaine de la Romanée-Conti, Echézeaux	5112	Olivier Bernstein, Gevrey Chambertin Les Champeaux	5578-5579
Domaine de la Romanée-Conti, La Tâche	5107	2014	
Domaine de la Romanée-Conti, Richebourg	5117	Bruno Clair, Gevrey Chambertin	5494
Domaine Faiveley, Mazis-Chambertin	5326	Arnoux Lachaux, Chambolle-Musigny	5488
Domaine Leroy, Chambertin	5253	Domaine Armand Rousseau, Chambertin	5127
Domaine Leroy, Clos de Vougeot	5351	Domaine de la Romanée-Conti, La Tâche	5110
Domaine Leroy, Musigny	5257	Domaine de la Romanée-Conti, Romanée-Saint-Vivant	5451
Domaine Leroy, Richebourg	5259	Domaine de Montille, Volnay Les Mitans	5564
Domaine Leroy, Vosne-Romanée Les Beaux Monts	5377	Domaine de Montille, Vosne-Romanée Les Malconsorts	5570
Domaine Perrot-Minot, Nuits-Saint-Georges Les Cras Vieilles Vignes	5435	Domaine Faiveley, Latricieres-Chambertin	5528-5529
Domaine Perrot-Minot, Nuits-Saint-Georges Les Murgers		Domaine Ponsot, Charmes-Chambertin Cuvée des Merles	5582
Vieilles Vignes	5436	Domaine Prieuré Roch, Chambertin-Clos de Bèze	5327
2010		Domaine Prieuré Roch, Clos de Vougeot	5328
Christian Confuron & Fils, Musigny	5496	Domaine Prieuré Roch, Vosne-Romanée Les Suchots	5329
Domaine Armand Rousseau, Chambertin-Clos de Bèze	5267	Dugat-Py, Gevrey Chambertin Cœur de Roy	5510-5511
Domaine de la Romanée-Conti, La Tâche	5108	Dugat-Py, Gevrey Chambertin Vieilles Vignes	5513
Domaine de la Romanée-Conti, Richebourg	5118	François Raveneau, Chablis Grand Cru Blanchot	5465
Domaine Faiveley, Nuits St. Georges Les Porêts Saint-Georges	5534	Henri Boillot, Pommard Les Rugiens	5490
Domaine Leroy, Clos de Vougeot	5352	Jean-Jacques Confuron, Chambolle-Musigny	5505
2011		Lucien Le Moine, Clos St. Denis	5543
Arnoux Lachaux, Nuits St. Georges Clos des Corvées Pagets	5486	Lucien Le Moine, Nuits St. Georges Les Vaucrains	5545
Domaine Leroy, Chambertin	5342	Marquis d'Angerville, Volnay Caillerets	5482
Domaine Leroy, Chambolle-Musigny Les Charmes	5380	Marquis d'Angerville, Volnay Champans	5481
Domaine Leroy, Chambolle-Musigny Les Fremières	5386	Michel Magnien, Clos Saint Denis	5553
Domaine Leroy, Clos de la Roche	5356	Michel Magnien, Gevrey Chambertin Les Cazetiers	5555
Domaine Leroy, Clos de Vougeot	5353	Michel Magnien, Morey-Saint-Denis Les Millandes	5557
Domaine Leroy, Corton Renardes	5338	Mommessin, Clos de Tart	5499-5500
Domaine Leroy, Latricières-Chambertin	5362	Olivier Bernstein, Charmes-Chambertin	5572-5573
Domaine Leroy, Musigny	5363	Olivier Bernstein, Clos de la Roche	5574
Domaine Leroy, Nuits-Saint-Georges Aux Allots	5388	2015	
Domaine Leroy, Nuits-Saint-Georges Aux Boudots	5390	Arnoux Lachaux, Clos Vougeot	5485
Domaine Leroy, Nuits-Saint-Georges Aux Lavières	5391	Domaine de L'Arlet, Nuits St. Georges Clos des Forets St. Georges	5483
Domaine Leroy, Pommard Les Vignots	5341	Domaine de Montille, Beaune Les Sizie	5567
Domaine Leroy, Richebourg	5366	Domaine des Comtes Lafon, Volnay Santenots-du-Milieu	5502
Domaine Leroy, Richebourg	5367	Domaine Faiveley, Chambolle-Musigny Aux Beaux Bruns	5536
Domaine Leroy, Romanée-Saint-Vivant	5371-5372	Domaine Faiveley, Chambolle-Musigny Les Charmes	5537
Domaine Leroy, Savigny-lès-Beaune Les Narbantons	5340	Domaine Faiveley, Clos Saint-Denis	5325
Domaine Leroy, Volnay Santenots du Milieu	5339	DRC Assortment	5123
Domaine Leroy, Vosne-Romanée Les Beaux Monts	5378	Henri Boillot, Volnay Les Chevrets	5491
Domaine Leroy, Vosne-Romanée Les Genavrières	5382	Lucien Le Moine, Morey St. Denis Les Genavrières	5546
Dugat-Py, Gevrey Chambertin Champeaux	5509	Michel Magnien, Clos de la Roche	5550
Dugat-Py, Gevrey Chambertin Vieilles Vignes	5512	Michel Magnien, Morey-Saint-Denis Les Chaffots	5556
Lucien Le Moine, Pommard Les Epenots	5540	2016	
Mommessin, Clos de Tart	5497-5498	Arnoux Lachaux, Vosne-Romanée Les Chaumes	5487

Index by Vintage

WINE	Lot No.	WINE	Lot No.
Domaine de Montille, Clos Vougeot	5568	2009	
Domaine de Montille, Corton Clos du Roi	5562-5563	Château de Beaucastel, Châteauneuf-du-Pape Hommage à Jacques Perrin	5146-5147
Domaine de Montille, Nuits St. Georges Aux Thorey	5569	2012	
Domaine de Montille, Pommard Les Rugiens-Bas	5566	Château de Beaucastel, Châteauneuf-du-Pape Hommage à Jacques Perrin	5148
Domaine de Montille, Volnay Les Taillepieds	5565	2014	
Domaine Dujac, Morey St.Denis 1er Cru	5514	Château de Beaucastel, Châteauneuf-du-Pape Hommage à Jacques Perrin	5150
Domaine Faiveley, Charmes Chambertin	5522	2015	
Domaine Faiveley, Clos de Vougeot	5523-5524	Château de Beaucastel, Châteauneuf-du-Pape Hommage à Jacques Perrin	5151-5155
Domaine Faiveley, Corton Clos des Cortons	5526-5527	Château Grillet	5583
Domaine Faiveley, Gevrey-Chambertin Clos des Issarts	5530	MIXED	
Domaine Faiveley, Gevrey-Chambertin La Combe aux Moines	5531	Mixed M. Chapoutier, Ermitage Le Meal Blanc & Rouge	5054
Domaine Faiveley, Nuits St. Georges Les Porêts Saint-Georges	5535	Mixed Rhône	5055
Domaine Faiveley, Volnay Santenots	5521	Mixed E. Guigal, Côte-Rôtie La Landonne	5138
Domaine Ponsot, Corton-Charlemagne	5580	Mixed E. Guigal, Côte-Rôtie La Mouline	5139
Dujac Fils et Père, Clos de la Roche	5516	Mixed E. Guigal, Côte-Rôtie La Turque	5140
J.F. Mugnier, Nuits St. Georges Clos de la Maréchale Rouge	5538	Mixed Château de Beaucastel, Châteauneuf-du-Pape Blanc	5141
Lucien Le Moine, Gevrey Chambertin Les Champeaux	5547	Mixed Château de Beaucastel	5142
Michel Magnien, Charmes-Chambertin	5548-5549	Mixed Château de Beaucastel, Châteauneuf-du-Pape Hommage à Jacques Perrin	5143
Michel Magnien, Clos de la Roche	5551-5552	Mixed Formats of Château de Beaucastel, Châteauneuf-du-Pape Hommage à Jacques Perrin	5149
Michel Magnien, Clos Saint Denis	5554	Mixed Henri Bonneau, Châteauneuf-du-Pape Réserve de Célestins	5159
Michel Niellon, Chassagne-Montrachet Clos St. Jean Rouge	5571	Mixed Domaine Jean-Louis Chave, Hermitage Blanc	5161
Olivier Bernstein, Chambolle-Musigny Les Lavrottes	5577	Mixed Domaine Jean-Louis Chave, Hermitage Rouge	5162
MIXED		Mixed Domaine Jean-Louis Chave, Hermitage Blanc & Rouge	5163
Mixed Burgundy	5060	GERMANY	
Mixed Domaine Armand Rousseau, Clos des Ruchottes	5128	1983	
Mixed Domaine Armand Rousseau, Mazy & Charmes-Chambertin	5129	JJ Prüm, Wehlener Sonnenuhr Eiswein	5164
Mixed Domaine Armand Rousseau	5130	1988	
Mixed Mommessin, Clos de Tart	5134	JJ Prüm, Zeltinger Sonnenuhr Auslese	5166
Mixed Burgundy	5135	1989	
Mixed Domaine Armand Rousseau, Clos Saint Jacques in Magnums	5268	Egon Müller, Scharzhofberger Auslese	5177
Mixed Domaine Leroy	5283	1990	
Mixed 1999 & 2003 Emmanuel Rouget, Vosne-Romanée Cros Parantoux	5443	Egon Müller, Scharzhofberger Beerenauslese	5179
Mixed 1997 & 1999 Emmanuel Rouget, Echézeaux	5444	1991	
Mixed 2000 & 2002 Emmanuel Rouget, Echézeaux	5445	Egon Müller, Scharzhofberger Auslese	5180
Mixed 1990s Dugat-Py, Charmes-Chambertin	5447	1992	
Mixed Domaine de L'Arlot	5484	Egon Müller, Scharzhofberger Eiswein	5182
Mixed Arnaud Ente, Meursault Clos des Ambres	5518	JJ Prüm, Wehlener Sonnenuhr Auslese Goldkapsel	5167
Mixed Beaune from Bouchard & Patriarche Père & Fils	5767	1993	
RHÔNE		Egon Müller, Scharzhofberger Beerenauslese	5184
1969		1995	
Paul Jaboulet Aîné, Hermitage La Chapelle	5448	Egon Müller, Scharzhofberger Auslese	5186
1974		1996	
Domaine de la Romanée-Conti, Romanée-Conti	5100	Egon Müller, Scharzhofberger Auslese	5188
1983		Egon Müller, Scharzhofberger Eiswein	5187
Paul Jaboulet, Hermitage La Chapelle	5773-5781	1997	
1998		JJ Prüm, Wehlener Sonnenuhr Auslese	5169
M. Chapoutier, Châteauneuf-du-Pape Barbe Rac	5437	1998	
1999		JJ Prüm, Wehlener Sonnenuhr Auslese Goldkapsel	5170
Henri Bonneau, Châteauneuf-du-Pape Marie Beurrier	5156	1999	
2000		Egon Müller, Scharzhofberger Auslese	5190
Henri Bonneau, Châteauneuf-du-Pape Réserve de Célestins	5157	JJ Prüm, Wehlener Sonnenuhr Auslese Goldkapsel	5171
Domaine Jean-Louis Chave, Ermitage Cuvée Cathelin	5160	MIXED	
M. Chapoutier, Châteauneuf-du-Pape Barbe Rac	5438	Mixed 1985 JJ Prüm	5165
2003		Mixed 1994 JJ Prüm	5168
E. Guigal, Ermitage Ex-Voto	5137	Mixed 1976 Egon Müller & JJ Prüm	5172
M. Chapoutier, Ermitage Le Pavillon	5052	Mixed Egon Müller & JJ Prüm	5173
2006		Mixed 1993 Egon Müller & JJ Prüm	5174
M. Chapoutier, Ermitage Les Greffieux	5053	Mixed 1975 Egon Müller	5175
2007			
Château de Beaucastel, Châteauneuf-du-Pape Hommage à Jacques Perrin	5144-5145		
Clos des Papes, Châteauneuf-du-Pape	5439		
Henri Bonneau, Châteauneuf-du-Pape Réserve de Célestins	5158		

Index by Vintage

WINE	Lot No.	WINE	Lot No.
Mixed 1989 Egon Müller	5176	1860	
Mixed 1990 & 1991 Egon Müller	5178	Cunha, Bual Velho	5200-5203
Mixed Formats of 1992 Egon Müller, Scharzhofberger		Torre Bella, Terrantez	5204
Auslese Goldkapsel	5181	Believed 1893	
Mixed 1993 Egon Müller	5183	Malvasia M Velha	5209-5210
Mixed 1994 Egon Müller	5185	1933	
Mixed 1997 Egon Müller	5189	Boal Campanario	5205-5206
J.J. Prüm 2005 Auslese & Goldkapsel	5276	1934	
		FEM, Verdelho	5207-5208
ITALY		MIXED	
1998		Mixed Quinta do Noval	5601
Sassicaia	5271-5272		
2001		HUNGARY	
Sassicaia	5273-5274	Oremus, Tokaji Eszencia	5600
2007			
Gaja, Ca' Marcanda, Camarcanda	5275	USA	
2012		1992	
Cerbaiona, Brunello di Montalcino	5584	Screaming Eagle	5459
2013		2012	
Gaja, Darmagi	5591-5592	Araujo, Altigracia Cabernet Sauvignon	5610
Gaja, Pieve di Santa Restituta Brunello di Montalcino Rennina	5593-5594	Screaming Eagle	5622
Gaja, Pieve di Santa Restituta Brunello di Montalcino Sugaril	5595	2013	
2014		Colgin, IX Estate	5616
Gaja, Costa Russi	5586	2014	
Gaja, Sori San Lorenzo	5587-5588	Bond, Melbury	5612
Gaja, Sori Tildin	5589-5590	Bond, Quella	5613
2015		Dana Estate, Helms Vineyard Cabernet Sauvignon	5617
Gaja, Barolo Dagromis	5585	Dana Estate, Onda Cabernet Sauvignon	5619-5620
Gaja, Ca' Marcanda Camarcanda	5596	Eisele Vineyard, Altigracia Cabernet Sauvignon	5611
Sassicaia	5330	Eisele Vineyard, Cabernet Sauvignon	5608-5609
Tenuta dell'Ornellaia, Le Serre Nuove	5598	Screaming Eagle	5623
Tenuta dell'Ornellaia, Ornellaia	5597	2015	
2016		Bond, St. Eden	5614
Tenuta dell'Ornellaia, Le Serre Nuove	5599	Bond, Vecina	5615
MIXED		Dana Estate, Hershey Vineyard Cabernet Sauvignon	5618
Mixed Italy	5061	2016	
Mixed G. Conterno and Masseto	5458	Kistler, Laguna Ridge Vineyard Pinot Noir	5462
Mixed Soldera, Brunello di Montalcino	5467	Screaming Eagle, Sauvignon Blanc	5621
		MIXED	
SPAIN		Kistler, Cuvée Natalie Pinot Noir Vertical	5463
2004		Kistler, Hyde Vineyard Chardonnay Vertical	5460
Vega Sicilia, Alion	5440	Kistler, Kistler Vineyard Chardonnay Vertical	5461
2006		Mixed Sine Qua Non	5062
Vega Sicilia Unico	5602-5603	AUSTRALIA	
2007		2000	
Vega Sicilia Unico	5331	Clarendon Hills, Astralis	5430
2013		MIXED	
Vega Sicilia, Valbuena 5°	5606	Mixed Penfolds Grange	5063
2014			
Vega Sicilia, Alion	5607	WHISKY	
NV		1967	
Vega Sicilia Unico Reserva Especial	5449, 5468, 5604-5605	The Glenlivet 50 Year-Old Winchester Collection	5392
PORTUGAL		1990	
1801		The Cask of Yamazaki 1990	5398
Torre Bella, Terrantez Private Stock	5191	1991	
1811		Yamazaki Vintage Malt 1991	5397
Torre Bella, Verdelho Private Stock	5192-5193	Suntory Yamazaki 1991	5401
1830		1999	
Cunha, Sercial	5194	Suntory Yamazaki 1999	5402
JCS Estreito, Pico e Salões, Câmara de Lobos, Verdelho Antigo	5195-5196	NV	
1838		The Macallan 25 Years	5393
Bual Campanario	5197-5198	The Macallan 25 Years Decanter	5394
1840		Ichiro's Malt Hanyu Card Joker	5395
Perestrello, Terrantez	5199	"Hakushu 25 Year Limited Edition 白州25年限定版"	5396

Index by Vintage

WINE	Lot No.
Nikka Whisky 35 Year	5399-5400
Karuizawa "Aqua of Life" 50 Year Old	5403
Karuizawa 1969	5404
Karuizawa 1981 Miyajima	5405
Karuizawa Cask Strength 1st, 2nd, 3rd and 4th Release	5406
Karuizawa - Golden House with 5 Mistresses	5407
Karuizawa 36 Views Of Mount Fuji Batch 1-28	5408
Royal Household Scotch Whisky	5423-5429
DECANTER ASIA WINE AWARDS 2019	
Bordeaux	5782-5784
Tuscany	5785-5790
Piedmont	5791-5795
Veneto	5796-5801
Spain	5802-5814
Victoria, Tasmania & Western Australia	5815-5821
South & South Eastern Australia	5822-5829
New Zealand	5830-5835
North America	5836-5839

CONDITIONS OF SALE • BUYING AT CHRISTIE'S

CONDITIONS OF SALE

These Conditions of Sale and the Important Notices and Explanation of Cataloguing Practice set out the terms on which we offer the **lots** listed in this catalogue for sale. By registering to bid and/or by bidding at auction you agree to these terms, so you should read them carefully before doing so. You will find a glossary at the end explaining the meaning of the words and expressions coloured in **bold**.

Unless we own a **lot** (▲ symbol), Christie's acts as agent for the seller.

A BEFORE THE SALE

1 DESCRIPTION OF LOTS

(a) Certain words used in the catalogue description have special meanings. You can find details of these on the page headed "Important Notices and Explanation of Cataloguing Practice" which forms part of these terms. You can find a key to the Symbols found next to certain catalogue entries under the section of the catalogue called "Symbols Used in this Catalogue".

(b) Our description of any **lot** in the catalogue, any **condition** report and any other statement made by us (whether orally or in writing) about any **lot**, including about its nature or **condition**, artist, period, materials, approximate dimensions or **provenance** are our opinion and not to be relied upon as a statement of fact. We do not carry out in-depth research of the sort carried out by professional historians and scholars. All dimensions and weights are approximate only.

2 OUR RESPONSIBILITY FOR OUR DESCRIPTION OF LOTS

We do not provide any guarantee in relation to the nature of a **lot** apart from our **authenticity warranty** contained in paragraph E2 and to the extent provided in paragraph I below.

3 CONDITION

(a) The **condition** of **lots** sold in our auctions can vary widely due to factors such as age, previous damage, restoration, repair and wear and tear. Their nature means that they will rarely be in perfect **condition**. **Lots** are sold "as is" in the **condition** they are in at the time of the sale, without any representation or warranty or assumption of liability of any kind as to **condition** by Christie's or by the seller.

(b) Any reference to **condition** in a catalogue entry or in a **condition** report will not amount to a full description of **condition**, and images may not show a **lot** clearly. Colours and shades may look different in print or on screen to how they look on physical inspection. **Condition** reports may be available to help you evaluate the **condition** of a **lot**. **Condition** reports are provided free of charge as a convenience to our buyers and are for guidance only. They offer our opinion but they may not refer to all faults, inherent defects, restoration, alteration or adaptation because our staff are not professional restorers or conservators. For that reason they are not an alternative to examining a **lot** in person or taking your own professional advice. It is your responsibility to ensure that you have requested, received and considered any **condition** report.

4 VIEWING LOTS PRE-AUCTION

(a) If you are planning to bid on a **lot**, you should inspect it personally or through a knowledgeable representative before you make a bid to make sure that you accept the description and its **condition**. We

recommend you get your own advice from a restorer or other professional adviser.

(b) Pre-auction viewings are open to the public free of charge. Our specialists may be available to answer questions at pre-auction viewings or by appointment.

5 ESTIMATES

Estimates are based on the **condition**, rarity, quality and **provenance** of the **lots** and on prices recently paid at auction for similar property. **Estimates** can change. Neither you, nor anyone else, may rely on any **estimates** as a prediction or guarantee of the actual selling price of a **lot** or its value for any other purpose. **Estimates** do not include the **buyer's premium** or any applicable taxes. **Estimates** may be shown in different currencies from that of the saleroom for guidance only. The rate of exchange used in our printed catalogues is fixed at the latest practical date prior to the printing of the catalogue and may have changed by the time of our sale.

6 WITHDRAWAL

Christie's may, at its option, withdraw any **lot** at any time prior to or during the sale of the **lot**. Christie's has no liability to you for any decision to withdraw.

7 JEWELLERY

(a) Coloured gemstones (such as rubies, sapphires and emeralds) may have been treated to improve their look, through methods such as heating and oiling. These methods are accepted by the international jewellery trade but may make the gemstone less strong and/or require special care over time.

(b) All types of gemstones may have been improved by some method. You may request a gemmological report for any item which does not have a report if the request is made to us at least three weeks before the date of the auction and you pay the fee for the report.

(c) We do not obtain a gemmological report for every gemstone sold in our auctions. Where we do get gemmological reports from internationally accepted gemmological laboratories, such reports will be described in the catalogue. Reports from American gemmological laboratories will describe any improvement or treatment to the gemstone. Reports from European gemmological laboratories will describe any improvement or treatment only if we request that they do so, but will confirm when no improvement or treatment has been made. Because of differences in approach and technology, laboratories may not agree whether a particular gemstone has been treated, the amount of treatment or whether treatment is permanent. The gemmological laboratories will only report on the improvements or treatments known to the laboratories at the date of the report.

(d) For jewellery sales, **estimates** are based on the information in any gemmological report or, if no report is available, assume that the gemstones may have been treated or enhanced.

8 WATCHES & CLOCKS

(a) Almost all clocks and watches are repaired in their lifetime and may include parts which are not original. We do not give a **warranty** that any individual component part of any watch or clock is **authentic**. Watchbands described as "associated" are not part of the original watch and may not be **authentic**. Clocks may be sold without pendulums, weights or keys.

(b) As collectors' watches and clocks often have very fine and complex mechanisms, a general service, change of battery or further repair work may be

necessary, for which you are responsible. We do not give a **warranty** that any watch or clock is in good working order. Certificates are not available unless described in the catalogue.

(c) Most watches have been opened to find out the type and quality of movement. For that reason, watches with water resistant cases may not be waterproof and we recommend you have them checked by a competent watchmaker before use.

Important information about the sale, transport and shipping of watches and watchbands can be found in paragraph H2(f).

B REGISTERING TO BID

1 NEW BIDDERS

(a) If this is your first time bidding at Christie's or you are a returning bidder who has not bought anything from any of our salerooms within the last two years you must register at least 48 hours before an auction to give us enough time to process and approve your registration. We may, at our option, decline to permit you to register as a bidder. You will be asked for the following:

(i) for individuals: Photo identification (driving licence, national identity card or passport) and, if not shown on the ID document, proof of your current address (for example, a current utility bill or bank statement);

(ii) for corporate clients: Your Certificate of Incorporation or equivalent document(s) showing your name and registered address, photo ID copy of the authorized bidder, letter of authorization duly signed by legal representative and, where applicable, chopped with company stamp and together with documentary proof of directors and beneficial owners;

(iii) for trusts, partnerships, offshore companies and other business structures, please contact us in advance to discuss our requirements.

(b) We may also ask you to give us a financial reference and/or a deposit as a condition of allowing you to bid. For help, please contact our Client Services Department on +852 2760 1766.

2 RETURNING BIDDERS

We may at our option ask you for current identification as described in paragraph B1(a) above, a financial reference or a deposit as a condition of allowing you to bid. If you have not bought anything from any of our salerooms in the last two years or if you want to spend more than on previous occasions, please contact our Bids Department on +852 2978 9910 or email to bidsasia@christies.com.

3 IF YOU FAIL TO PROVIDE THE RIGHT DOCUMENTS

If in our opinion you do not satisfy our bidder identification and registration procedures including, but not limited to completing any anti-money laundering and/or anti-terrorism financing checks we may require to our satisfaction, we may refuse to register you to bid, and if you make a successful bid, we may cancel the contract for sale between you and the seller. Christie's may, at its option, specify the type of photo identification it will accept, for the purposes of bidder identification and registration procedures.

4 BIDDING ON BEHALF OF ANOTHER PERSON

(a) **As authorised bidder:** If you are bidding on behalf of another person, that person will need to complete the registration requirements above before you can bid, and supply a signed letter authorising you to bid for him/her.

(b) **As agent for an undisclosed principal:** If you are bidding as an agent for an undisclosed principal (the ultimate buyer(s)), you accept personal liability to pay the **purchase price** and all other sums due. Further, you warrant that:

(i) you have conducted appropriate customer due diligence on the ultimate buyer(s) of the **lot(s)** in accordance with any and all applicable anti-money laundering and sanctions laws, consent to us relying on this due diligence, and you will retain for a period of not less than 5 years the documentation and records evidencing the due diligence;

(ii) you will make such documentation and records evidencing your due diligence promptly available for immediate inspection by an independent third-party auditor upon our written request to do so. We will not disclose such documentation and records to any third-parties unless (1) it is already in the public domain, (2) it is required to be disclosed by law, or (3) it is in accordance with anti-money laundering laws;

(iii) the arrangements between you and the ultimate buyer(s) are not designed to facilitate tax crimes;

(iv) you do not know, and have no reason to suspect, that the funds used for settlement are connected with, the proceeds of any criminal activity or that the ultimate buyer(s) are under investigation, charged with or convicted of money laundering, terrorist activities or other money laundering predicate crimes.

A bidder accepts personal liability to pay the **purchase price** and all other sums due unless it has been agreed in writing with Christie's before commencement of the auction that the bidder is acting as an agent on behalf of a named third party acceptable to Christie's and that Christie's will only seek payment from the named third party.

5 BIDDING IN PERSON

If you wish to bid in the saleroom you must register for a numbered bidding paddle at least 30 minutes before the auction. For help, please contact the Client Services Department on +852 2760 1766.

6 BIDDING SERVICES

The bidding services described below are a free service offered as a convenience to our clients and Christie's is not responsible for any error (human or otherwise), omission or breakdown in providing these services.

(a) Phone Bids

Your request for this service must be made no later than 24 hours prior to the auction. We will accept bids by telephone for **lots** only if our staff are available to take the bids. Telephone bids cannot be accepted for lots estimated below HK\$30,000. If you need to bid in a language other than in English, you must arrange this well before the auction. We may record telephone bids. By bidding on the telephone, you are agreeing to us recording your conversations. You also agree that your telephone bids are governed by these Conditions of Sale.

(b) Internet Bids on Christie's Live™

For certain auctions we will accept bids over the Internet. Please visit www.christies.com/livebidding and click on the 'Bid Live' icon to see details of how to watch, hear and bid at the auction from your computer. As well as these Conditions of Sale, internet bids are governed by the Christie's LIVE™ terms of use which are available on www.christies.com.

(c) Written Bids

You can find a Written Bid Form at the back of our catalogues, at any Christie's office or by choosing the sale and viewing the **lots** online at www.christies.com. We must receive your completed Written Bid Form at least 24 hours before the auction. Bids must be placed in the currency of the saleroom. The **auctioneer** will take reasonable steps to carry out written bids at the lowest possible price, taking into account the **reserve**.

If you make a written bid on a **lot** which does not have a **reserve** and there is no higher bid than yours, we will bid on your behalf at around 50% of the **low estimate** or, if lower, the amount of your bid. If we receive written bids on a **lot** for identical amounts, and at the auction these are the highest bids on the **lot**, we will sell the **lot** to the bidder whose written bid we received first.

C CONDUCTING THE SALE

1 WHO CAN ENTER THE AUCTION

We may, at our option, refuse admission to our premises or decline to permit participation in any auction or to reject any bid.

2 RESERVES

Unless otherwise indicated, all **lots** are subject to a **reserve**. We identify **lots** that are offered without **reserve** with the symbol • next to the **lot** number. The **reserve** cannot be more than the **lot's low estimate**.

3 AUCTIONEER'S DISCRETION

The **auctioneer** can at his sole option:

(a) refuse any bid;

(b) move the bidding backwards or forwards in any way he or she may decide, or change the order of the **lots**;

(c) withdraw any **lot**;

(d) divide any **lot** or combine any two or more **lots**;

(e) reopen or continue the bidding even after the hammer has fallen; and

(f) in the case of error or dispute related to bidding and whether during or after the auction, continue the bidding, determine the successful bidder, cancel the sale of the **lot**, or reoffer and resell any **lot**. If you believe that the **auctioneer** has accepted the successful bid in error, you must provide a written notice detailing your claim within 3 business days of the date of the auction. The **auctioneer** will consider such claim in good faith. If the **auctioneer**, in the exercise of his or her discretion under this paragraph, decides after the auction is complete, to cancel the sale of a **lot**, or reoffer and resell a **lot**, he or she will notify the successful bidder no later than by the end of the 7th calendar day following the date of the auction. The **auctioneer's** decision in exercise of this discretion is final. This paragraph does not in any way prejudice Christie's ability to cancel the sale of a **lot** under any other applicable provision of these Conditions of Sale, including the rights of cancellation set forth in sections B(3), E(2)(i), F(4), and J(1).

4 BIDDING

The **auctioneer** accepts bids from:

(a) bidders in the saleroom;

(b) telephone bidders, and internet bidders through 'Christie's LIVE™' (as shown above in Section B6); and

(c) written bids (also known as absentee bids or commission bids) left with us by a bidder before the auction.

5 BIDDING ON BEHALF OF THE SELLER

The **auctioneer** may, at his or her sole option, bid on behalf of the seller up to but not including the amount of the **reserve** either by making consecutive bids or by making bids in response to other bidders. The **auctioneer** will not identify these as bids made on behalf of the seller and will not make any bid on behalf of the seller at or above the **reserve**. If **lots** are offered without **reserve**, the **auctioneer** will generally decide to open the bidding at 50% of the **low estimate** for the **lot**. If no bid is made at that level, the **auctioneer** may decide to go backwards at his or her sole option until a bid is made, and then continue up from that amount. In the event that there are no bids on a **lot**, the **auctioneer** may deem such **lot** unsold.

6 BID INCREMENTS

Bidding generally starts below the **low estimate** and increases in steps (bid increments). The **auctioneer** will decide at his or her sole option where the bidding should start and the bid increments. The usual bid increments are shown for guidance only on the Written Bid Form at the back of this catalogue.

7 CURRENCY CONVERTER

The saleroom video screens, Christie's LIVE™ and Christie's website may show bids in some other major currencies from that of the saleroom. Any conversion is for guidance only and we cannot be bound by any rate of exchange used by Christie's. Christie's is not responsible for any error (human or otherwise), omission or breakdown in providing these services.

8 SUCCESSFUL BIDS

Unless the **auctioneer** decides to use his or her discretion as set out in paragraph C3 above, when the **auctioneer's** hammer strikes, we have accepted the last bid. This means a contract for sale has been formed between the seller and the successful bidder. We will issue an invoice only to the registered bidder who made the successful bid. While we send out invoices by post and/or email after the auction, we do not accept responsibility for telling you whether or not your bid was successful. If you have bid by written bid, you should contact us by telephone or in person as soon as possible after the auction to get details of the outcome of your bid to avoid having to pay unnecessary storage charges.

9 LOCAL BIDDING LAWS

You agree that when bidding in any of our sales that you will strictly comply with all local laws and regulations in force at the time of the sale for the relevant sale site.

D THE BUYER'S PREMIUM, TAXES

1 THE BUYER'S PREMIUM

In addition to the **hammer price**, the successful bidder agrees to pay us a **buyer's premium** on the **hammer price** of each **lot** sold. On all **lots** we charge 25% of the **hammer price** up to and including HK\$2,500,000, 20% on that part of the **hammer price** over HK\$2,500,000 and up to and including HK\$30,000,000, and 13.5% of that part of the **hammer price** above HK\$30,000,000.

2 TAXES

The successful bidder is responsible for any applicable tax including any VAT, sales or compensating use tax or equivalent tax wherever such taxes may arise on the **hammer price** and the **buyer's premium**. It is the buyer's responsibility to ascertain and pay all taxes due. In all circumstances Hong Kong law takes precedence. Christie's recommends you obtain your own independent tax advice.

For **lots** Christie's ships to the United States, a state sales or use tax may be due on the **hammer price**, **buyer's premium** and/or any other charges related to the **lot**, regardless of the nationality or citizenship of the purchaser. Christie's will collect sales tax where legally required. The applicable sales tax rate will be determined based upon the state, county, or locale to which the **lot** will be shipped. Successful bidders claiming an exemption from sales tax must provide appropriate documentation to Christie's prior to the release of the lot. For shipments to those states for which Christie's is not required to collect sales tax, a successful bidder may be required to remit use tax to that state's taxing authorities. Christie's recommends you obtain your own independent tax advice with further questions.

E WARRANTIES

1 SELLER'S WARRANTIES

For each **lot**, the seller gives a **warranty** that the seller:

(a) is the owner of the **lot** or a joint owner of the **lot** acting with the permission of the other co-owners or, if the seller is not the owner or a joint owner of the **lot**, has the permission of the owner to sell the **lot**, or the right to do so in law; and

(b) has the right to transfer ownership of the **lot** to the buyer without any restrictions or claims by anyone else. If either of the above **warranties** are incorrect, the seller shall not have to pay more than the **purchase price** (as defined in paragraph F1(a) below) paid by you to us. The seller will not be responsible to you for any reason for loss of profits or business, expected savings, loss of opportunity or interest, costs, damages, **other damages** or expenses. The seller gives no **warranty** in relation to any **lot** other than as set out above and, as far as the seller is allowed by law, all **warranties** from the seller to you, and all other obligations upon the seller which may be added to this agreement by law, are excluded.

2 OUR AUTHENTICITY WARRANTY

We warrant, subject to the terms below, that the **lots** in our sales are **authentic** (our "**authenticity warranty**"). If, within 5 years of the date of the auction, you give notice to us that your **lot** is not **authentic**, subject to the terms below, we will refund the **purchase price** paid by you. The meaning of **authentic** can be found in the glossary at the end of these Conditions of Sale. The terms of the **authenticity warranty** are as follows:

(a) It will be honoured for claims notified within a period of 5 years from the date of the auction. After such time, we will not be obligated to honour the **authenticity warranty**.

(b) It is given only for information shown in **UPPERCASE type** in the first line of the **catalogue description** (the "**Heading**"). It does not apply to any information other than in the **Heading** even if shown in **UPPERCASE type**.

(c) The **authenticity warranty** does not apply to any **Heading** or part of a **Heading** which is **qualified**. **Qualified** means limited by a clarification in a **lot's catalogue description** or by the use in a **Heading** of one of the terms listed in the section titled **Qualified Headings** on the page of the catalogue headed "Important Notices and Explanation of Cataloguing Practice". For example, use of the term "ATTRIBUTED TO..." in a **Heading** means that the **lot** is in Christie's opinion probably a work by the named artist but no **warranty** is provided that the **lot** is the work of the named artist. Please read the full list of **Qualified Headings** and a **lot's full catalogue description** before bidding.

(d) The **authenticity warranty** applies to the **Heading** as amended by any **Saleroom Notice**.

(e) The **authenticity warranty** does not apply where scholarship has developed since the auction leading to a change in generally accepted opinion. Further, it does not apply if the **Heading** either matched the generally accepted opinion of experts at the date of the sale or drew attention to any conflict of opinion.

(f) The **authenticity warranty** does not apply if the **lot** can only be shown not to be **authentic** by a scientific process which, on the date we published the catalogue, was not available or generally accepted for use, or which was unreasonably expensive or impractical, or which was likely to have damaged the **lot**.

(g) The benefit of the **authenticity warranty** is only available to the original buyer shown on the invoice for the **lot** issued at the time of the sale and only if, on the date of the notice of claim, the original buyer is the full owner of the **lot** and the **lot** is free from any claim, interest or restriction by anyone else. The benefit of this **authenticity warranty** may not be transferred to anyone else.

(h) In order to claim under the **authenticity warranty** you must:

(i) give us written notice of your claim within 5 years of the date of the auction. We may require full details and supporting evidence of any such claim;

(ii) at Christie's option, we may require you to provide the written opinions of two recognised experts in the field of the **lot** mutually agreed by you and us in advance confirming that the **lot** is not **authentic**. If we have any doubts, we reserve the right to obtain additional opinions at our expense; and

(iii) return the **lot** at your expense to the saleroom from which you bought it in the **condition** it was in at the time of sale.

(i) Your only right under this **authenticity warranty** is to cancel the sale and receive a refund of the **purchase price** paid by you to us. We will not, in any circumstances, be required to pay you more than the **purchase price** nor will we be liable for any loss of profits or business, loss of opportunity or value, expected savings or interest, costs, damages, **other damages** or expenses.

(j) **Books**. Where the **lot** is a book, we give an additional **warranty** for 14 days from the date of the sale that if on collation any **lot** is defective in text or illustration, we will refund your **purchase price**, subject to the following terms:

(a) This additional **warranty** does not apply to:

(i) the absence of blanks, half titles, tissue guards or advertisements, damage in respect of bindings, stains, spotting, marginal tears or other defects not affecting completeness of the text or illustration;

(ii) drawings, photographs, letters or manuscripts, signed photographs, music, atlases, maps or periodicals;

(iii) books not identified by title;

(iv) **lots** sold without a printed **estimate**;

(v) books which are described in the catalogue as sold not subject to return; or

(vi) defects stated in any **condition** report or announced at the time of sale.

(b) To make a claim under this paragraph you must give written details of the defect and return the **lot** to the sale room at which you bought it in the same **condition** as at the time of sale, within 14 days of the date of the sale.

(k) **South East Asian Modern and Contemporary Art and Chinese Calligraphy and Painting**.

In these categories, the **authenticity warranty** does not apply because current scholarship does not permit the making of definitive statements. Christie's does, however, agree to cancel a sale in either of these two categories of art where it has been proven the **lot** is a forgery. Christie's will refund to the original buyer the **purchase price** in accordance with the terms of Christie's **authenticity warranty**, provided that the original buyer notifies us with full supporting evidence documenting the forgery claim within twelve (12) months of the date of the auction. Such evidence must be satisfactory to us that the **lot** is a forgery in accordance with paragraph E2(h)(ii) above and the **lot** must be returned to us in accordance with E2h(iii) above. Paragraphs E2(b), (c), (d), (e), (f) and (g) and (i) also apply to a claim under these categories.

F PAYMENT

1 HOW TO PAY

(a) Immediately following the auction, you must pay the **purchase price** being:

(i) the **hammer price**; and

(ii) the **buyer's premium**; and

(iii) any duties, goods, sales, use, compensating or service tax.

Payment is due no later than by the end of the 7th calendar day following the date of the auction (the "**due date**").

(b) We will only accept payment from the registered bidder. Once issued, we cannot change the buyer's name on an invoice or re-issue the invoice in a different name. You must pay immediately even if you want to export the **lot** and you need an export licence.

(c) You must pay for **lots** bought at Christie's in Hong Kong in the currency stated on the invoice in one of the following ways:

(i) Christie's is pleased to offer clients the option of viewing invoices, paying and arranging shipping online through MyChristie's. To log in, or if you have yet to create an online account, please go to: www.christies.com/MyChristies. While this service is available for most lots, payment and shipping must be arranged offline for some items. Please contact Post-Sale Services directly to coordinate.

(ii) Wire transfer

You must make payments to:

HSBC

Head Office

1 Queen's Road, Central, Hong Kong

Bank code: 004

Account No. 062-305438-001

Account Name: Christie's Hong Kong Limited

SWIFT: HSBCHKHKKH

(iii) Credit Card.

We accept most major credit cards subject to certain conditions. We accept payments in person by credit card up to HK\$1,000,000 per auction sale although conditions and restrictions apply. China Union Pay is accepted with no limits on amounts. To make a 'cardholder not present' (CNP) payment, we accept payment up to HK\$1,000,000 per auction sale. CNP payments cannot be accepted by all salerooms and are subject to certain restrictions. Details of the conditions and restrictions applicable to credit card payments are available from our Post-Sale Services Department, whose details are set out in paragraph (d) below.

(iv) Cash

We accept cash subject to a maximum of HKD80,000 per buyer per year at our Post-Sale Services Department only (subject to conditions).

(v) Banker's draft

You must make these payable to Christie's Hong Kong Limited and there may be conditions.

(vi) Cheque

You must make cheques payable to Christie's Hong Kong Limited. Cheques must be from accounts in Hong Kong dollar from a Hong Kong bank.

(d) You must quote the sale number, your invoice number and client number when making a payment. All payments sent by post must be sent to: Christie's, Post-Sale Services Department, 22nd Floor Alexandra House, 18 Chater Road, Central, Hong Kong.

(e) For more information please contact our Post-Sale Services Department by phone on +852 2760 1766 or email to postsaleasia@christies.com.

2 TRANSFERRING OWNERSHIP TO YOU

You will not own the **lot** and ownership of the **lot** will not pass to you until we have received full and clear payment of the **purchase price**, even in circumstances where we have released the **lot** to the buyer.

3 TRANSFERRING RISK TO YOU

The risk in and responsibility for the **lot** will transfer to you from whichever is the earlier of the following:

(a) When you collect the **lot**; or

(b) At the end of the 30th day following the date of the auction or, if earlier, the date the **lot** is taken into care by a third party warehouse unless we have agreed otherwise with you in writing.

4 WHAT HAPPENS IF YOU DO NOT PAY

(a) If you fail to pay us the **purchase price** in full by the **due date**, we will be entitled to do one or more of the following (as well as enforce our rights under paragraph F5 and any other rights or remedies we have by law):

- (i) to charge interest from the **due date** at a rate of 7% a year above the 3-month HIBOR rate from time to time on the unpaid amount due;
- (ii) we can cancel the sale of the **lot**. If we do this, we may sell the **lot** again, publicly or privately on such terms we shall think necessary or appropriate, in which case you must pay us any shortfall between the **purchase price** and the proceeds from the resale. You must also pay all costs, expenses, losses, damages and legal fees we have to pay or may suffer and any shortfall in the seller's commission on the resale;
- (iii) we can pay the seller an amount up to the net proceeds payable in respect of the amount bid by your default in which case you acknowledge and understand that Christie's will have all of the rights of the seller to pursue you for such amounts;
- (iv) we can hold you legally responsible for the **purchase price** and may begin legal proceedings to recover it together with other losses, interest, legal fees and costs as far as we are allowed by law;
- (v) we can take what you owe us from any amounts which we or any company in the **Christie's Group** may owe you (including any deposit or other part-payment which you have paid to us);
- (vi) we can, at our option, reveal your identity and contact details to the seller;
- (vii) we can reject at any future auction any bids made by you or on your behalf or to obtain a deposit from you before accepting any bids;
- (viii) to exercise all the rights and remedies of a person holding security over any property in our possession owned by you, whether by way of pledge, security interest or in any other way as permitted by the law of the place where such property is located. You will be deemed to have granted such security to us and we may retain such property as collateral security for your obligations to us; and
- (ix) we can take any other action we see necessary or appropriate.

(b) If you owe money to us or to another **Christie's Group** company, we can use any amount you do pay, including any deposit or other part-payment you have made to us, or which we owe you, to pay off any amount you owe to us or another **Christie's Group** company for any transaction.

(c) If you make payment in full after the **due date**, and we choose to accept such payment we may charge you storage and transport costs from the date that is 31 calendar days following the auction in accordance with paragraphs Gd(i) and (ii). In such circumstances paragraph Gd(iv) shall apply.

5 KEEPING YOUR PROPERTY

If you owe money to us or to another **Christie's Group** company, as well as the rights set out in F4 above, we can use or deal with any of your property we hold or which is held by another **Christie's Group** company in any way we are allowed to by law. We will only release your property to you after you pay us or the relevant **Christie's Group** company in full for what you owe. However, if we choose, we can also sell your property in any way we think appropriate. We will use the proceeds of the sale against any amounts you owe us and we will pay any amount left from that sale to you. If there is a shortfall, you must pay us any difference between the amount we have received from the sale and the amount you owe us.

G COLLECTION AND STORAGE

(a) We ask that you collect purchased **lots** promptly following the auction (**but note that you may not collect any lot until you have made full and clear payment of all amounts due to us**).

(b) For information on collecting lots, Please contact Christie's Post-Sale Services Department on +852 2760 1766 / Email: postsaleasia@christies.com

(c) If you do not collect any **lot** promptly following the auction we can, at our option, remove the **lot** to another Christie's location or an affiliate or third party warehouse.

(d) If you do not collect a **lot** by the end of the 30th day following the date of the auction, unless otherwise agreed in writing:

- (i) we will charge you storage costs from that date.
- (ii) we can, at our option, move the **lot** to or within an affiliate or third party warehouse and charge you transport costs and administrative fees for doing so.
- (iii) we may sell the **lot** in any commercially reasonable way we think appropriate.
- (iv) the storage terms which can be found at www.christies.com/storage shall apply.
- (v) nothing in this paragraph is intended to limit our rights under paragraph F4.

H TRANSPORT AND SHIPPING

1 TRANSPORT AND SHIPPING

We will enclose a transport and shipping form with each invoice sent to you. You must make all transport and shipping arrangements. However, we can arrange to pack, transport and ship your property if you ask us to and pay the costs of doing so. We recommend that you ask us for an **estimate**, especially for any large items or items of high value that need professional packing before you bid. We may also suggest other handlers, packers, transporters or experts if you ask us to do so. For more information, please contact Christie's Post-Sale Services Department on +852 2760 1766 or email to postsaleasia@christies.com. We will take reasonable care when we are handling, packing, transporting and shipping a **lot**. However, if we recommend another company for any of these purposes, we are not responsible for their acts, failure to act or neglect.

2 EXPORT AND IMPORT

Any **lot** sold at auction may be affected by laws on exports from the country in which it is sold and the import restrictions of other countries. Many countries require a declaration of export for property leaving the country and/or an import declaration on entry of property into the country. Local laws may prevent you from importing a **lot** or may prevent you selling a **lot** in the country you import it into.

We will not be obliged to cancel your purchase and refund the **purchase price** if your **lot** may not be exported, imported or it is seized for any reason by a government authority. It is your responsibility to determine and satisfy the requirements of any applicable laws or regulations relating to the export or import of any **lot** you purchase.

(a) You alone are responsible for getting advice about and meeting the requirements of any laws or regulations which apply to exporting or importing any **lot** prior to bidding. If you are refused a licence or there is a delay in getting one, you must still pay us in full for the **lot**. We may be able to help you apply for the appropriate licences if you ask us to and pay our fee for doing so. However, we cannot guarantee that you will get one. For more information, please contact Christie's Post-Sale Services Department on +852 2760 1766 or email to postsaleasia@christies.com.

(b) You alone are responsible for any applicable taxes, tariffs or other government-imposed charges relating to the export or import of the **lot**. If Christie's exports or imports the **lot** on your behalf, and if Christie's pays

these applicable taxes, tariffs or other government-imposed charges, you agree to refund that amount to Christie's.

(c) Lots made of protected species

Lots made of or incorporating (irrespective of percentage) endangered and other protected species of wildlife are marked in the catalogue with the symbol (-) or (=):

The bag with the symbol (-) is subject to CITES export/import restrictions and the historical CITES paperwork is not available. These bags can only be shipped to addresses within Hong Kong SAR or collected from our Hong Kong saleroom. It will not be possible to obtain a CITES export permit to ship these bags to addresses outside Hong Kong SAR post-sale. Please contact the department for further information.

The bag with the symbol (=) is subject to CITES export/import restrictions and will require export / import permits to ship the bag outside Hong Kong SAR post sale. Buyers are responsible for obtaining and paying for the necessary permits. Please contact the department for further information.

This material includes, among other things, ivory, tortoiseshell, crocodile skin, rhinoceros horn, whalebone certain species of coral, and rosewood. You should check the relevant customs laws and regulations before bidding on any **lot** containing wildlife material if you plan to import the **lot** into another country. Several countries refuse to allow you to import property containing these materials, and some other countries require a licence from the relevant regulatory agencies in the countries of exportation as well as importation. In some cases, the **lot** can only be shipped with an independent scientific confirmation of species and/or age and you will need to obtain these at your own cost. If a **lot** contains elephant ivory, or any other wildlife material that could be confused with elephant ivory, (for example, mammoth ivory, walrus ivory, helmeted hornbill ivory) please see further important information in paragraph (c) if you are proposing to import the **lot** into the USA. We will not be obliged to cancel your purchase and refund the **purchase price** if your **lot** may not be exported, imported or it is seized for any reason by a government authority. It is your responsibility to determine and satisfy the requirements of any applicable laws or regulations relating to the export or import of property containing such protected or regulated material.

(d) US import ban on African elephant ivory

The USA prohibits the import of ivory from the African elephant. Any **lot** containing elephant ivory or other wildlife material that could be easily confused with elephant ivory (for example, mammoth ivory, walrus ivory, helmeted hornbill ivory) can only be imported into the US with results of a rigorous scientific test acceptable to Fish & Wildlife, which confirms that the material is not African elephant ivory. Where we have conducted such rigorous scientific testing on a **lot** prior to sale, we will make this clear in the lot description. In all other cases, we cannot confirm whether a **lot** contains African elephant ivory, and you will buy that **lot** at your own risk and be responsible for any scientific test or other reports required for import into the USA at your own cost. If such scientific test is inconclusive or confirms the material is from the African elephant, we will not be obliged to cancel your purchase and refund the **purchase price**.

(e) Lots of Iranian origin

Some countries prohibit or restrict the purchase and/or import of Iranian-origin "works of conventional craftsmanship" (works that are not by a recognized artist and/or that have a function, for example: carpets, bowls, ewers, tiles, ornamental boxes). For example, the USA prohibits the import of this type of property and its purchase by US persons (wherever located). Other countries, such as Canada, only permit the import of this property in certain circumstances. As a

convenience to buyers, Christie's indicates under the title of a **lot** if the **lot** originates from Iran (Persia). It is your responsibility to ensure you do not bid on or import a **lot** in contravention of the sanctions or trade embargoes that apply to you.

(f) **Gold**

Gold of less than 18ct does not qualify in all countries as 'gold' and may be refused import into those countries as 'gold'.

(g) **Watches**

Many of the watches offered for sale in this catalogue are pictured with straps made of endangered or protected animal materials such as alligator or crocodile. These **lots** are marked with the symbol **Ψ** in the catalogue. These endangered species straps are shown for display purposes only and are not for sale. Christie's will remove and retain the strap prior to shipment from the sale site. At some sale sites, Christie's may, at its discretion, make the displayed endangered species strap available to the buyer of the **lot** free of charge if collected in person from the sale site within 1 year of the date of the sale. Please check with the department for details on a particular **lot**.

For all symbols and other markings referred to in paragraph H2, please note that **lots** are marked as a convenience to you, but we do not accept liability for errors or for failing to mark **lots**.

I OUR LIABILITY TO YOU

(a) We give no **warranty** in relation to any statement made, or information given, by us or our representatives or employees, about any **lot** other than as set out in the **authenticity warranty** and, as far as we are allowed by law, all **warranties** and other terms which may be added to this agreement by law are excluded. The seller's **warranties** contained in paragraph E1 are their own and we do not have any liability to you in relation to those **warranties**.

(b)(i) We are not responsible to you for any reason (whether for breaking this agreement or any other matter relating to your purchase of, or bid for, any **lot**) other than in the event of fraud or fraudulent misrepresentation by us or other than as expressly set out in these conditions of sale; and

(ii) We do not give any representation, warranty or guarantee or assume any liability of any kind in respect of any **lot** with regard to merchantability, fitness for a particular purpose, description, size, quality, condition, attribution, authenticity, rarity, importance, medium, provenance, exhibition history, literature, or historical relevance. Except as required by local law, any warranty of any kind is excluded by this paragraph.

(c) In particular, please be aware that our written and telephone bidding services, Christie's LIVE™, **condition** reports, currency converter and saleroom video screens are free services and we are not responsible to you for any error (human or otherwise), omission, breakdown, or delay, unavailability, suspension or termination of any of these services.

(d) We have no **responsibility** to any person other than a buyer in connection with the purchase of any **lot**.

(e) If, in spite of the terms in paragraphs (a) to (d) or E2(i) above, we are found to be liable to you for any reason, we shall not have to pay more than the **purchase price** paid by you to us. We will not be responsible to you for any reason for loss of profits or business, loss of opportunity or value, expected savings or interest, costs, damages, or expenses.

J OTHER TERMS

1 OUR ABILITY TO CANCEL

In addition to the other rights of cancellation contained in this agreement, we can cancel a sale of a **lot** if we reasonably believe that completing the transaction is, or may be, unlawful or that the sale places us or the seller

under any liability to anyone else or may damage our reputation.

2 RECORDINGS

We may videotape and record proceedings at any auction. We will keep any personal information confidential, except to the extent disclosure is required by law. However, we may, through this process, use or share these recordings with another **Christie's Group** company and marketing partners to analyse our customers and to help us to tailor our services for buyers. If you do not want to be videotaped, you may make arrangements to make a telephone or written bid or bid on Christie's LIVE™ instead. Unless we agree otherwise in writing, you may not videotape or record proceedings at any auction.

3 COPYRIGHT

We own the copyright in all images, illustrations and written material produced by or for us relating to a **lot** (including the contents of our catalogues unless otherwise noted in the catalogue). You cannot use them without our prior written permission. We do not offer any guarantee that you will gain any copyright or other reproduction rights to the **lot**.

4 ENFORCING THIS AGREEMENT

If a court finds that any part of this agreement is not valid or is illegal or impossible to enforce, that part of the agreement will be treated as being deleted and the rest of this agreement will not be affected.

5 TRANSFERRING YOUR RIGHTS AND RESPONSIBILITIES

You may not grant a security over or transfer your rights or responsibilities under these terms on the contract of sale with the buyer unless we have given our written permission. This agreement will be binding on your successors or estate and anyone who takes over your rights and responsibilities.

6 TRANSLATIONS

If we have provided a translation of this agreement, we will use the English version in deciding any issues or disputes which arise under this agreement.

7 PERSONAL INFORMATION

We will hold and process your personal information and may pass it to another **Christie's Group** company for use as described in, and in line with, our privacy policy at www.christies.com.

8 WAIVER

No failure or delay to exercise any right or remedy provided under these Conditions of Sale shall constitute a waiver of that or any other right or remedy, nor shall it prevent or restrict the further exercise of that or any other right or remedy. No single or partial exercise of such right or remedy shall prevent or restrict the further exercise of that or any other right or remedy.

9 LAW AND DISPUTES

The rights and obligations of the parties with respect to these Conditions of Sale, the conduct of the auction and any matters connected with any of the foregoing shall be governed and interpreted by the Hong Kong laws. By bidding at auction, whether present in person or by agent, by written bid, telephone or other means, the buyer shall be deemed to have accepted these Conditions and submitted, for the benefit of Christie's, to the exclusive jurisdiction of the Hong Kong courts, and also accepted that Christie's also has the right to pursue remedies in any other jurisdiction in order to recover any outstanding sums due from the buyer.

10 REPORTING ON WWW.CHRISTIES.COM

Details of all **lots** sold by us, including **catalogue descriptions** and prices, may be reported on www.christies.com. Sales totals are **hammer price** plus **buyer's premium** and do not reflect costs, financing fees, or application of buyer's or seller's credits. We regret that we cannot agree to requests to remove these details from www.christies.com.

K GLOSSARY

auctioneer : the individual auctioneer and/or Christie's.
authentic : a genuine example, rather than a copy or forgery of:

(i) the work of a particular artist, author or manufacturer, if the **lot** is described in the **Heading** as the work of that artist, author or manufacturer;

(ii) a work created within a particular period or culture, if the **lot** is described in the **Heading** as a work created during that period or culture;

(iii) a work for a particular origin source if the **lot** is described in the **Heading** as being of that origin or source; or

(iv) in the case of gems, a work which is made of a particular material, if the **lot** is described in the **Heading** as being made of that material.

authenticity warranty : the guarantee we give in this agreement that a **lot** is **authentic** as set out in section E2 of this agreement.

buyer's premium : the charge the buyer pays us along with the **hammer price**.

catalogue description : the description of a **lot** in the catalogue for the auction, as amended by any saleroom notice.

Christie's Group : Christie's International Plc, its subsidiaries and other companies within its corporate group.

condition : the physical **condition** of a **lot**.

due date : has the meaning given to it paragraph F1(a).

estimate : the price range included in the catalogue or any saleroom notice within which we believe a **lot** may sell. **Low estimate** means the lower figure in the range and **high estimate** means the higher figure. The **mid estimate** is the midpoint between the two.

hammer price : the amount of the highest bid the **auctioneer** accepts for the sale of a **lot**.

Heading : has the meaning given to it in paragraph E2.

lot : an item to be offered at auction (or two or more items to be offered at auction as a group).

other damages : any special, consequential, incidental or indirect damages of any kind or any damages which fall within the meaning of 'special', 'incidental' or 'consequential' under local law.

purchase price : has the meaning given to it in paragraph F1(a).

provenance : the ownership history of a **lot**.

qualified : has the meaning given to it in paragraph E2 and **Qualified Headings** means the section headed **Qualified Headings** on the page of the catalogue headed 'Important Notices and Explanation of Cataloguing Practice'.

reserve : the confidential amount below which we will not sell a **lot**.

saleroom notice : a written notice posted next to the **lot** in the saleroom and on www.christies.com, which is also read to prospective telephone bidders and notified to clients who have left commission bids, or an announcement made by the **auctioneer** either at the beginning of the sale, or before a particular **lot** is auctioned.

UPPER CASE type : means having all capital letters.

warranty : a statement or representation in which the person making it guarantees that the facts set out in it are correct.

業務規定 · 買方須知

業務規定

業務規定和重要通知及目錄編列方法之說明列明佳士得拍賣刊載在本目錄中**拍賣品**的條款。通過登記競投和/或在拍賣會中競投即表示您同意接受這些條款，因此，您須在競投之前仔細閱讀這些條款。下述粗體字體詞語的解釋在尾部詞匯表列明。

除非佳士得擁有**拍賣品**所有權（以△標示），佳士得為賣方的代理人。

A. 拍賣之前

1. 拍賣品描述

- 目錄描述部分使用的某些詞匯有特殊意義。詳情請見構成條款部分的重要通知及目錄編列方法之說明。對目錄內的標識的解釋，請見本目錄內“本目錄中使用的各類標識”。
- 本公司在本目錄中對任何**拍賣品**的描述，**拍賣品狀況**報告及其它陳述（不管是口頭還是書面），包括**拍賣品**性質或**狀況**、藝術家、時期、材料、規格尺寸或來源均屬我們意見之表述，而不應被作為事實之陳述。我們不像專業的歷史學家及學者那樣進行深入的研究。所有的尺寸及重量僅為粗略估計。

2. 對於**拍賣品**描述佳士得所負的責任

我們不對**拍賣品**的性質提供任何保證，除了下述第 E2 段的**真品保證**以及第 1 段另有約定。

3. 狀況

- 在我們拍賣會上拍賣的**拍賣品**狀況可因年代、先前損壞、修復、修理及損耗等因素而差異甚大。其性質即意味著幾乎不可能處於完美的**狀況**。**拍賣品**是按照其在拍賣之時的情況以“現狀”出售，而且不包括佳士得或賣方的任何陳述或保證或對於**狀況**的任何形式的責任承擔。
- 在本目錄條目或**狀況**報告中提及**狀況**不同於對**狀況**的完整描述，圖片可能不會清晰展示**拍賣品**。**拍賣品**的色彩和明暗度在印刷品或屏幕上看起來可能會與實體檢查時的情況不同。**狀況**報告可協助您評估**拍賣品**的**狀況**。為方便買方，**狀況**報告為免費提供，僅作為指引。**狀況**報告提供了我們的意見，但是可能未指出所有的缺陷、內在瑕疵、修復、更改及改造，因為我們的僱員不是專業修復或維護人員。出於這個原因，我們不能替您親自檢查**拍賣品**或您自己尋求的專業意見。買方有責任確保自己已經要求提供、收悉及考慮了任何**狀況**報告。

4. 拍賣之前檢查**拍賣品**

- 如果您計劃競投一件**拍賣品**，應親自或通過具有專業知識之代表檢視，以確保您接受**拍賣品**描述及**狀況**。我們建議您從專業修復人員或其它專業顧問那裏索取意見。
- 拍賣之前的檢視免費向公眾開放。在拍賣之前的檢視或通過預約，我們的專家可在場內答問題。

5. 估價

估價是基於**拍賣品**的**狀況**、稀有程度、質量、來源及類似物品的近期拍賣決定。**估價**可能會改變。您或任何其他人在任何情況下都不可能依賴**估價**，將其作為**拍賣品**的實際售價的預測或保證。**估價**不包括**買方酬金**或任何適用的稅費。**估價**可能以拍賣場當地貨幣以外的貨幣顯示並僅作指引。本目錄使用的貨幣兌換率是根據最近目錄打印時的兌換率設定，所以可能與拍賣當日兌換率有差別。

6. 撤回

佳士得有權單方面決定在**拍賣品**拍賣過程中或拍賣之前的任何時間將**拍賣品**撤回。佳士得無須就任何撤回決定向您承擔責任。

7. 珠寶

- 有色寶石（如紅寶石、藍寶石及綠寶石）可能經過處理以改良外觀，包括加熱及上油等方法。這些方法都被國際珠寶行業認可，但是經處理的寶石的硬度可能會降低及/或在日後需要特殊的保養。
- 所有類型的寶石均可能經過某些改良處理。如果某件**拍賣品**沒有報告，您可以在拍賣日之前至少提前三周向我們要求寶石鑑定報告，報告的費用由您支付。
- 我們不會為每件拍賣的寶石拿取鑑定報告。若我們有從國際認可的寶石鑑定實驗室取得鑑定報告，我們會在本目錄中提及。從美國寶石鑑定實驗室發出的鑑定報告會描述對寶石的改良或處理。歐洲寶石鑑定實驗室的報告僅在我們要求的時候，才會提及對寶石的改良及處理，但

是該報告會確認該寶石沒有被改良或處理。因各實驗室使用方法和技術的差異，對某寶石是否處理過、處理的程度或處理是否為永久性，都可能持不同意見。寶石鑑定實驗室僅對報告作出日之前實驗室所知悉的改進及處理進行報告。

- 對於珠寶銷售來說，**估價**是以寶石鑑定報告中的信息為基礎，如果沒有報告，就會認為寶石可能已經被處理或提升過。

8. 鐘錶

- 幾乎所有的鐘錶在使用期內都被修理過，可能都含有非原裝零部件。我們不能保證任何鐘錶的任何個別零部件都是原裝。被陳述為“關聯”字樣的錶帶不是原裝錶帶，可能不是**真品**。拍賣的鐘可能跟隨沒有鐘擺、鐘錘或鑰匙出售。
- 收藏家等級的鐘錶經常有非常精細複雜的機械構造，可能需要一般保養服務、更換電池或進一步的修理工作，而這些都由買方負責。我們不保證每一隻鐘錶都是在良好運作狀態。除非目錄中有提及，我們不提供證書。
- 大多數的錶都被打開過查看機芯的型號及質量。因為這個原因，帶有防水錶殼的錶可能不能防水，在使用之前我們建議您讓專業鐘錶師先檢驗。手錶及錶帶的拍賣及運送方面的重要信息，請見第 H2(f) 段。

B. 登記競投

1. 新競投人

- 如果這是您第一次在佳士得競投，或者您曾參與我們的拍賣，但在過去兩年內未曾從任何佳士得拍賣場成功競投過任何東西，您必須在拍賣之前至少 48 個小時登記，以給我們足夠的時間來處理及批准您的登記。我們有權單方面不允許您登記成為競投人。您需提供以下資料：
 - 個人客戶：帶有照片的身份證明（護照執照、國民身份證或護照）及（如果身份證文件上沒有顯示現時住址資料）現時住址證明，如：用事業帳單或銀行月結單。
 - 公司客戶：顯示名稱及註冊地址的公司註冊證明或類似文件，公司地址證明，被授權競投者附有照片的身份證文件，由法定代表人簽署及蓋有公司章（若有）的競投授權書，以及列出所有董事和受益股東的文件證明。
 - 信托、合夥、離岸公司及其它業務結構，請提前聯繫我們商談要求。
- 我們可能要求您向我們提供財務證明及/或押金作為許可您競投的條件。如需幫助，請聯繫我們的客戶服務部：+852 2760 1766。

2. 再次參與競投的客人

我們可選擇要求您提供以上 B1(a) 段所提及的現時身份證明、財務證明及/或押金作為許可您競投的條件。如果您過去兩年內沒有從我們的拍賣會成功投得**拍賣品**，或者您上次擬出價金額高於過往，請聯繫我們的投標部：+852 2978 9910 或電郵至 bidsasia@christies.com。

3. 如果您未能提供正確的文件

如果我們認為，您未能滿足我們對競投者身份及登記手續的要求，包括但不限於完成及滿足本公司可能要求進行的所有反洗黑錢和/或反恐怖主義財政審查，我們可能會不允許您登記競投，而如果您成功投得**拍賣品**，我們可能撤銷您與賣方之間的買賣合約。佳士得有權單方面決定所須的身份證明文件類別，作為滿足我們對競投者身份及登記手續的要求。

4. 代表他人競投

- 作為授權競投人**：如果您代表他人競投，在競投前，委託人需要完成以上的登記手續及提供已簽署的授權書，授權您代表其競投。
 - 作為隱名委托人的代理人**：如果您以代理人身份為隱名委托人（最終的買方）進行競投，您同意承擔支付**購買款項**和所有其他應付款項的個人責任。並且，您保證：
 - 您已經根據所有適用的反洗黑錢及制裁法律對**拍賣品**的最終的買方進行必要的客戶盡職調查，同意我們依賴該盡職調查。並且，您將在不少於 5 年的期間裏保存證明盡職調查的文件和記錄。
 - 您在收到我們書面要求後可以將證明盡職調查的文件和記錄立即提供給獨立第三方審計人員即時查閱。我們不會向任何第三方披露上述文件和記錄，除非 (1) 它們已經在公共領域存在，(2) 根據法律要求須被披露，(3) 符合反洗黑錢法律規定。
 - 您和最終的買方之間的安排不是為了便於任何涉稅犯罪。
 - 您不知曉並且沒有理由懷疑用於結算的資金和任何犯罪收入有關或最終的買方因洗黑錢、恐怖活動或其他基於洗黑錢的犯罪而被調查，被起訴或被定罪。
- 除非競投人和佳士得在拍賣開始前書面同意競投人僅作為佳

士得認可並指定的第三方的代理參與競投並且佳士得只會向該指定第三方收取付款，競投人同意就繳付**購買款項**和所有其他應付款項負上個人法律責任。

5. 親自出席競投

如果您希望在拍賣現場競投，必須在拍賣舉行前至少 30 分鐘辦理登記手續，並索取競投號碼牌。如需協助，請聯繫客戶服務部：+852 2760 1766。

6. 競投服務

下述的競投服務是為方便客戶而設，如果在提供該服務出現任何錯誤（人為或其它），遺漏或故障，佳士得均不負上任何責任。

(A) 電話競投

您必須在拍賣開始前至少 24 小時辦理申請電話競投。佳士得只會在接受安排人員協助電話競投的情況下接受電話競投。估價低於 30,000 元之**拍賣品**將不接受電話競投。若需要以英語外的其他語言進行競投，須儘早在拍賣之前預先安排。電話競投可被錄音。以電話競投即代表您同意其對話被錄音。您同意電話競投受業務規定管限。

(B) 在 Christie's LIVE™ 網絡競投

在某些拍賣會，我們會接受網絡競投。請登入 www.christies.com/livebidding，點擊“現場競投”圖標，瞭解如何從電腦聆聽及觀看拍賣及參與競投。網絡競投受業務規定及 Christie's LIVE™ 使用條款的管限，詳情請見 www.christies.com 網站。

(C) 書面競投

您可於本目錄，任何佳士得辦公室或通過 www.christies.com 選擇拍賣並查看**拍賣品**取得書面競投表格。您必須在拍賣開始前至少 24 小時提交已經填妥的書面競投表格。投標必須是以拍賣會當地的貨幣為單位。拍賣官將在參考**底價**後，合理地履行書面競投務求以可能的最低價行使書面標。如果您以書面競投一件沒有**底價**的**拍賣品**，而且沒有其他更高叫價，我們會為您以**低價估價**的 50% 進行競投；如果您的書面標比上述更低，則以您的書面標的價格進行競投。如佳士得收到多個競投價相等的書面競投，而在拍賣時此等競投價乃該**拍賣品**之最高價，則該**拍賣品**售給最先送達其書面競投書給本公司之競投人。

C. 舉行拍賣

1. 進入拍賣現場

我們有權不允許任何人士進入拍賣場地，參與拍賣，亦可拒絕接受任何競投。

2. 底價

除非另外列明，所有**拍賣品**均有**底價**。不定有**底價**的**拍賣品**，在**拍賣品**號碼旁選用“標記”。**底價**不會高於**拍賣品**的**低價估價**。

3. 拍賣官之酌情權

- 拍賣官**可以酌情選擇：
- 拒絕接受任何競投；
 - 以其決定方式將競投提前或拖後，或改變**拍賣品**的順序；
 - 撤回任何**拍賣品**；
 - 將任何**拍賣品**分開拍賣或將兩件或多件**拍賣品**合併拍賣；
 - 重開或繼續競投，即便已經下槌；
 - 如果有關於競投的錯誤或者爭議，無論是在拍賣時或拍賣後，選擇繼續拍賣、決定誰是成功競投人、取消**拍賣品**的拍賣，或是將**拍賣品**重新拍賣或出售。如果您相信**拍賣官**在接受成功投標時存在錯誤，您必須在拍賣日後 3 個工作天內提供一份詳細記述您訴求的書面通知。**拍賣官**將本着真誠考慮該訴求。如果**拍賣官**在根據本段行使酌情權，在拍賣完成後決定取消出售一件**拍賣品**，或是將**拍賣品**重新拍賣或出售，**拍賣官**最遲將在拍賣日後第 7 個日曆日結束前通知成功競投人。拍賣官有最終決定權。本段不在任何情況下影響佳士得依據本業務規定中任何其他適用規定，包括第 B(3)、E(2)(i)、F(4)、及 J(i) 段中所列的取消權，取消出售一件**拍賣品**的權利。

4. 競投

- 拍賣官**接受以下競投：
- 拍賣會場參與競投的競投人；
 - 從電話競投人，通過 Christie's LIVE™（如第 B6 部分所示）透過網絡競投的競投人；
 - 拍賣之前提交佳士得的書面競投（也稱為不在場競投或委託競投）。

5. 代表賣方競投

拍賣官可選擇代表賣方的方式連續競投或以回應其他競投者的投標而競投的方式，直至達到**底價**以下。**拍賣官**不會特

別指明此乃代表賣方的競投。拍賣官不會代表賣方作出相等或高於低價之出價。就不設低價的拍賣品，拍賣官通常會以低價估價的 50% 開始拍賣。如果在此價位沒有人競投，拍賣官可以自行斟酌將價格下降繼續拍賣，直至有人競投，然後從該價位向上拍賣。如果無人競投該拍賣品，拍賣官可視該拍賣品為流拍拍賣品。

6. 競投價遞增幅度

競投通常從低於低價估計開始，然後逐步增加（競投價遞增幅度）。拍賣官會自行決定競投開始價位及遞增幅度。本目錄內的書面競投表格上顯示的是一般遞增幅度，僅供閣下參考。

7. 貨幣兌換

拍賣會的顯示板，Christie's LIVE™ 和佳士得網站可能會以拍賣場地貨幣外的主要貨幣來展示競投。任何佳士得使用的兌換率僅作指引，佳士得並不受其約束。對於在提供該服務出現的任何錯誤（人為或其它），遺漏或故障，佳士得並不負責。

8. 成功競投

除非拍賣官決定使用以上 C3 段中的酌情權，拍賣官下標即表示對最終競投價之接受。這代表賣方和成功競投人之間的買賣合約之訂立。我們僅向已登記的成功競投人開具發票。拍賣後我們會以郵寄及/或電子郵件方式發送發票，但我們並不負責通知閣下競投是否成功。如果您以書面競投，拍賣後您應盡快以電話聯繫我們或親臨本公司查詢競投結果，以避免產生不必要的倉儲費用。

9. 競投地法律

當您在我們的拍賣中競投時，您同意您會嚴格遵守所有在拍賣時生效並適用於相關拍賣場所的當地法律及法規。

D. 買方酬金及稅款

1. 買方酬金

成功競投人除支付成交價外，亦同意支付本公司以該拍賣品成交價計算的買方酬金。酬金費率按每件拍賣品成交價首港幣 2,500,000 元之 25%；加逾港幣 2,500,000 元以上至港幣 30,000,000 元部分之 20%；加逾港幣 30,000,000 元以上之 13.5% 計算。

2. 稅費

成功競投者將負責所有適用拍賣品稅費，包括增值稅，銷售或補償使用稅費或者所有基於成交價和買方酬金而產生的該等稅費。買方有責任查明並支付所有應付稅費。在任何情況下香港法律先適用。佳士得建議您徵詢獨立稅務意見。有關佳士得運送至美國的拍賣品，不論買方國籍或公民身份，均可能須支付基於成交價、買方酬金和/或與拍賣品有關的其他費用而產生的州銷售稅或使用稅費。佳士得將根據法律要求收取銷售稅。適用銷售稅率由拍賣品將運送到的州分、縣、地點而決定。要求豁免銷售稅的成功競投人必須在提取拍賣品之前向佳士得提供適當文件。佳士得不須收取稅費的州分，成功競投人可能須繳付稅費予該州之稅務機構。佳士得建議您徵詢獨立稅務意見。

E. 保證

1. 賣方保證

對於每件拍賣品，賣方保證其：

- 為拍賣品的所有人，或拍賣品的共有人之一並獲得其他共有人的許可；或者，如果賣方不是拍賣品的所有人或共有人之一，其已獲得所有人的授權出售拍賣品或其任法律上有權這麼做；
- 有權利將拍賣品的所有權轉讓給買方，且該權利不負擔任何限制或任何其他人之索賠權。

如果以上任何保證不確實，賣方不必支付超過您已向我們支付的購買款項（詳見以下第 F1(a) 段定義）的金額。賣方不會就閣下利潤上或經營的損失、預期存款、商機喪失或利息的損失、成本、賠償金、其他賠償或支出承擔責任。賣方不就任何拍賣品提供任何以上列舉之外的保證；只要法律許可，所有賣方對您做出的保證及法律要求加入本協議的所有其它賣方責任均被免除。

2. 真品保證

在不抵觸以下條款的情況下，本公司保證我們拍賣的拍賣品都是真品（我們的“真品保證”）。如果在拍賣日後的五年內，您通知我們您的拍賣品不是真品，在符合以下條款規定之下，我們將把您支付的購買款項退還給您。業務規定的詞匯表裏有對“真品”一詞做出解釋。真品保證條款如下：

- 我們對在拍賣日後 5 年內提供的申索通知提供真品保證。此期限過後，我們不再提供真品保證。
- 我們只會對本目錄描述第一行（“標題”）以大階字體注明的資料作出真品保證。除了標題中顯示的資料，我們不對任何標題以外的資料（包括標題以外的大階字體註明）作出任何保證。
- 真品保證不適用於有保留標題或有保留的部分標題。有保留是指受限於拍賣品目錄描述內的解釋，或者標題中有

“重要通告及目錄編列方法之說明”內有保留標題的某些字眼。例如：標題中對“認為是...之作品”的使用指佳士得認為拍賣品可能是某位藝術家的作品，但是佳士得不保證該作品一定是該藝術家的作品。在競投前，請閱畢“有保留標題”列表及拍賣品的目錄描述。

(d) 真品保證適用於被拍賣會通告修訂後的標題。

(e) 真品保證不適用於在拍賣之後，學術發展導致被普遍接受的學者或專家意見有所改變。此保證亦不適用於在拍賣日時，標題乎被普遍接受的學者或專家的意見，或標題指出意見衝突的地方。

(f) 如果拍賣品只有通過科學鑒定方法才能鑒定出不是真品，而在我們出版目錄之日，該科學方法還未存在或未被普遍接納，或價格太昂貴或不實際，或者可能損壞拍賣品，則真品保證不適用。

(g) 真品保證僅適用於拍賣品在拍賣時由佳士得發出之發票之原本買方，且僅在申索通知做出之日原本買方是拍賣品的唯一所有人，且拍賣品不受其他申索權、權利主張或任何其他制約的限制。此真品保證中的利益不可以轉讓。

(h) 要申索真品保證下的權利，您必須：

(i) 在拍賣日後 5 年內，向我們提供書面的申索通知。我們可以要求您提供上述申索完整的細節及佐證證據；

(ii) 佳士得有權要求您提供為佳士得及您均事先同意的在此拍賣品領域被認可的兩位專家的書面意見，確認該拍賣品不是真品。如果我們有任何疑問，我們保留自己支付費用獲取更多意見的權利；及

(iii) 自費交回與拍賣時狀況相同的拍賣品給佳士得拍賣場。

(i) 您在真品保證下唯一的權利就是取消該項拍賣及取回已付的購買款項。在任何情況下我們不須支付超過您已向我們支付的購買款項的金額，同時我們也無須對任何利潤或經營損失、商機或價值喪失、預期存款或利息、成本、賠償金或其他賠償作出承擔責任。

(j) 書籍。如果拍賣品為書籍，我們提供額外自拍賣日起為期 14 天的保證，如經校對後，拍賣品的文本或圖標存有瑕疵，在以下條款的規限下，我們將退回已付的購買款項：

- 此類外保證不適用於：
 - 缺少空白頁、扉頁、保護頁、廣告、及書籍鑲邊的破損、污漬、邊緣磨損或其它不影響文本及圖標完整性的瑕疵；
 - 繪圖、簽名、書信或手稿；帶有簽名的照片、音樂唱片、地圖冊、地圖或期刊；
 - 沒有標題的書籍；
 - 沒有標明估價的已售出拍賣品；
 - 目錄中表明售出後不可退貨的書籍；
 - 狀況報告中或拍賣時公告的瑕疵；
- 要根據本條規定申索權利，您必須在拍賣後的 14 天內就有關瑕疵提交書面通知，並交回與拍賣時狀況相同的拍賣品給當時進行拍賣的佳士得拍賣場。

(k) 東南亞現代及當代藝術以及中國書畫。

真品保證並不適用於此類別拍賣品。目前學術界不容許對此類別作出確實之說明，但佳士得同意取消被證實為贗品之東南亞現代及當代藝術以及中國書畫拍賣品之交易。已付之購買款項則根據佳士得真品保證的條款退還予原本買方，但買方必須在拍賣日起 12 個月內以書面通知本公司有關拍賣品為贗品並能按以上 E2(h)(ii) 的規定提供令佳士得滿意的證據，證實該拍賣品為贗品，及須按照以上 E2(h)(iii) 規定交回拍賣品給我們。E2(b), (c), (d), (e), (f), (g) 和 (i) 適用於此類別之申索。

F. 付款

1. 付款方式

(a) 拍賣後，您必須立即支付以下購買款項：

- 成交價；和
 - 買方酬金；和
 - 任何關稅、有關貨物、銷售、使用、補償或服務稅項；
- 所有款項須於拍賣後 7 個日曆天內悉數付清（“到期付款日”）。

(b) 我們只接受登記競投人付款。發票一旦開具，發票上買方的姓名不能更換，我們亦不能以不同姓名重新開具發票。即使您欲將拍賣品出口且需要出口許可證，您也必須立即支付以上款項。

(c) 在香港佳士得購買的拍賣品，您必須按照發票上顯示的貨幣以以下方式支付：

- 佳士得通過“MyChristie's”網上賬戶為客人提供查看發票、付款及運送服務。您可直接登錄查詢（如您還未註冊線上賬戶，請登錄 www.christies.com/MyChristies 進行註冊）。本服務適用於大多數拍賣品，但仍有少數拍賣品的付款和運送安排不能通過網上進行。如需協助，請與售後服務部聯絡。
- 電匯至：
香港上海匯豐銀行總行
香港中環皇后大道中 1 號
銀行編號：004
賬號：062-305438-001
賬名：Christie's Hong Kong Limited
收款銀行代號：HSBCHKHKHK

(iii) 信用卡

在符合我們的規定下，我們接受各種主要信用卡付款。本公司每次拍賣接受總數不超過港幣 1,000,000 元之現場信用卡付款，但有關條款及限制適用。以中國銀聯支付方式沒有金額限制。如要以“持卡人不在場”（CNP）的方式支付，本公司每次拍賣接受總數不超過港幣 1,000,000 元之付款。CNP 付款不適用於所有佳士得拍賣場，並受某些限制。適用於信用卡付款的條款和限制可從佳士得售後服務部獲取，詳情列於以下 (d) 段：

(iv) 現金

本公司每年只接受每位買方總數不超過港幣 80,000 元之現金付款（須受有關條件約束）；

(v) 銀行匯票

抬頭請註明“佳士得香港有限公司”（須受有關條件約束）；

(vi) 支票

抬頭請註明“佳士得香港有限公司”。支票必須於香港銀行承兌並以港幣支付。

(d) 支付時請註明拍賣號碼、發票號碼及客戶號碼；以郵寄方式支付必須發送到：佳士得香港有限公司，售後服務部（地址：香港中環遮打道 18 號歷山大廈 22 樓）。

(e) 如要瞭解更多信息，請聯繫售後服務部。電話 +852 2760 1766 或發電郵至 postsaleasia@christies.com

2. 所有權轉移

只有我們自您處收到全額且清算購買款項後，您才擁有拍賣品及拍賣品的所有權，即使本公司已將拍賣品交給您。

3. 風險轉移

拍賣品的風險和責任自以下日期起將轉移給您（以較早者為準）：

- 買方提貨日；
- 自拍賣日起 30 日後，如較早，則拍賣品由第三方倉庫保管之日起；除非另行協議。

4. 不付款之補救辦法

(a) 如果到期付款日，您未能全數支付購買款項，我們將有權行使以下一項或多項（及執行我們在 F5 段的權利及法律賦予我們的其它權利或補救辦法）：

- 自到期付款日起，按照尚欠款項，收取高於香港金融管理局不時公布的三個月銀行同業拆息加 7% 的利息；
- 取消交易並按照我們認為合適的條件對拍賣品公開重新拍賣或私下重新售賣。您必須向我們支付原來您應支付的購買款項與再次轉賣收益之間的差額。您也必須支付我們必須支付或可能蒙受的一切成本、費用、損失、賠償、法律費用及任何賣方酬金的差額；
- 代不履行責任的買方支付賣方應付的拍賣淨價金額。您承認佳士得有賣方之所有權利向您提出追討；
- 您必須承擔尚欠之購買款項，我們可就收回此金額而向您提出法律訴訟程序及在法律許可下向您索回之其他損失、利息、法律費用及其他費用；
- 將我們或佳士得集團任何公司欠您之款項（包括您已付給我們之任何保證金或部分付款）用以抵銷您未付之款項；

(vi) 我們可以選擇將您的身份及聯繫方式披露給買方；

(vii) 在將來任何拍賣中，不允許您或您的代表作出競投，或在接受您競投之前向您收取保證金；

(viii) 在拍賣品所處地方之法律許可之下，佳士得就您擁有並由佳士得管有的拍賣品作為抵押品以及抵押品持有人身份行使最高程度之權利及補救方法，不論是典當方式、抵押方式或任何其他形式。您則被視為已授與本公司該等抵押及本公司可保留或售賣此物品作為買方對本公司及賣方的附屬抵押責任；

(ix) 採取我們認為必要或適當的任何行動。

(b) 將您已付的款項，包括保證金及其他部份付款或我們欠下您之款項用以抵銷您欠我們或其他佳士得集團公司的款項。

(c) 如果您在到期付款日之後支付全部款項，同時，我們選擇接受該款項，我們可以自拍賣後第 31 日起根據 G(d)(i) 及 (ii) 段向您收取倉儲和運輸費用。在此情況下，G(d)(iv) 段將適用。

5. 扣押拍賣品

如果您欠我們或其他佳士得集團公司款項，除了以上 F4 段的權利，在法律許可下，我們可以以任何方式使用或處置您存於我們或其它佳士得集團公司的拍賣品。只有在您全額支付欠下我們或相關佳士得集團公司的全部款項後，您方可領取有關拍賣品。我們亦可選擇將您的拍賣品按照我們認為適當的方式出售。我們將用出售拍賣品的銷售所得來抵銷您欠下我們的任何款項，並支付您任何剩餘部分。如果銷售所得不足以抵扣，您須支付差額。

G. 提取及倉儲

(a) 我們要求您在拍賣之後立即提取您購買的拍賣品（但請注意，在全數付清所有款項之前，您不可以提取拍賣品）。

- (b) 有關提取拍賣品之詳情，請聯繫售後服務部。電話 +852 2760 1766 或發電郵至: postsaleasia@christies.com
- (c) 如果您未在拍賣完畢立即提取您購買的**拍賣品**，我們有權將拍賣品移送到其他佳士得所在處或其關聯公司或第三方倉庫。
- (d) 如果您未在拍賣後第三十日曆日或之前提取您購買的**拍賣品**，除非另有書面約定：
- (i) 我們將自拍賣後第 31 日起向您收取倉儲費用。
- (ii) 我們將有權將**拍賣品**移送到關聯公司或第三方倉庫，並向您收取因此產生的運輸費用和處理費用。
- (iii) 我們可以按我們認為商業上合理且恰當的方式出售**拍賣品**。
- (iv) 倉儲的條款適用，條款請見 www.christies.com/storage。
- (v) 本段的任何內容不限制我們在 F4 段下的權利。

H. 運送

1. 運送

運送或付運表格會與發票一同發送給您。您須自行安排**拍賣品**的運送和付運事宜。我們也可以依照您的要求安排包裝運送及付運事宜，但您須支付有關收費。我們建議您在競投前預先查詢有關收費的估價，尤其是需要專業包裝的大件物品或高價值品。應您要求，我們也可建議處理員、包裝、運輸公司或有關專家。

詳情請聯繫佳士得售後服務部，電話：+852 2760 1766 或發電郵至 postsaleasia@christies.com。我們會合理謹慎處理、包裝、運輸**拍賣品**。若我們就上述目的向您推薦任何其他公司，我們不會承擔有關公司之行為，這屬疏忽引致的任何責任。

2. 出口 / 進口

拍賣售出的任何**拍賣品**都可能受**拍賣品**售出國家的出口法律及其他國家的進口法律限制。

許多國家就**拍賣品**出境要求出口聲明及 / 或就**拍賣品**入境要求進口聲明。進口國當地法律可能會禁止進口某些**拍賣品**或禁止**拍賣品**在進口國出售。

我們不會因您所購買的**拍賣品**無法出口，進口或出於任何原因遭政府機構沒收而有責任取消您的購買或向您退換購買款項。您應負責確認並滿足任何法律或法規對出口或進口您購買的**拍賣品**的要求。

- (a) 在競投前，您應尋求專業意見並負責滿足任何法律或法規對出口或進口**拍賣品**的要求。如果您被拒絕許可證，或申請許可證延誤，您仍須全數支付**拍賣品**的價款。如果您提出請求，在我們能力範圍內，我們可以協助您申請所需許可證，但我們會就此服務向您收取費用。我們不保證能獲得許可證。如欲了解詳情，請聯繫佳士得售後服務部，電話：+852 2760 1766 或發電郵至 postsaleasia@christies.com
- (b) 您應負責支付與**拍賣品**出口或進口有關的所有適用稅費、關稅或其他政府徵收的費用。如果佳士得為您出口或進口**拍賣品**，且佳士得支付了上述適用的稅費、關稅或其他政府徵收的費用，您同意向佳士得退還該筆費用。
- (c) **含有受保護動物植物的拍賣品**
由瀕臨絕種及其他受保護野生動物植物製造或組成（不論百分比率）的**拍賣品**在本目錄中註有 [-] 號或 [=] 號並附有以下註腳以供識別：
本手袋，註有 [-] 號，受制於瀕危野生動物種國際貿易公約 (CITES) 出入口限制且無法提供先前的 CITES 歷史證明文件。因此本手袋只可運送至香港境內的地址或從香港佳士得拍賣場提取。本手袋將不能獲取允許其於拍賣後運送至香港境外的 CITES 出口許可證。請與專家部門聯繫以了解詳情。
本手袋，註有 [=] 號，受制於 CITES 出入口限制並須事先獲取 CITES 出口許可證方可將其於拍賣後運送至香港境外。買家須負責取得許可證並支付相關費用。請與專家部門聯繫以了解詳情。
這些物料包括但不限於象牙、玳瑁殼、鱷魚皮、犀牛角、鯨骨、某些珊瑚品種及玫瑰木。若您有意將含有野生動物植物的任何**拍賣品**進口至其他國家，您須於競投該**拍賣品**之前了解有關海關條例和規定。有些國家完全禁止含有這類物料的物品進口，而其他國家則規定須向出口及入口國家的有關管理機構取得許可證。在有些情況下，**拍賣品**必須附有獨立的物種的科學證明和 / 或年期證明，方能裝運，而您須要自行安排上述證明並負責支付有關的費用。如果一件**拍賣品**含有象牙或其他可能和象牙相混淆的野生動物材料（例如猛獁象牙，海象象牙和犀鳥象牙）且您計劃將上述**拍賣品**進口到美國，請查看 (c) 段中之重要信息。如果您無法出口，進口該**拍賣品**或因任何原因**拍賣品**被政府部門查收，我們沒有義務因此取消您的交易並退回您的購買款項。您應負責確定並滿足有關含有上述物料**拍賣品**進出口的法律和規例要求。
- (d) **美國關於非洲象牙的進口禁令**
美國禁止非洲象牙進口美國。如果一件**拍賣品**含有象牙或其他可能和象牙相混淆的野生材料（例如猛獁象牙，海象象牙和犀鳥象牙），其必須通過受美國漁業和野生動物保護局認可的嚴格科學測試確認該物料非非洲

象牙後方可進口美國。如果我們在拍賣前對**拍賣品**已經進行了該嚴格科學測試，我們會在**拍賣品**陳述中清楚表明。我們一般無法確認相關**拍賣品**的象牙是否來自非洲象。您凡購買有關**拍賣品**並計畫將有關**拍賣品**進口到美國，必須承擔風險並負責支付任何科學測試或其他報告的費用。有關測試及無論論或確定物料乃非洲象牙，不被視為取消拍賣和退回購買款項的依據。

(e) 源自伊朗的拍賣品

一些國家禁止或限制購買和 / 或進口源自伊朗的“傳統工藝品”（身份不明確的藝術家作品及 / 或功能性作品。例如：地毯、碗、大口水壺、瓷磚和裝飾盒）。美國禁止進口以上物品亦禁止美國民眾（不論所在處）購買以上物品。有些國家，例如加拿大則允許在某特定情況下可以進口上述物品。為方便買方，佳士得在源自伊朗（波斯）的**拍賣品**下方特別注明。如您受以上制裁或貿易禁運限制，您須確保您不會競投或進口有關**拍賣品**，違反有關適用條例。

(f) 黃金

含量低於 18k 的黃金並不是在所有國家均被視為“黃金”，並可能被拒絕入口。

(g) 鐘錶

本目錄內有些鐘錶的照片顯示該手錶配有瀕危及受保護動物（如短吻鱷或鱷魚）的物料所製成的錶帶。這些**拍賣品**在本目錄內的**拍賣品**編號旁以 **W** 符號顯示。這些錶帶只用來展示**拍賣品**並不作銷售用途。在運送手錶到拍賣地以外的地點前，佳士得會把上述錶帶拆除並予以保存。買方若在拍賣後一年內親身到拍賣所在地的佳士得提取，佳士得可酌情免費提供該展示用但含有瀕危及受保護動物物料之錶帶給買方。

H2 段中的標記是佳士得為了方便閣下而在有關**拍賣品**附加的，附加標記時如有任何錯誤或遺漏，佳士得恕不承擔任何責任。

I. 佳士得之法律責任

- (a) 除了**真品保證**，佳士得、佳士得代理人或僱員，對任何**拍賣品**作任何陳述，或資料的提供，均不作出任何保證。在法律容許的最大程度上，所有由法律附加的保證及其他條款，均被排除在本協議外。在 E1 段中的賣方保證是由賣方提供的保證，我們對這些保證不負有任何責任。
- (b) (i) 除非我們以欺詐手段作出有欺詐成份的失實陳述或在基本業務規定中另有明確說明，我們不會因任何原因對您本有任何責任（無論是因違反本協議，購買**拍賣品**或與競投相關的任何其它事項）；和
(ii) 本公司無就任何**拍賣品**的可售品質、是否適合某特定用途、描述、尺寸、質量、狀況、作品歸屬、真實性、稀有程度、重要性、媒介、來源、展覽歷史、文獻或歷史的關聯等作出任何陳述、保證或擔保或承擔任何責任。除非當地的法律強制要求，任何種類之任何保證，均被本段排除在外。
- (c) 請注意佳士得所提供的書面競投及電話競投服務、Christie's LIVE™、狀況報告、貨幣兌換顯示板及拍賣室錄像影像為免費服務，如有任何錯誤（人為或其其原因）、遺漏或故障或延誤、未能提供、暫停或終止，本公司不負責任何責任。
- (d) 就**拍賣品**購買的事宜，我們僅對買方負有法律責任。
- (e) 如果儘管有 (a) 至 (d) 或 E2(i) 段的規定，我們因某些原因須對您負上法律責任，我們不須支持超過您已支付的購買款項。佳士得不須就任何利潤或經營損失、商機喪失或價值、預期存款或利息、費用、賠償或支出等原因負上任何責任。

J. 其它條款

1. 我們的撤銷權
除了本協議中的其他撤銷權利，如果我們合理地認為完成交易可能是違法行為或該銷售會令我們或賣方向任何人負上法律責任或損壞我們的名聲，我們可取消該**拍賣品**的拍賣。
2. 錄像
我們可以錄影及記錄拍賣過程。除非按法律要求，我們會對個人信息加以保密。該資料可能用於或提供其他佳士得集團公司和市場夥伴以作客戶分析或以便我們向買方提供合適的服務。若您不想被錄影，您可透過電話或書面競投或在 Christie's LIVE™ 競投。除非另有書面約定，您不能在拍賣現場錄像或錄音。
3. 版權
所有由佳士得或為佳士得與**拍賣品**有關之製作之一切圖片、插圖與書面資料（除有特別註釋外，包括我們的事先目錄的內容）之版權均屬於佳士得所有。沒有我們的事先書面許可不得使用以上版權作品。我們沒有保證您就投得的**拍賣品**會取得任何版權或其他複製的權利。
4. 效力
如本協議的任何部份遭任何法院認定為無效、不合法或無法執行，則該部分應被視為刪除，其它部分不受影響。

5. 轉讓您的權利及責任
除非我們給予書面許可，否則您不得就您在本協議下的權利或責任設立任何抵押，亦不得轉讓您的權利和責任。本協議對您的繼任人、遺產及任何承繼閣下責任的人具有約束力。
6. 翻譯
如果我們提供了本協議的翻譯件，我們將會使用英文版用於解決本協議項下產生的任何問題以及爭議。
7. 個人信息
您同意我們將持有並處理您的個人數據或信息，並將其交給其它佳士得集團公司用於我們的私隱政策所描述的，或與其相符的目的。您可以在 www.christies.com 上找到本公司私隱政策。
8. 棄權
未能或延遲行使本業務規定下的權利或補償不應被視為免除該權利或補償，也不應阻止或限制對該權利或補償或其他權利或補償的行使。單獨或部分行使該權利或補償不應阻止或限制對其它權利或補償的行使。
9. 法律及管轄權
各方的權利及義務，就有關本業務規定，拍買的行為及任何與上述條文的事項，均受香港法律管轄及根據香港法律解釋。在拍賣競投時，無論是親自出席或由代理人出席競投，書面、電話及其他方法競投，買方則被視為接受本業務規定，及為佳士得之利益而言，接受香港法院之排他性管轄權，並同時接納佳士得亦擁有權在任何其它司法管轄區提出索償，以追討買方拖欠的任何款項。
10. www.christies.com 的報告
售出的**拍賣品**的所有資料，包括目錄描述及價款都可在 www.christies.com 上查閱。銷售總額為成交價加上買方酬金，並不反映成本、財務費用或買方或賣方信貸申請情況。我們不能按要求將這些資料從 www.christies.com 網站上刪除。

K. 詞匯表

- 拍賣官**：個人拍賣官 / 或佳士得。
真品：以下所述的真實作品，而不是複製品或贗品：
a) **拍賣品**在標題被描述為某位藝術家、作者或製作者的作品，則為該藝術家、作者或製造者的作品；
b) **拍賣品**在標題被描述為是某時期或流派創作的作品，則該時期或流派的作品；
c) **拍賣品**在標題被描述為某來源，則為該來源的作品；
d) 以寶石為例，如**拍賣品**在標題被描述為由某種材料製成，則該作品是由該材料製成。
真品保證：我們在本協議 E 段所詳述為**拍賣品**提供的保證。
買方酬金：除了成交價，買方支付給我們的費用。
目錄描述：拍賣目錄內對**拍賣品**的陳述（包括於拍賣場通過對有關陳述作出的任何更改）。
佳士得集團：Christie's International Plc、其子公司及集團的其它公司。
狀況：**拍賣品**的物理狀況。
到期付款日：如第 F1(a) 段所列出的意思。
估價：目錄中或拍賣場通告中列明的我們認為**拍賣品**可能出售的價格範圍。**低端估價**指該範圍的最低價；**高端估價**指該範圍的最高價。**中間估價**為兩者的中間點。
成交價：**拍賣官**接受的**拍賣品**最高競投價。
標題：如 E2 段所列出的意思。
拍賣品：供拍賣的一件**拍賣品**（或作為一組拍賣的兩件或多件的物件）；
其他賠償：任何特殊、連帶、附帶或間接的賠償或任何符合當地法律規定的“特殊”、“附帶”或“連帶”賠償。
購買款項：如第 F1(a) 段的意思。
來源：**拍賣品**的所有權歷史。
有保留：如 E2 段中的意思；**有保留標題**則指目錄中“重要通知和目錄編制說明”頁中的“有保留標題”的意思。
底價：**拍賣品**不會以低於此保密底價出售。
拍賣場通告：張貼位於拍賣場內外的**拍賣品**旁或 www.christies.com 的書面通知（上述通知內容會另行通知以電話或書面競投的客戶），或拍賣會舉行前或拍賣某**拍賣品**前**拍賣官**宣布的公告。
大略字體：指包含所有的大寫字母。
保證：陳述人或聲明人保證其所陳述或聲明的事實為正確。

LEVEL/ULLAGE DESCRIPTIONS AND INTERPRETATIONS

(see notes below)

BORDEAUX

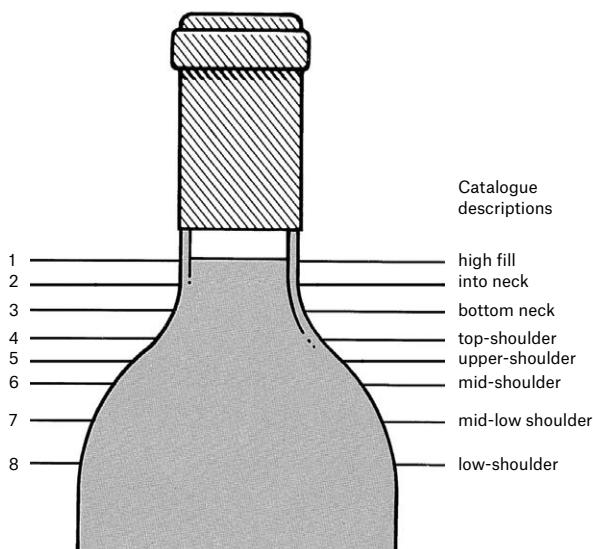

Catalogue descriptions

- 1 high fill into neck
- 2 bottom neck
- 3 top-shoulder
- 4 upper-shoulder
- 5 mid-shoulder
- 6 mid-low shoulder
- 7 low-shoulder
- 8

BURGUNDY

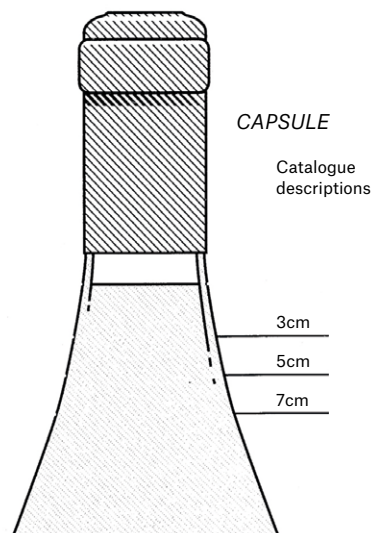

CAPSULE

Catalogue descriptions

- 3cm
- 5cm
- 7cm

- 1 into neck: Level of young wines. Exceptionally good in wines over 10 years old.
- 2 bottom neck: Perfectly good for any age of wine. Outstandingly good for a wine of 20 years in bottle, or longer.
- 3 very top-shoulder
- 4 top-shoulder: Normal for any claret 15 years old or older.
- 5 upper-shoulder: Slight natural reduction through the easing of the cork and evaporation through cork and capsule. Usually no problem. Acceptable for any wine over 20 years old. Exceptional for pre-1950 wines.

- 6 mid-shoulder: Probably some weakening of the cork and some risk. Not abnormal for wines 30/40 years of age. Estimates usually take this into account.
- 7 mid-low-shoulder: Some risk. Low estimates.
- 8 low-shoulder: Risky and usually only accepted for sale if wine or label exceptionally rare or interesting. Always offered with low estimate.

Because of the slope of shoulder it is impractical to describe levels as mid-shoulder, etc. Wherever appropriate the level between cork and wine will be measured and catalogued in centimetres.

The condition and drinkability of burgundy is less affected by ullage than its equivalent from Bordeaux. For example, a 5 to 7 cm. ullage in a 30-year-old burgundy can be considered normal, indeed good for age, 3.5 to 4 cm. excellent for age, even 7cm. rarely a risk.

BOTTLE SIZES

- magnum = two regular bottles (1.5L)
- marie-jeanne = three regular bottles (2.5L)
- double-magnum = four regular bottles (3L)
- jeroboam = four regular bottles (3L)
(Burgundy, Champagne)
- jeroboam = six regular bottles (5L)
(Bordeaux)
(or 5 litres)
- impériale = eight regular bottles (6L)
(Bordeaux)
- methuselah = eight regular bottles (6L)
(Burgundy)
- balthazar = sixteen regular bottles (12L)
- nebuchadnezzar = twenty regular bottles (15L)
- melchior = twenty-four regular bottles (18L)

SPECIAL NOTICE

Though every effort is made to describe or measure the levels of older vintages, corks over 20 years old begin to lose their elasticity and levels can change between cataloguing and sale. Old corks have also been known to fail during or after shipment. **We therefore repeat that there is always a risk of cork failure with old wines and due allowance must be made for this. Under no circumstances can an adjustment of price or credit be made after delivery except under the terms stated in Paragraph I of the Conditions of Sale - Buying at Christie's. Unless otherwise stated, Bordeaux are château bottled and all wines are bottled in the country of production.**

Important note regarding opening of cases and listing of levels: Christie's general policy is to open all wood cases and to describe levels. Bidders must make allowances for reasonable variations in ullage which may be encountered in cases older than twenty years. Additionally, all wine younger than twenty years have levels bottom neck or better unless otherwise noted.

狀況 / 損耗量形容及解釋

(請細閱以下)

波爾多

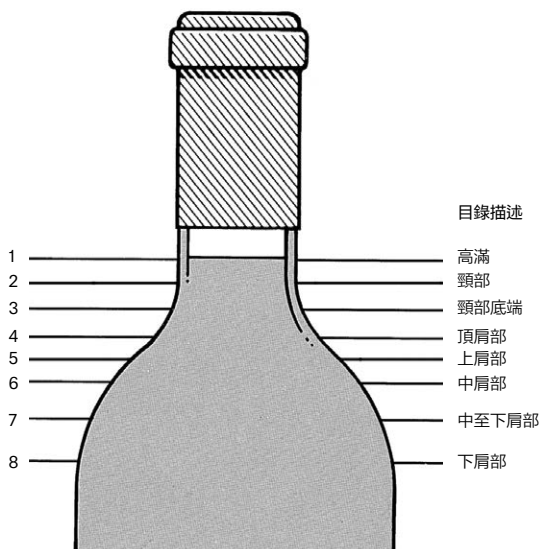

目錄描述

- 1 頸部：
新酒的正常水位。若酒齡超過 10 年的酒還保持這水位，是非常好的。
- 2 頸部底端：
對任何酒齡的酒來說，都是很好的，尤其是如酒齡是超過 20 年的酒。
- 3 最頂肩部
- 4 頂肩部：
正常的如酒齡是 15 年或以上。
- 5 上肩部：
因酒塞鬆懈及蒸發以至有少許自然的退減，一般是沒有問題的。可接受如酒齡超過 20 年。

- 6 中肩部：
酒塞可能有一些削弱，有一些風險，不是異常的如酒齡到達 30/40 年。估值通常會把此計算在內。
- 7 中至低肩部：
有些風險，低估值。
- 8 低肩部：
高風險及一般只會售賣當酒或招紙是很稀有或珍貴。常常也是低估值。

勃根地

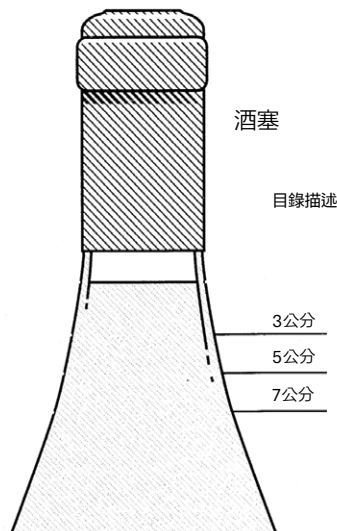

酒塞

目錄描述

由於肩部的斜度並不能夠形容中肩等的水位，在可能的情況下酒塞及名酒之間的距離將會以厘米量度及收錄。

勃根地酒的狀況及可飲用程度，較之於波爾多酒，較少受自然耗損影響。例如酒齡為三十年的勃根地酒有 5 至 7 厘米的自然耗損可視為正常。酒齡良好的，會有 3.5 至 4 厘米的自然耗損，酒齡超卓的甚至會有 7 厘米的自然耗損，很少具有風險。

酒瓶大小

magnum	= 2 個標準瓶 (1.5 公升)
marie-jeanne	= 3 個標準瓶 (2.5 公升)
double-magnum	= 4 個標準瓶 (3 公升)
jeroboam (Burgundy, Champagne)	= 4 個標準瓶 (3 公升)
jeroboam (Bordeaux)	= 6 個標準瓶 (5 公升) (或 5 升)
impériale (Bordeaux)	= 8 個標準瓶 (6 公升)
methuselah (Burgundy)	= 8 個標準瓶 (6 公升)
balthazar	= 16 個標準瓶 (12 公升)
nebuchadnezzar	= 20 個標準瓶 (15 公升)
melchior	= 24 個標準瓶 (18 公升)

特別通告

儘管已盡一切辦法去形容或量度較舊名酒的水位，超過 20 年的酒塞亦會開始失去其彈性，水位可能在收錄目錄及銷售期間改變。舊酒塞亦已知可能在運送或運抵後失效。佳士得因此重申舊酒的酒塞經常有損壞的風險，必須對此有適當的寬容。除出現在業務規定·買方須知第 1 段的情況，在任何情況下，在運送後均不可調整價格或退款。除註明外，所有波爾多酒均於莊園裝瓶，所有名酒均在生產國裝瓶。

有關打開酒箱及列明水位的重要註釋：佳士得一般的政策是打開所有木酒箱，並說明水位。按標者必須對酒齡 20 年及以上的名酒可能出現的自然耗損的合理差異有所寬容。此外，除另有註明，所有酒齡 20 年以下的名酒均有頸部底端或更佳的水位。

SYMBOLS USED IN THIS CATALOGUE

The meaning of words coloured in **bold** in this section can be found at the end of the section of the catalogue headed 'Conditions of Sale • Buying at Christie's'

◦ Christie's has a direct financial interest in the **lot**. See Important Notices and Explanation of Cataloguing Practice.

△ Owned by Christie's or another **Christie's Group** company in whole or part. See Important Notices and Explanation of Cataloguing Practice.

◆ Christie's has a direct financial interest in the **lot** and has funded all or part of our interest with the help of someone else. See Important Notices and Explanation of Cataloguing Practice.

✠ Bidding by parties with an interest.

• **Lot** offered without **reserve** which will be sold to the highest bidder regardless of the pre-sale estimate in the catalogue.

~ **Lot** incorporates material from endangered species which could result in export restrictions. See Section H2(b) of the Conditions of Sale • Buying at Christie's.

Ψ **Lot** incorporates material from endangered species that is not for sale and is shown for display purposes only.

Please note that **lots** are marked as a convenience to you and we shall not be liable for any errors in, or failure to, mark a **lot**.

本目錄中使用的各類標識

本部份粗體字體詞語的涵義載於本目錄中題為“業務規定·買方須知”一章的最後一頁。

◦ 佳士得對該**拍賣品**擁有直接經濟利益。請參閱重要通知及目錄編列方法之說明。

△ 全部或部分由佳士得或其他**佳士得集團**公司持有。請參閱重要通知及目錄編列方法之說明。

◆ 佳士得對該**拍賣品**擁有直接經濟利益，佳士得的全部或部分利益通過第三方融資。請參閱重要通知及目錄編列方法之說明。

✠ 利益方的競投。

• 不設**底價**的**拍賣品**，不論其在本目錄中的售前估價，該**拍賣品**將售賣給出價最高的競投人。

~ **拍賣品**含有瀕危物種的材料，可能受出口限制。請參閱業務規定·買方須知第 H2(b) 段。

Ψ **拍賣品**含有瀕危物種的材料，只用作展示用途，並不作銷售。

請注意對藏品的標記僅為您提供方便，本公司不承擔任何因標示錯誤或遺漏標記的責任。

IMPORTANT NOTICES AND EXPLANATION OF CATALOGUING PRACTICE

IMPORTANT NOTICES

CHRISTIE'S INTEREST IN PROPERTY CONSIGNED FOR AUCTION

△: Property Owned in part or in full by Christie's

From time to time, Christie's may offer a lot which it owns in whole or in part. Such property is identified in the catalogue with the symbol △ next to its lot number. Where Christie's has an ownership or financial interest in every lot in the catalogue, Christie's will not designate each lot with a symbol, but will state its interest in the front of the catalogue.

◦ Minimum Price Guarantees:

On occasion, Christie's has a direct financial interest in the outcome of the sale of certain lots consigned for sale. This will usually be where it has guaranteed to the Seller that whatever the outcome of the auction, the Seller will receive a minimum sale price for the work. This is known as a minimum price guarantee. Where Christie's holds such financial interest we identify such lots with the symbol ◦ next to the lot number.

◦◆ Third Party Guarantees/Irrevocable bids

Where Christie's has provided a Minimum Price Guarantee it is at risk of making a loss, which can be significant, if the lot fails to sell. Christie's therefore sometimes chooses to share that risk with a third party who agrees prior to the auction to place an irrevocable written bid on the lot. If there are no other higher bids, the third party commits to buy the lot at the level of their irrevocable written bid. In doing so, the third party takes on all or part of the risk of the lot not being sold. Lots which are subject to a third party guarantee arrangement are identified in the catalogue with the symbol ◦◆.

Christie's compensates the third party in exchange for accepting this risk provided that the third party is not the successful bidder. The remuneration to the third party may either be based on a fixed fee or an amount calculated against the final hammer price. The third party may also bid for the lot above the irrevocable written bid. Where the third party is the successful bidder, the third party is required to pay the hammer price and the buyer's premium in full.

Third party guarantors are required by us to disclose to anyone they are advising their financial interest in any lots they are guaranteeing. However, for the avoidance of any doubt, if you are advised by or bidding through an agent on a lot identified as being subject to a third party guarantee you should always ask your agent to confirm whether or not he or she has a financial interest in relation to the lot.

✠ Bidding by parties with an interest

When a party with a direct or indirect interest in the lot who may have knowledge of the lot's reserve or other material information may be bidding on the lot, we will mark the lot with this symbol ✠. This interest can include beneficiaries of an estate that consigned the lot or a joint owner of a lot. Any interested party that successfully bids on a lot must comply with Christie's Conditions of Sale, including paying the lot's full Buyer's Premium plus applicable taxes.

Post-catalogue notifications

In certain instances, after the catalogue has been published, Christie's may enter into an arrangement or become aware of bidding that would have required a catalogue symbol. In those instances, a pre-sale or pre-lot announcement will be made.

Other Arrangements

Christie's may enter into other arrangements not involving bids. These include arrangements where Christie's has given the Seller an Advance on the proceeds of sale of the lot or where Christie's has shared the risk of a guarantee with a partner without the partner being required to place an irrevocable written bid or otherwise participating in the bidding on the lot. Because such arrangements are unrelated to the bidding process they are not marked with a symbol in the catalogue.

Please see <http://www.christies.com/financial-interest/> for a more detailed explanation of minimum price guarantees and third party financing arrangements.

FOR PICTURES, DRAWINGS, PRINTS AND MINIATURES, SCULPTURES, INSTALLATION, VIDEO, CALLIGRAPHY AND PAINTED CERAMIC

Terms used in this catalogue have the meanings ascribed to them below. Please note that all statements in this catalogue as to authorship are made subject to the provisions of the Conditions of Sale and authenticity warranty. Buyers are advised to inspect the property themselves. Written condition reports are usually available on request.

QUALIFIED HEADINGS

In Christie's opinion a work by the artist.

*"Attributed to ..."

In Christie's qualified opinion probably a work by the artist in whole or in part.

**"Studio of ..."/ "Workshop of ..."

In Christie's qualified opinion a work executed in the studio or workshop of the artist, possibly under his supervision.

“Circle of ...”

In Christie's qualified opinion a work of the period of the artist and showing his influence.

“Follower of ...”

In Christie's qualified opinion a work executed in the artist's style but not necessarily by a pupil.

“Manner of ...”

In Christie's qualified opinion a work executed in the artist's style but of a later date.

“After ...”

In Christie's qualified opinion a copy (of any date) of a work of the artist.

“Signed ...”/“Dated ...”/

“Inscribed ...”

In Christie's qualified opinion the work has been signed/dated/inscribed by the artist.

“With signature ...”/“With date ...”/

“With inscription ...”

In Christie's qualified opinion the signature/date/inscription appears to be by a hand other than that of the artist.

The date given for Old Master, Modern and Contemporary Prints is the date (or approximate date when prefixed

with 'circa') on which the matrix was worked and not necessarily the date when the impression was printed or published.

*This term and its definition in this Explanation of Cataloguing Practice are a qualified statement as to authorship. While the use of this term is based upon careful study and represents the opinion of specialists, Christie's and the consignor assume no risk, liability and responsibility for the authenticity of authorship of any lot in this catalogue described by this term, and the Authenticity Warranty shall not be available with respect to lots described using this term.

OPTIONS TO BUY PARCELS

A parcel consists of several lots of the same wine of identical lot size, bottle size and description. Bidding will start on the first lot of the parcel and the successful buyer of that lot is entitled to take some or all of the remaining lots in the parcel at the same hammer price. If the buyer of the first lot does not take further lots, the remaining lots of the parcel will be offered in a similar fashion. We recommend that a bid on a parcel lot be placed on the first lot of the parcel. If the bid is superseded, Christie's will automatically move your bid

to the next identical lot and so on. In all instances, such bids will be handled at the auctioneer's discretion.

CLASSIFICATIONS

Bordeaux Classifications in the text are for identification purposes only and are based on the official 1855 classification of the Médoc and other standard sources. All wines are Château-bottled unless stated otherwise.

ULLAGES AND CORKS OF OLD WINES

Wines are described in this catalogue as correctly as can be ascertained at time of going to press, but buyers of old wines must make appropriate allowances for natural variations of ullages, conditions of cases, labels, corks and wine. No returns will be accepted.

ULLAGE

The amount by which the level of wine is short of being full: these levels may vary according to age of the wines and, as far as can be ascertained by inspection prior to the sale, are described in the catalogue. A chart explaining level and ullage descriptions and interpretations, together with a visual presentation, appears in this catalogue. We hope you will find this helpful.

重要通知及目錄編列方法之說明

重要通告

佳士得在受委託拍賣品中的權益

▲: 部分或全部歸佳士得擁有的拍賣品

佳士得可能會不時提供佳士得集團旗下公司全部或部分擁有之拍賣品。該等拍賣品在目錄中於拍賣編號旁註有 ▲ 符號以資識別。如果佳士得在目錄中每一項拍賣品中均有所有權或經濟利益，佳士得將不會於每一項拍賣品旁附注符號，但會於正文首頁聲明其權益。

◦ 保證最低出售價

佳士得有時就某些受委託出售的拍賣品的拍賣成果持有直接的經濟利益。通常為其向賣方保證無論拍賣的結果如何，賣方就拍賣品的出售獲得最低出售價。這被稱為保證最低出售價。該等拍賣品在目錄中於拍賣編號旁註有 ◦ 號以資識別。

◦◆ 第三方保證 / 不可撤銷的競投

在佳士得已經提供最低出售價保證，如果拍賣品未能出售，佳士得將承擔遭受重大損失的風險。因此，佳士得有時選擇與同意在拍賣之前就該拍賣品提交一份不可撤銷的書面競投的第三方擔保風險。如果沒有其他更高的競價，第三方承諾將以他們提交的不可撤銷的書面競投價格購買該拍賣品。第三方因此承擔拍賣品未能出售的所有或部分風險。如果拍賣品未能出售，第三方可能承擔損失。該等拍賣品在目錄中註以符號 ◦◆ 以資識別。

第三方需要承擔風險，在自身不是成功競投人的情況下，佳士得將給予酬金給第三方。第三方的酬金可以是固定金額或基於成交價計算的酬金。第三方亦可以就該拍賣品以超過書面競投的不可撤銷的價格進行競投。如果第三方成功競投，第三方必須全額支付成交價及買方酬金。

我們要求第三方保證人向其客戶披露在給予保證的拍賣品持有的經濟利益。如果您通過顧問意見或委託代理人競投一件標示為有第三方融資的拍賣品，我們建議您應當要求您的代理人確認他 / 她是否在拍賣品持有經濟利益。

✶ 利益方的競投

當那些可能獲悉了拍賣品的底價或其他重要信息對拍賣品擁有直接或間接權益的一方可能進行競投時，我們會對該拍賣品附注符號 ✶。該利益可包括委託出售拍賣品的遺產受益人或者拍賣品的共同所有人之一。任何成功競得拍賣品的利益方必須遵守佳士得的業務規定，包括全額支付拍賣品的買方酬金及適用的稅費。

目錄出版後通知

在有些情形下，在目錄出版後，佳士得可能會達成某種安排或意識到有需要附注目錄符號的競投。在此情況下，我們會在拍賣會前或拍賣該項拍賣品前做出通知。

其他安排

佳士得可能訂立與競投無關的協議。這些協議包括佳士得向賣方就拍賣品銷售所得預付金額或者佳士得與第三方擔保風險，但並不要求第三方提供不可撤銷的書面競投或參與拍賣品的競投。因為上述協議與競投過程無關，我們不會在目錄中註以符號。

請登錄 <http://www.christies.com/financial-interest/> 瞭解更多關於最低出售價保證以及第三方融資安排的說明。

有關繪畫、素描、版畫、小型畫、雕塑、裝置、錄像、書法及手繪瓷器

下列詞語於本目錄中具有以下意義。請注意本目錄中有關作者身份的所有聲明均按照本公司之業務規定及真品保證的條款而作出。

買方應親自檢視各拍賣品的狀況，亦可向佳士得要求提供書面狀況報告。

有保留的標題

佳士得認是屬於該藝術家之作品

*「傳」、「認為是...之作品」

指以佳士得有保留之意見認為，某作品大概全部或部份是藝術家之創作。

*「...之創作室」及「...之工作室」

指以佳士得有保留之意見認為，某作品在某藝術家之創作室或工作室完成，可能在他監督下完成。

*「...時期」

指以佳士得有保留之意見認為，某作品屬於該藝術家時期之創作，並且反映出該藝術家之影響。

*「跟隨...風格」

指以佳士得有保留之意見認為，某作品具有某藝術家之風格，但未必是該藝術家門生之作品。

*「具有...創作手法」

指以佳士得有保留之意見認為，某作品具有某藝術家之風格，但於較後時期完成。

*「...複製品」

指以佳士得有保留之意見認為，某作品是某藝術家作品之複製品（任何日期）。

*「簽名...」、「日期...」、「題寫...」

指以佳士得有保留之意見認為，某作品由某藝術家簽名 / 寫上日期 / 題詞。

*「附有...簽名」、「附有...之日期」、「附有...之題詞」、「款」

指以佳士得有保留之意見認為某簽名 / 某日期 / 題詞應不是某藝術家所為。

古代、近現代印刷品之日期是指製造作品之日期 [或大概日期] 而不一定是作品印刷或出版之日。

* 於本目錄編列方法之說明中此詞語及其定義為對作者身份而言之有限說明。雖然本詞語之使用，乃基於審慎研究及代表專家之意見，佳士得及委託人於目錄內使用此詞語及其所描述之拍賣品及其作者身份之真確及可信性，並不承擔及接受任何風險、義務或責任，而真品保證條款，亦不適用於以此詞語所描述之拍賣品。

購買一系列貨批的選擇權

一組貨批內含多批相同批量、瓶容量及種類的名酒。競投將會由一系列貨批之中的第一貨批開始。成功競投的買家有權以相同的成交價購入系列中部分或全部貨批。若果第一貨批的買家未有進一步購入，該系列貨批的餘下貨批將會相似的方式開放競投。佳士得建議對貨批的出價應在該系列貨批的第一貨批之上。如果出價被取代，佳士得將會自動把買家的出價置在下一相同貨批，如此類推。在所有情況下，有關出價均全權由拍賣官處理。

分類

內容中的波爾多分類標準僅作識別之用，並且根據 Médoc 1855 年正式的分類標準及其他標準來源。除註明外，所有名酒均在莊園內裝瓶。

舊酒的自然耗損及酒塞

在本目錄內列明的名酒均在印刷前確定內容正確，惟舊酒買家必須對自然程度的耗損、酒箱狀況、標籤、酒塞及名酒的差異作出包容。恕不接受退貨。

耗損

名酒水位未能達至滿的水位之差距，有關差距會根據名酒之年期而有所不同，而在銷售前能通過檢驗確定的，均會在目錄中註明。本目錄以圖表的形式詳細說明水位與損耗量形容及解釋以方便閣下參考。

WORLDWIDE SALEROOMS AND OFFICES AND SERVICES

ARGENTINA

BUENOS AIRES
+54 11 43 93 42 22
Cristina Carlisle

AUSTRALIA

SYDNEY
+61 (0)2 9326 1422
Ronan Sulich

AUSTRIA

VIENNA
+43 (0)1 533 881214
Angela Baillou

BELGIUM

BRUSSELS
+32 (0)2 512 88 30
Roland de Lathuy

BRAZIL

SÃO PAULO
+55 21 3500 8944
Marina Bertoldi

CANADA

TORONTO
+1 647 519 0957
Brett Sherlock
(Consultant)

CHILE

SANTIAGO
+56 2 2 2631642
Denise Ratnoff
de Lira

COLOMBIA

BOGOTA
+571 635 54 00
Juanita Madrinan
(Consultant)

DENMARK

COPENHAGEN
+ 45 2612 0092
Rikke Juel Brandt
(Consultant)

FRANCE

**BRITTANY AND
THE LOIRE VALLEY**
+33 (0)6 09 44 90 78
Virginie Gregory
(Consultant)

GREATER EASTERN FRANCE

+33 (0)6 07 16 34 25
Jean-Louis Janin Daviet
(Consultant)

NORD-PAS DE CALAIS

+33 (0)6 09 63 21 02
Jean-Louis Brémilts
(Consultant)

•PARIS

+33 (0)1 40 76 85 85

PROVENCE - ALPES CÔTE D'AZUR

+33 (0)6 71 99 97 67
Fabienne Albertini-Cohen

RHÔNE ALPES

+33 (0)6 61 81 82 53
Dominique Pierron
(Consultant)

GERMANY

DÜSSELDORF
+49 21 14 91 59 352
Arno Verkade

FRANKFURT

+49 (0)170 840 7950
Natalie Radziwill

HAMBURG

+49 (0)40 27 94 073
Christiane Gräfin
zu Rantzau

MUNICH

+49 (0)89 24 20 96 80
Marie Christine Gräfin
Huyt

STUTTGART

+49 (0)71 12 26 96 99
Eva Susanne
Schweizer

INDIA

MUMBAI
+91 (22) 2280 7905
Sonal Singh

INDONESIA

JAKARTA
+62 (0)21 7278 6268
Charmie Hamami

ISRAEL

TEL AVIV
+972 (0)3 695 0695
Roni Gilat-Baharaff

ITALY

MILAN
+39 02 303 2831
Cristiano De Lorenzo

ROME

+39 06 686 3333
Marina Cicogna
(Consultant)

NORTH ITALY

+39 348 3131 021
Paola Gradi
(Consultant)

TURIN

+39 347 2211 541
Chiara Massimello
(Consultant)

VENICE

+39 041 277 0086
Bianca Arrivabene Valenti
Gonzaga (Consultant)

BOLOGNA

+39 051 265 154
Benedetta Possati Vittori
Venenti (Consultant)

GENOA

+39 010 245 3747
Rachele Guicciardi
(Consultant)

FLORENCE

+39 055 219 012
Alessandra Niccolini di
Camugliano (Consultant)

CENTRAL & SOUTHERN ITALY

+39 348 520 2974
Alessandra Allaria
(Consultant)

JAPAN

TOKYO
+81 (0)3 6267 1766
Katsura Yamaguchi

MALAYSIA

KUALA LUMPUR
+62(0)21 7278 6268
Charmie Hamami

MEXICO

MEXICO CITY
+52 55 5281 5446
Gabriela Lobo

MONACO

+377 97 97 11 00
Nancy Dotta

THE NETHERLANDS

•AMSTERDAM
+31 (0)20 57 55 255
Arno Verkade

NORWAY

OSLO
+47 949 89 294
Cornelia Svedman
(Consultant)

PEOPLE'S REPUBLIC OF CHINA

BEIJING
+86 (0)10 8583 1766
Julia Hu

•HONG KONG

+852 2760 1766

•SHANGHAI

+86 (0)21 6355 1766
Julia Hu

PORTUGAL

LISBON
+351 919 317 233
Mafalda Pereira Coutinho
(Consultant)

RUSSIA

MOSCOW
+7 495 937 6364
+44 20 7389 2318
Zain Talyarkhan

SINGAPORE

SINGAPORE
+65 6735 1766
Jane Ngiam

SOUTH KOREA

SEOUL
+82 2 720 5266
Jun Lee

SPAIN

MADRID
+34 (0)91 532 6626
Carmen Schjaer
Dalia Padilla

SWEDEN

STOCKHOLM
+46 (0)73 645 2891
Claire Ahman
(Consultant)
+46 (0)70 9369 201
Louise Dyhlén
(Consultant)

SWITZERLAND

•GENEVA
+41 (0)22 319 1766
Eveline de Proyart

•ZURICH

+41 (0)44 268 1010
Jutta Nixdorf

TAIWAN

TAIPEI
+886 2 2736 3356
Ada Ong

THAILAND

BANGKOK
+66 (0)2 252 3685
Prapavadee
Sophonpanich

TURKEY

ISTANBUL
+90 (532) 558 7514
Eda Kehale Argün
(Consultant)

UNITED ARAB EMIRATES

•DUBAI
+971 (0)4 425 5647

UNITED KINGDOM

•LONDON
+44 (0)20 7839 9060

NORTH AND NORTHEAST

+44 (0)20 7104 5702
Thomas Scott

NORTHWEST AND WALES

+44 (0)20 7752 3033
Jane Blood

SOUTH

+44 (0)1730 814 300
Mark Wrey

SCOTLAND

+44 (0)131 225 4756
Bernard Williams
Robert Lagneau
David Bowes-Lyon
(Consultant)

ISLE OF MAN

+44 (0)20 7389 2032

CHANNEL ISLANDS

+44 (0)20 7389 2032

IRELAND

+353 (0)87 638 0996
Christine Ryall
(Consultant)

UNITED STATES

CHICAGO
+1 312 787 2765
Catherine Busch

DALLAS

+1 214 599 0735
Caper Ryan

HOUSTON

+1 713 802 0191
Jessica Phifer

LOS ANGELES

+1 310 385 2600
Sonya Roth

MIAMI

+1 305 445 1487
Jessica Katz

•NEW YORK

+1 212 636 2000
PALM BEACH
+1 561 777 4275
David G. Ober
(Consultant)

SAN FRANCISCO

+1 415 982 0982
Ellanor Notides

AUCTION AND OTHER SERVICES

PRIVATE SALES

HK: +852 2978 6871
Fax: +852 2760 1767
Email: privatesaleservicecentre@christies.com

CHRISTIE'S EDUCATION

NEW YORK
Tel: +1 212 355 1501
Fax: +1 212 355 7370
Email: newyork@christies.edu

HONG KONG

Tel: +852 2978 6768
Fax: +852 2525 3856
Email: hongkong@christies.edu

LONDON

Tel: +44 (0)20 7665 4350
Fax: +44 (0)20 7665 4351
Email: london@christies.edu

CHRISTIE'S INTERNATIONAL REAL ESTATE

NEW YORK
Tel: +1 212 468 7182
Fax: +1 212 468 7141
Email: info@christiesrealestate.com

LONDON

Tel: +44 (0)20 7389 2551
Fax: +44 (0)20 7389 2168
Email: info@christiesrealestate.com

HONG KONG

Tel: +852 2978 6788
Fax: +852 2760 1767
Email: info@christiesrealestate.com

CHRISTIE'S FINE ART STORAGE SERVICES

NEW YORK
Tel: +1 212 974 4579
Email: newyork@cfass.com

• DENOTES SALEROOM

ENQUIRIES — Call the Saleroom or Office

EMAIL — info@christies.com

For a complete salerooms & offices listing go to christies.com

15/07/19

CHRISTIE'S HONG KONG WINE STORAGE AND COLLECTION

All wines offered for auction in this catalogue are lying in Christie's appointed cellar, Crown Wine Cellars.

Buyers wishing to collect from the storage facility directly may do so by prior arrangement. Crown Wine Cellars will only release the lots upon your signature of a Christie's Collection Order. Request for deliveries can be made after receipt of cleared funds and must be at least 2 business days prior to date of delivery. All shipping charges, local delivery charges, transit insurance and packing will be at the expense of the buyers. All charges will have to be prepaid to Christie's before shipment can be effected. All breakages or missing bottles must be reported to Christie's within three days of collection or delivery of the wine lots. To arrange the pick-up or delivery of your purchase, please contact Mr. Kelvin Pun or Ms. Angel Lam of Crown Wine Cellars at +852 2453 3530.

If lots are not collected within thirty calendar days following the sale, Crown Wine Cellars Limited will charge you and you will have to pay all storage charges incurred from the thirty-first calendar day following the sale for the period while the lot(s) are stored at Crown Wine Cellars Limited's storage facility. Crown Wine Cellars Limited will invoice the buyers directly. Buyers agree that Christie's will provide the buyers' contact details to Crown Wine Cellars Limited for the purposes of invoicing and collection of storage fees.

Local Delivery Charges for normal orders (All prices are subject to change)

Urgent, express orders and other areas not mentioned below will be quoted separately.

Delivery/Collection			
Bottle	Hong Kong Island	Kowloon & New Territories	Discovery Bay, Ma Wan, Tung Chung & Lantau Island
1-6	HKD320	HKD220	HKD340
7-12	HKD370	HKD280	HKD400
13-48	HKD480	HKD380	HKD500
49-240	HKD660	HKD560	HKD680

* For 241 bottles and above, please contact Crown Wine Cellars at Tel: +852 2453 3530.
 ** Delivery Charges include insurance.

Delivery Schedule: Monday to Friday 11:00-17:00
 Saturday before 12:00

The storage facility information is listed below:

Storage Facility (Tuen Mun)

Contact: Mr. Kelvin Pun (kpun@crownew.com)
 Ms. Angel Lam (angellam@crownew.com)
 Tel: +852 2453 3530
 Address: 1/F, Crown Data Centre 1,
 6 Kin Fung Circuit, Tuen Mun, NT, HK

Office Hours: Monday to Friday 10:00-12:30 and 14:00-17:30
 Saturday 10:00-12:30

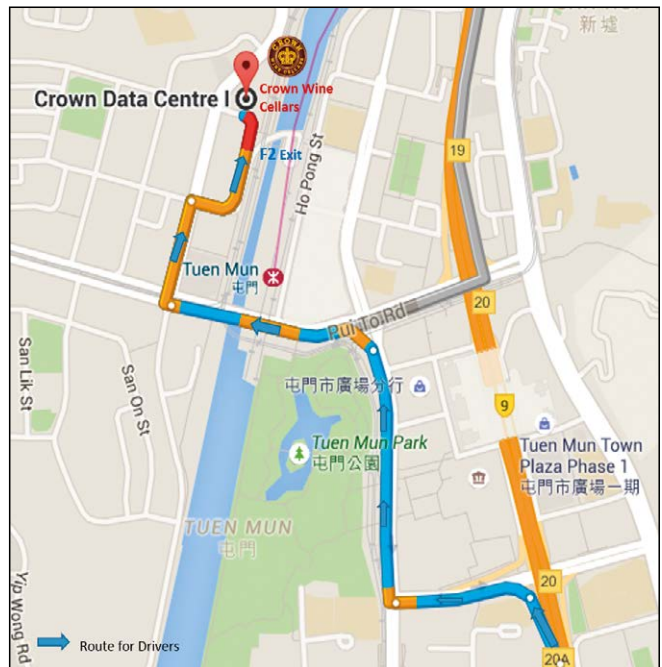

Overseas Delivery

For designated countries, Christie's will be pleased to assist with making arrangements for the packing, shipping and transit insurance of the purchased lots at the buyer's request and expense upon receipt of all outstanding payment in cleared funds. Christie's will obtain quotes at the buyer's request. All shipping charges have to be agreed and pre-paid before shipment can be effected. Christie's charges a 10% administrative fee on the shipping quote for managing your shipment. Please be reminded that all shipping quotes are exclusive of any tax and/or duties imposed by government authorities. It is the Buyer's sole responsibility to obtain any required export or import licenses.

Please contact our Post-Sale Services Department +852 2760 1766 or postsaleasia@christies.com for further information.

香港佳士得名酒倉儲與提取

所有在此拍賣的名酒現儲存於佳士得委任的酒窖 - Crown Wine Cellars Limited。

買家如欲直接從儲存設施提貨，請作提前通知以作安排。買家需要簽署由佳士得發出的提貨通知單，以便 Crown Wine Cellars Limited 發放拍賣品。買家支付所有費用後可提出貨品付運的要求，但有關要求必需於付運日期前的兩個工作天提出。買家須負責提取或安排本地送遞及／或運送。所有運費、本地送遞、運輸保險及包裝的費用將由買家負責。所有費用要在運送前預先繳付予佳士得，才會進行付運。所有破損或遺漏瓶數，必須在收到拍賣品後的三天內向佳士得報告。有關安排運送及提取事宜，請聯絡 Crown Wine Cellars Limited 潘先生或林小姐，電話為 +852 2453 3530。

如果已購買的名酒在拍賣日後三十個日曆天內仍未提取，即表示授權 Crown Wine Cellars Limited 儲存該名酒，有關儲存費用會由買家支付，直至該名酒被提取為止。Crown Wine Cellars Limited 將會向買家收取儲存費用並直接向買家發出發票。買家同意佳士得向 Crown Wine Cellars Limited 提供買家之資料，作為發出發票和收取儲存費之用途。

本地普通運單付運費用（價格或有更改）

加急運單及其他不在運輸範圍內區域的運單，請向佳士得名酒部查詢。

送貨 / 收貨			
數量	香港島	九龍及新界	愉景灣，馬灣， 東涌及大嶼山
1-6 瓶	港幣 320	港幣 220	港幣 340
7-12 瓶	港幣 370	港幣 280	港幣 400
13-48 瓶	港幣 480	港幣 380	港幣 500
49-240 瓶	港幣 660	港幣 560	港幣 680

* 241 瓶及以上，請向 Crown Wine Cellars 查詢 +852 2453 3530。

** 送貨收費包括保險費。

送貨時間：星期一至五 上午十一時至下午五時
星期六 正午十二時前

有關儲存設施資料列舉如下：

儲存設施（屯門）

聯絡人：潘先生 (kpun@crownew.com)
林小姐 (angellam@crownew.com)
辦公室電話：+852 2453 3530
地址：新界屯門建豐街 6 號
嘉柏中心 1 期 1 樓

酒窖辦公時間：星期一至五 上午十時正至下午十二時三十分及
下午二時正至下午五時三十分
星期六 上午十時正至下午十二時三十分

海外付運

若付運到其他指定國家，在買方以清算現金全數付清所有欠款後，佳士得可依照買家之要求，代為安排包裝、付運及運輸保險事宜，買家須繳付有關收費。佳士得會根據買家要求，提供報價給予買家。所有付運須於買家同意該運費及繳付後方作安排。佳士得會收取付運報價的 10% 以作行政費用。請注意所有付運報價不包括任何稅項及 / 或出入口稅項。買家須負責取得所有相關的進出口牌照。

詳情請向香港佳士得售後服務部 +852 2760 1766 或 postsaleasia@christies.com 查詢。

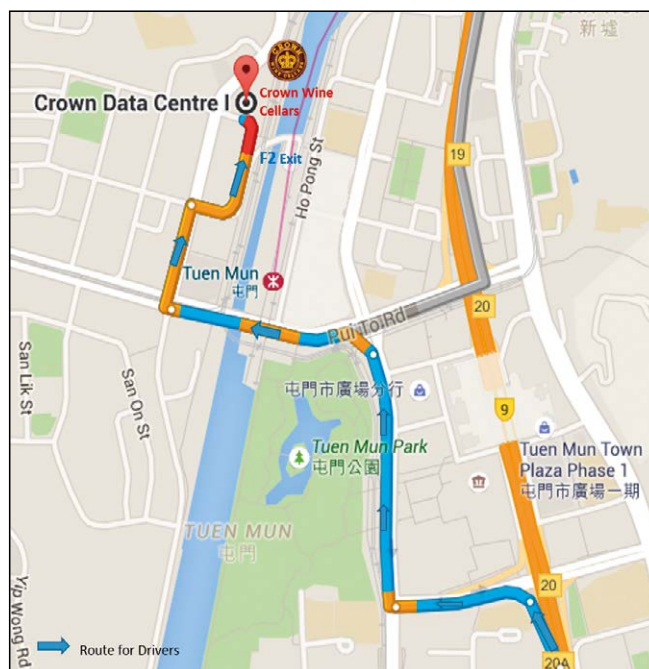



HONG KONG SHORT COURSE 香港短期課程

Art Business Essentials 藝術行業入門

This multi-term intensive programme provides an in-depth understanding of the ecosystem of the international art world for career beginners, career changers and art enthusiasts in the region. It combines the study of art history and theories, art markets and business practices, together with a critical examination of the legal and regulatory issues of the global art trade, offering essential insights to navigate and stay informed about the industry.

佳士得美術學院隆重推出《藝術行業入門》系列課程，為藝術愛好者及有意或已投身藝術行業人士提供認識全球藝術生態系統的機會。本課程以英語講授，編排融合藝術史、行業實務及法律框架、藝術品投資等主題，是探索藝術市場並獲得行業洞見的絕佳學習平台。

Module I : The Business Explained | Autumn 2019

模塊一：行業實務 | 2019年秋季

Module II : The Legal Framework | Spring 2020

模塊二：法律框架 | 2020年春季

Module III : The Creative Asset Class | Autumn 2020

模塊三：投資藝術 | 2020年秋季

Location 地點

Christie's Hong Kong
香港佳士得藝廊

Enquiries 查詢

Yi Gao 高伊
hongkong@christies.edu
+852 2978 6768



christies.edu/Asia

CHRISTIE'S
EDUCATION 佳士得美術學院

FINE & RARE WINES AND SPIRITS

FEATURING AN EXCEPTIONAL PRIVATE
COLLECTION AND A COLLECTION OF
CENTURY OLD MADEIRA

Paddle No.

**SATURDAY 23 NOVEMBER
AT 10.30 AM**

Grand Hall, Hong Kong Convention and Exhibition
Centre, No.1 Expo Drive, Wanchai, Hong Kong

**CODE NAME: DAVID
SALE NUMBER: 17625
LOT NUMBER: 5001-5839**

**Please note that Christie's does not accept payment
from third parties, including agents, and that invoice
details cannot be changed after the sale.**

**BID ONLINE FOR THIS SALE AT
WWW.CHRIStIES.COM**

BIDDING INCREMENTS

Bidding generally starts below the **low estimate** and increases in steps (bid increments) of up to 10 per cent. The auctioneer will decide where the bidding should start and the bid increments. Written bids that do not conform to the increments set below may be lowered to the next bidding-interval.

- HK\$1,000 to HK\$2,000 by HK\$100s
- HK\$2,000 to HK\$3,000 by HK\$200s
- HK\$3,000 to HK\$5,000 by HK\$200, 500, 800
(ie: HK\$4,200, HK\$4,500, HK\$4,800)
- HK\$5,000 to HK\$10,000 by HK\$500s
- HK\$10,000 to HK\$20,000 by HK\$1,000s
- HK\$20,000 to HK\$30,000 by HK\$2,000s
- HK\$30,000 to HK\$50,000 by HK\$2,000, 5,000, 8,000
(ie: HK\$32,000, HK\$35,000, HK\$38,000)
- HK\$50,000 to HK\$100,000 by HK\$5,000s
- HK\$100,000 to HK\$200,000 by HK\$10,000s
- HK\$200,000 to HK\$300,000 by HK\$20,000s
- HK\$300,000 to HK\$500,000 by HK\$20,000, 50,000, 80,000
(ie: HK\$320,000, HK\$350,000, HK\$380,000)
- HK\$500,000 to HK\$1,000,000 by HK\$50,000s
- Above HK\$1,000,000 at auctioneer's discretion

The auctioneer may vary the increments during the course of the auction at his or her own discretion.

1. I request Christie's to bid on the stated **lots** up to the maximum bid I have indicated for each **lot**.
2. I understand that if my bid is successful the amount payable will be the sum of the **hammer price** and the **buyer's premium (together with any taxes chargeable on the hammer price and buyer's premium in accordance with the Conditions of Sale - Buying at Christie's)**. The **buyer's premium** rate shall be an amount equal to 25% of the **hammer price** of each **lot** up to and including HK\$ 2,500,000, 20% on any amount over HK\$ 2,500,000 up to and including HK\$ 30,000,000 and 13.5% of the amount above HK\$ 30,000,000. For wine there is a flat rate of 25% of the **hammer price** of each **lot** sold.
3. I confirm I have read the Conditions of Sale - Buying at Christie's printed in the catalogue which covers the **lot(s)** I register to bid in this form and agree to be bound by the said Condition of Sale.
4. I have read the personal information section of the conditions of sale printed in the sale catalogue and agree to be bound by its terms.
5. I understand that if Christie's receive written bids on a **lot** for identical amounts and at the auction these are the highest bids on the lot, Christie's will sell the **lot** to the bidder whose written bid it received and accepted first.
6. Written bids submitted on "no **reserve**" **lots** will, in the absence of a higher bid, be executed at approximately 50% of the **low estimate** or at the amount of the bid if it is less than 50% of the **low estimate**.

I understand that Christie's written bid service is a free service provided for clients and that, while Christie's will be as careful as it reasonably can be, Christie's will not be liable for any problems with this service or loss or damage arising from circumstances beyond Christie's reasonable control.

Auction Results: +852 2760 1766.

The auctioneer will usually only accept bids for High Value Lots if a deposit has been arranged prior to the day of sale and the High Value Lot pre-registration application has been completed. High Value Lot Deposit Forms should be sent to the Bids Department by email to bidsasia@christies.com. I understand that if I have not completed the High Value Lot pre-registration before sale I will not be permitted to bid for High Value Lots.

If you are not successful in any bid and do not owe any Christie's group company any money, the deposit will be refunded to you by way of wire transfer or such other method as determined by Christie's. Please make sure that you provide your bank details in the High Value Lot Deposit Forms.

Written Bids Form Christie's Hong Kong

Written bids must be received at least 24 hours before the auction begins. Christie's will confirm all bids received by e-mail by return e-mail. If you have not received confirmation within one business day, please resubmit your bid(s) or contact:

Bid Department. Tel: +852 2978 9910 Email: bidsasia@christies.com

Client Number (if applicable) _____

Client Name (please print) _____

Address _____

Contact Number (Mobile) _____

Please verify email address for post-sale communication:

Shipping Quote Required

Shipping address (Same as the above address):

Please tick if you prefer not to receive information about our upcoming sales by e-mail

I HAVE READ AND UNDERSTOOD THIS WRITTEN BID FORM AND THE CONDITIONS OF SALE - BUYING AT CHRISTIE'S

Signature _____ Date _____

If you have not previously bid or consigned with Christie's, please attach copies of the following documents.
Individuals: government-issued photo identification (such as a photo driving licence, national identity card, or passport) and, if not shown on the ID document, proof of current address, for example a utility bill or bank statement. **Corporate clients:** certificate of incorporation, proof of company address, photo ID copy of the authorized bidder, letter of authorization duly signed by the director or the legal representative and, where applicable, chopped with company stamp and official document listing directors and shareholders. **Other business structures such as trusts, offshore companies or partnerships:** please contact the Credit Department at + 852 2978 6870 for advice on the information you should supply. If you are registering to bid on behalf of someone who has not previously bid or consigned with Christie's, please attach identification documents for yourself as well as the party on whose behalf you are bidding, together with a signed letter of authorisation from that party.

New clients, clients who have not made a purchase from any Christie's office within the last 12 months, and those wishing to spend more than on previous occasions will be asked to supply a bank reference and/or a recent bank statement and we may also require a deposit as we deem appropriate as a condition of allowing you to bid. If you are asked to provide a deposit, it may be made by calling at +852 2978 5371. Your bidder registration will not be considered complete until we receive payment of the deposit in full and cleared funds.

PLEASE PRINT CLEARLY

Lot number (in numerical order)	Number of Lots required	Maximum Bid HK\$ (excluding buyer's premium)

CHRISTIE'S 佳士得



佳士得珍罕名釀及烈酒： 呈獻顯赫私人珍藏及馬德拉酒 百年極尚窖藏

二〇一九年 十一月廿三日 星期六
上午十時半

香港灣仔博覽道1號
香港會議展覽中心大會堂

編號名稱：**DAVID**
拍賣編號：**17625**
拍賣品編號：**5001-5839**

佳士得不接受包括代理人在內之第三方付款；付款資料於
拍賣會完結後將不能更改。

參與網絡競投可登入佳士得網站 www.christies.com

競投價遞增幅度

競投一般由低於低價估價開始，通常每次減價之遞增幅度（競投價遞增幅度）最高為10%，拍賣官會自行決定競投開始價位及遞增幅度。書面競投價若與下列之遞增幅度不一致，將被調低至下一個減價金額：

競投價	每次減價之遞增金額
1,000-2,000 港元	100 港元
2,000-3,000 港元	200 港元
3,000-5,000 港元	200, 500, 800 港元 (例 4,200, 4,500, 4,800 港元)
5,000-10,000 港元	500 港元
10,000-20,000 港元	1,000 港元
20,000-30,000 港元	2,000 港元
30,000-50,000 港元	2,000, 5,000, 8,000 港元 (例 32,000, 35,000, 38,000 港元)
50,000-100,000 港元	5,000 港元
100,000-200,000 港元	10,000 港元
200,000-300,000 港元	20,000 港元
300,000-500,000 港元	20,000, 50,000, 80,000 港元 (例 320,000, 350,000, 380,000 港元)
500,000-1,000,000 港元	50,000 港元
1,000,000 港元或以上	拍賣官自行決定

在拍賣時拍賣官酌情更改每次增加之額度。

- 茲請求佳士得就本表格所列的**拍賣品**進行競投，直至本表格所列的最高出價。
- 本人知悉如競投成功，本人應付之購買款項為**成交價及買方酬金（以及所有基於成交價和買方酬金而產生的稅費，及符合業務規定，買方須知）**。買方酬金費率按每件**拍賣品**成交價首港幣2,500,000元之25%，加逾港幣2,500,000元以上至30,000,000元部份之20%；加逾港幣30,000,000元以上之13.5%計算。名酒的**買方酬金**是按每件**拍賣品**成交價之25%。
- 本人確認已閱讀本目錄中所列適用於我通過此表格登記競投**拍賣品**之業務規定，並同意接受該業務規定的管限。
- 本人已細閱載於目錄內業務規定之個人信息條款，並同意遵守該規定。
- 本人理解如佳士得收到多個競投價相等的書面競投，而在拍賣時此等競投價乃該**拍賣品**之最高出價，則該**拍賣品**售給最先送達其書面競投書給本公司之競投人。
- 如果您以書面競投一件“沒有底價”的**拍賣品**，而且沒有其他更高叫價，我們會為您以**低價估價**的50%進行競投；或如果您的投標價低於**低價估價**的50%，則以您的投標價進行競投。

本人亦明白，佳士得的書面競投服務為一項向客戶提供的免費服務，佳士得會合理謹慎進行，佳士得不會就任何在佳士得控制的範圍以外產生的損失或賠償負責。

拍賣結果查詢：**+852 2760 1766**。

拍賣官一般僅接受已於拍賣日前繳付保證金並已完成高價拍賣品預先登記人士之高價拍賣品競投。請將已填妥之高價拍賣品之登記表格電郵 bidsasia@christies.com 至投標部。本人知悉若本人未於拍賣前完成高價拍賣預先登記，本人將不獲准競投高價拍賣品。

若閣下未能成功競投任何**拍賣品**，對佳士得或**佳士得集團**其他公司亦無任何欠款，保證金將以電匯方式或佳士得決定之其他方式退還閣下。請確保閣下已提供有關之銀行資料詳情。

CHRISTIE'S 佳士得

競投牌編號

書面競投表格

香港佳士得

書面競投必須在拍賣開始前至少 24 小時收到。

佳士得公司將以電郵確認收到閣下電郵之書面競投表格。如您在一個工作日內未能收到確認，請重新遞交書面競投表格或聯繫投標部。

電話：+852 2978 9910 電郵：bidsasia@christies.com

客戶編號（若適用）_____

客戶名稱（請用正楷填寫）_____

地址 _____

聯絡電話（手提電話）_____

請確認電郵地址以作售後服務用途：

請提供運費報價

運送地址（ 同上地址相同）：

如閣下不希望透過電郵接收本公司將舉行的拍賣、活動或其他由佳士得集團及其聯營公司提供的服務資料，請於方格內劃上「✓」號。

我本人已細閱並理解本書面競投表格及業務規定，買方須知。

簽名 _____ 日期 _____

如閣下未曾於佳士得競投或託售**拍賣品**，請附上以下文件之副本。**個人**：政府發出附有相片的身分證明文件（如國民身分證或護照），及（如身分證明文件未有顯示現時住址）現時住址證明，如公用事業帳單或銀行月結單。**公司客戶**：公司註冊證書、公司地址證明、被授權競投者附有相片的身分證明文件，由公司董事或法人按公司規定簽署及（若有）蓋有公司章的競投授權書，以及列出所有董事及股東的公司文件。**其他業務結構，如信託機構、離岸公司或合夥公司**：請與信用部聯絡，以諮詢閣下須提供何種資料，電話為 +852 2978 6870。如閣下登記代表未曾於佳士得競投或託售**拍賣品**人士競投，請附上閣下本人的身分證明文件，以及閣下所代表競投人士的身分證明文件，連同該人士簽發的授權書。

新客戶、過去十二個月內未有在佳士得投得**拍賣品**，及本次擬出價金額高於過往之客戶，須提供銀行信用證明及／或近期的銀行月結單，亦或須繳付本公司指定的有關保證金作為允許閣下競投的先決條件。如閣下被要求提供保證金，閣下可致電 +852 2978 5371 安排付款。閣下的競投申請會在我們收到保證金的全額付款後方可作實。

請用正楷填寫清楚

拍賣品編號 (按數字排序)	拍賣品數量	最高競投價(港幣) (買方酬金不計在內)



BIDDER REGISTRATION FORM

Paddle No. _____

We encourage new clients to register at least 48 hours in advance of a sale to allow sufficient time to process the registration.

Please complete and sign this form and send it to us by email registrationasia@christies.com.

A Bidder's Detail

The name and address given above will appear on the invoice for lots purchased with your assigned paddle for this registration. Please check that the details are correct as the invoice cannot be changed after the sale.

Account Name Account No.

Address

..... Post/Zip Code

Phone No.

Please verify email address for post-sale communication

Shipping Quote Required.

Shipping Address (Same as the above address):

.....

B Identity Documents and Financial References

If you are a new client, please provide copies of the following documents. **Individuals:** government-issued photo identification (such as a national identity card or passport) and, if not shown on the ID document, proof of current address, for example a utility bill or bank statement. **Corporate clients:** a certificate of incorporation, proof of company address, photo ID copy of the authorized bidder, letter of authorization duly signed by the director or the legal representative and, where applicable, chopped with company stamp and official document listing directors and shareholders. **Other business structures such as trusts, offshore companies or partnerships:** please contact the Credit Department at +852 2978 6870 for advice on the information you should supply.

If you are registering to bid on behalf of someone who has not previously bid or consigned with Christie's, please attach identification documents for yourself as well as the person on whose behalf you are bidding, together with a signed letter of authorisation from the person.

New clients, clients who have not made a purchase from any Christie's office within the last 12 months, and those wishing to spend more than on previous occasions will be asked to supply a bank reference and/or a recent bank statement and we may also require a deposit as we deem appropriate as a condition of allowing you to bid. Deposit can be paid by using any of the following methods: credit card(s) acceptable to Christie's; wire transfer; cashier order or cheque. We cannot accept payment from third parties and agents. If you are asked to provide a deposit, it may be made by calling at +852 2978 5371. Your bidder registration will not be considered complete until we receive payment of the deposit in full and cleared funds.

To apply for a high value lot ("HVL") paddle, you will need to pay a HVL deposit, which we will calculate for you. Generally it will be the higher of: (i) HK\$ 1,600,000 or (ii) 20 % of the aggregate low estimates of the HVLs you intend to bid on; or (iii) such other amount as we may determine from time to time. The HVL registration procedure applies even if you have already registered to bid in our sales on other lots. We reserve the right to change our HVL registration procedure and requirements from time to time without notice.

C Sale Registration

- | | |
|--|---|
| <input type="checkbox"/> 17625 Fine & Rare Wines and Spirits Featuring an Exceptional Private Collection and a Collection of Century Old Madeira | <input type="checkbox"/> 17208 Chinese Contemporary Ink |
| <input type="checkbox"/> 17474 Handbags & Accessories | <input type="checkbox"/> 17209 Fine Chinese Classical Paintings and Calligraphy |
| <input type="checkbox"/> 17478 Hong Kong Magnificent Jewels * | <input type="checkbox"/> 17210 Fine Chinese Modern Paintings * |
| <input type="checkbox"/> 17481 The Masterpiece Auction *
Important Watches including an Important Private Asian Collection Part 1 | <input type="checkbox"/> 17742 The Chang Wei-Hwa Collection of Archaic Jades, Part I:
Neolithic Period |
| <input type="checkbox"/> 15618 20th Century & Contemporary Art (Evening Sale) * | <input type="checkbox"/> 19171 On The Studio Desk * |
| <input type="checkbox"/> 18773 HI-LITE * | <input type="checkbox"/> 17741 An Important Collection Of Chinese Ceramics
From A Private Collector |
| <input type="checkbox"/> 15619 20th Century & Contemporary Art (Morning Session) | <input type="checkbox"/> 19172 A Dream Realised: Kangxi's Ultimate <i>Falangcai</i> bowl * |
| <input type="checkbox"/> 15620 20th Century & Contemporary Art (Afternoon Session) | <input type="checkbox"/> 16696 Important Chinese Ceramics and Works of Art * |

* If you intend to bid on: (i) any lot in the 20th Century & Contemporary Art Evening Sale; or (ii) a lot the low estimate of which is HK\$ 8 million or above, i.e. a high value lot ("HVL"), please tick the box below.

I wish to apply for a HVL paddle.

If you intend to bid on the "Five Nudes" by Sanyu, please tick the box below.

I wish to apply for a HVL paddle designated for the "Five Nudes".

Please indicate the bidding level you require:

- | | | |
|--|---|--|
| <input type="checkbox"/> HK \$ 0 - 500,000 | <input type="checkbox"/> HK \$ 500,001 - 2,000,000 | <input type="checkbox"/> HK \$ 2,000,001 - 4,000,000 |
| <input type="checkbox"/> HK \$ 4,000,001 - 8,000,000 | <input type="checkbox"/> HK \$ 8,000,001 - 20,000,000 | <input type="checkbox"/> HK \$ 20,000,000 + |

D Declarations

- I have read the "Conditions of Sale - Buying at Christie's" and "Important Notices and Explanation of Cataloguing Practice" printed in the sale catalogue, as well as the "No Third Party Payment Notice" and agree to be bound by them.
- I have read the personal information section of the conditions of sale printed in the sale catalogue and agree to be bound by its terms.
- I understand that if I have not completed the high value lot pre-registration before the auction Christie's may refuse my bid for high value lots.
- If you are not successful in any bid and do not owe any Christie's group company any money, the deposit will be refunded to you by way of wire transfer or such other method as determined by Christie's. please make sure that you provide your bank details to us.

Please tick if you are a new client and would like to receive information about sales, events and other services offered by the Christie's group and its affiliates by e-mail. You can opt-out of receiving this information at any time.

Name Signature Date

建議新客戶於拍賣舉行前至少 48 小時辦理登記，以便有充足時間處理登記手續。

請填妥並簽署本表格然後電郵至 registrationasia@christies.com。

A 投標者資料

客戶名稱及地址會列印在附有是次登記之競投牌編號的發票上；付款資料於拍賣會完結後將不能更改，請確定以上資料確實無誤

客戶名稱 客戶編號

客戶地址

..... 郵區編號

電話號碼

請確認電郵地址以作售後服務用途

請提供運費報價。

運送地址 (同上述地址相同) :

B 身份證明文件及財務證明

如閣下為新客戶，請提供以下文件之副本。**個人**：政府發出附有相片之身份證明文件（如國民身份證或護照），及（如身份證明文件未有顯示現時住址）現時住址證明，如公事事業帳單或銀行月結單。**公司客戶**：公司註冊證書、公司地址證明、被授權競投者附有相片之身份證明文件，由公司董事或法人按公司規定簽署及（若有）蓋有公司章的競投授權書，以及列出所有董事及股東的公司文件。**其他業務結構，如信託機構、離岸公司或合夥公司**：請與信用部聯絡，以諮詢閣下須提供何種資料，電話為 +852 2978 6870。

如閣下登記代表未曾於佳士得競投或託售拍賣品人士競投，請附上閣下本人的身份證明文件，以及閣下所代表競投人士的身份證明文件，連同該人士簽署的授權書。

新客戶、過去十二個月內未有在佳士得投得拍賣品，及本次擬出價金額高於過往之客戶，須提供銀行信用證明及／或近期的銀行月結單，亦或須繳付本公司指定的有關保證金作為允許閣下競投的先決條件。閣下可以佳士得接受之信用卡、電匯、本票或支票繳付保證金。請注意佳士得概不接受第三方或代理人代付之款項。如閣下被要求提供保證金，閣下可致電 +852 2978 5371 安排付款。閣下的競投申請會在我們收到保證金的全額付款後方可作實。

如需申請高額拍品競投號碼牌，閣下需繳付適用於高額拍品的保證金——一般為 (i) 港幣 1,600,000 元；或 (ii) 閣下擬競投的全部拍賣品低估價總額之 20%；或 (iii) 其他我們不時設定的金額（以較高者為準）。即使閣下已於佳士得其他拍賣登記，閣下仍需為高額拍品按高額拍品登記程序進行登記。佳士得保留不時更改高額拍品登記程序及要求的權利而不作另行通知。

C 拍賣項目登記

- | | |
|---|--|
| <input type="checkbox"/> 17625 佳士得珍罕名釀及烈酒：呈獻顯赫私人珍藏及馬德拉酒百年極尚窖藏 | <input type="checkbox"/> 17208 中國當代水墨 |
| <input type="checkbox"/> 17474 典雅傳承：手袋及配件 | <input type="checkbox"/> 17209 中國古代書畫 |
| <input type="checkbox"/> 17478 瑰麗珠寶及翡翠首飾* | <input type="checkbox"/> 17210 中國近現代畫* |
| <input type="checkbox"/> 17481 名匠巨鑄*
精緻名錶及亞洲重要私人收藏（第一部份） | <input type="checkbox"/> 17742 雲中玉筵——重要亞洲私人古玉珍藏：新石器時代篇 |
| <input type="checkbox"/> 15618 二十世紀及當代藝術（晚間拍賣）* | <input type="checkbox"/> 19171 斗室案上* |
| <input type="checkbox"/> 18773 HI-LITE* | <input type="checkbox"/> 17741 私人珍藏重要中國瓷器 |
| <input type="checkbox"/> 15619 二十世紀及當代藝術（上午拍賣） | <input type="checkbox"/> 19172 圓夢——康熙琺瑯彩千葉蓮盤* |
| <input type="checkbox"/> 15620 二十世紀及當代藝術（下午拍賣） | <input type="checkbox"/> 16696 重要中國瓷器及工藝精品* |

*如閣下有意競投 (i) 佳士得二十世紀及當代藝術晚間拍賣之任何拍賣品；或 (ii) 其他類別拍賣低估價為港幣 8,000,000 元或以上的拍賣品，即高額拍品，請於以下方格劃上「✓」號。

本人有意登記高額拍品競投牌。

如閣下有意競投常玉《五裸女》，請於以下方格劃上「✓」號。

本人有意登記有關《五裸女》的高額拍品競投牌。

請提供閣下之競投總額：

- | | | |
|---|--|---|
| <input type="checkbox"/> 港幣 0 - 500,000 | <input type="checkbox"/> 港幣 500,001 - 2,000,000 | <input type="checkbox"/> 港幣 2,000,001 - 4,000,000 |
| <input type="checkbox"/> 港幣 4,000,001 - 8,000,000 | <input type="checkbox"/> 港幣 8,000,001 - 20,000,000 | <input type="checkbox"/> 港幣 20,000,000 + |

D 聲明

- 本人已細閱載於目錄內之業務規定、買家須知、重要通告及目錄編列方法之說明及不接受第三方付款通告，並同意遵守所有規定。
 - 本人已細閱載於目錄內業務規定之個人信息條款，並同意遵守該規定。
 - 本人知悉若本人未於拍賣前完成高額拍賣預先登記，佳士得將有權不接受任何高額拍品之競投。
 - 若閣下未能成功競投任何拍賣品，對佳士得或佳士得公司集團亦無任何欠款，保證金將以電匯方式或佳士得決定之其他方式退還閣下。請確保閣下已提供有關之銀行資料詳情。
- 如閣下為新客戶並希望透過電郵接收本公司將舉行的拍賣、活動或其他由佳士得集團及其聯營公司提供的服務資料，請於方格內劃上「✓」號。閣下可隨時選擇拒收此訊息。

姓名 簽署 日期



CHRISTIE'S

CHRISTIE'S INTERNATIONAL PLC

François Pinault, Chairman
Guillaume Cerutti, Chief Executive Officer
Stephen Brooks, Deputy Chief Executive Officer
Jussi Pylkkänen, Global President
François Curriel, Chairman, Europe
Jean-François Palus
Stéphanie Renault
Héloïse Temple-Boyer
Sophie Carter, Company Secretary

INTERNATIONAL CHAIRMEN

Stephen Lash, Chairman Emeritus, Americas
The Earl of Snowdon, Honorary Chairman, EMEA
Charles Cator, Deputy Chairman, Christie's Int.
Xin Li-Cohen, Deputy Chairman, Christie's Int.

CHRISTIE'S ASIA PACIFIC

Francis Belin, President

CHAIRMAN'S OFFICE

Jonathan Stone, Deputy Chairman
Pola Antebi, Deputy Chairman
Eric Chang, Deputy Chairman
Charmie Hamami, Deputy Chairman
Ben Kong, Deputy Chairman
Evelyn Lin, Deputy Chairman
Ada Ong, Deputy Chairman
Vickie Sek, Deputy Chairman
Chi Fan Tsang, Deputy Chairman

CHRISTIE'S ADVISORY COUNCIL, ASIA PACIFIC

Jinqing Cai, Chairman
Pierre Chen, Raymond Ch'ien, William Fung,
Qiong Er Jiang, Handel Lee, Anthony Lin,
Pan Gong Kai, Dee Poon, Mimi Tang,
Patrick Thomas, Wang Wei, Douglas Woo

SENIOR VICE PRESIDENTS

Karen Au Yeung, Lavina Chan, Elaine Holt,
Kitty Mak, Audrey Shum, Bo Tan,
Katsura Yamaguchi

VICE PRESIDENTS

Alexandre Bigler, Carmen Shek Cerne, Janet Chang,
Liang-Lin Chen, Blanca Cheng, Fung Chiang,
Betsy Chow, Jennie Chu, Isabel Coutier,
Emily Fisher, Dexter How, Julia Hu,
Seiji Inami, Marcello Kwan, Elaine Kwok,
Stephenie Leung, Ruben Lien, Gabrielle Mak,
Sara Mao, Lillian Ng, Jasmin Ngai,
Jessie Or, Terence Poon, Sonal Singh,
Ronan Sulich, Winsy Tsang, Nicole Wright,
Alan Yip, Kim Yu, Dina Zhang,
Grace Zhuang

ASSOCIATE VICE PRESIDENTS

Lee Bingle, Selina Chan, Winifred Chan,
Kelly Chang, Lesley Chen, Amy Cheng,
Joanne Cheng, Isaac Choi, Terry Choi,
Yanie Choi, Dai Dai, Helen Fung,
Georgina Hilton, Gigi Ho, Phylbie Ho,
Yunah Jung, Masahiko Kuze, Annie Lee,
Joyce Lee, Kevyn Leung, Nelly Li,
Rachel Li, Caroline Liang, Louis Lin,
Georgina Liu, Vicky Liu, Yu-Shan Lu,
Tony Ng, Benson Or, Felix Pei,
Zhongwei Qin, Sherese Tong, CC Wang,
Mandy Wang, Aaron Wong, Michael Xie,
Maxwell Yao, Harriet Yu, Mia Zhang,
Michelle Zhang, Terry Zhou

01/09/2019

HONG KONG AUCTION CALENDAR

FINE & RARE WINES AND SPIRITS FEATURING AN EXCEPTIONAL PRIVATE COLLECTION AND A COLLECTION OF CENTURY OLD MADEIRA

Sale number: 17625
**SATURDAY 23 NOVEMBER
10.30 AM**

THE MASTERPIECE AUCTION

Sale number: 17481
**SATURDAY 23 NOVEMBER
5.30 PM**
Viewing: 22-23 November

20TH CENTURY & CONTEMPORARY ART (EVENING SALE)

Sale number: 15618
**SATURDAY 23 NOVEMBER
5.30 PM**
Viewing: 22-23 November

HI-LITE

Sale number: 18773
**SATURDAY 23 NOVEMBER
5.30 PM**
Viewing: 22-23 November

20TH CENTURY & CONTEMPORARY ART (MORNING SESSION)

Sale number: 15619
**SUNDAY 24 NOVEMBER
10.00 AM**
Viewing: 22-23 November

20TH CENTURY & CONTEMPORARY ART (AFTERNOON SESSION)

Sale number: 15620
**SUNDAY 24 NOVEMBER
1.30 PM**
Viewing: 22-23 November

CHINESE CONTEMPORARY INK

Sale number: 17208
**MONDAY 25 NOVEMBER
11.00 AM**
Viewing: 22-24 November

FINE CHINESE CLASSICAL PAINTINGS AND CALLIGRAPHY

Sale number: 17209
**MONDAY 25 NOVEMBER
2.30 PM**
Viewing: 22-25 November

HANDBAGS & ACCESSORIES

Sale number: 17474
**MONDAY 25 NOVEMBER
3.00 PM**
Viewing: 22-25 November

FINE CHINESE MODERN PAINTINGS

Sale number: 17210
**TUESDAY 26 NOVEMBER
2.00 PM**
Viewing: 22-25 November

HONG KONG MAGNIFICENT JEWELS

Sale number: 17478
**TUESDAY 26 NOVEMBER
1.00 PM**
Viewing: 22-26 November

THE CHANG WEI-HWA COLLECTION OF ARCHAIC JADES, PART I - NEOLITHIC PERIOD

Sale number: 17742
**WEDNESDAY 27 NOVEMBER
10.30 AM**
Viewing: 22-26 November

IMPORTANT WATCHES INCLUDING AN IMPORTANT PRIVATE ASIAN COLLECTION PART 1

Sale number: 17481
**WEDNESDAY 27 NOVEMBER
11.00 AM**
Viewing: 22-26 November

ON THE STUDIO DESK

Sale number: 19171
**WEDNESDAY 27 NOVEMBER
11.30 AM**
Viewing: 22-26 November

AN IMPORTANT COLLECTION OF CHINESE CERAMICS FROM A PRIVATE COLLECTOR

Sale number: 17741
**WEDNESDAY 27 NOVEMBER
2.30 PM**
Viewing: 22-26 November

A DREAM REALISED: KANGXI'S ULTIMATE FALANGCAI BOWL

Sale number: 19172
**WEDNESDAY 27 NOVEMBER
2.50 PM**
Viewing: 22-26 November

IMPORTANT CHINESE CERAMICS AND WORKS OF ART

Sale number: 16696
**WEDNESDAY 27 NOVEMBER
2.50 PM**
Viewing: 22-26 November



CHRISTIE'S 佳士得

22ND FLOOR ALEXANDRA HOUSE 18 CHATER ROAD CENTRAL HONG KONG
香港 中環 遮打道18號 歷山大廈22樓